

The image shows the cover of the Leica 3D Disto User Manual. The background is a photograph of a large, industrial-style building with arched windows. In the foreground, a Leica 3D Disto laser distance measurer is shown in its red and black carrying case. The device's screen displays a 3D wireframe model of a spiral staircase. The model is annotated with technical data: a radius of 4.9m, a diameter of 9.8m, and a height of 6.712m. A solid red horizontal bar is positioned at the top of the page, partially overlapping the image.

Leica 3D Disto User Manual

Version 3.0
English

- when it has to be **right**

Leica
Geosystems

Introduction

Purchase



Congratulations on the purchase of a Leica 3D Disto.

This manual contains important safety directions as well as instructions for setting up the product and operating it. Refer to "12 Safety Directions" for further information.

Read through the *User Manual* carefully before you switch on the product.





Product identification

The serial number of your product is indicated on the data label, refer to "12.8 FCC Statement, Applicable in U.S.". Enter the serial number in your manual and always refer to this information when you contact your authorised dealer or to register in the Leica myWorld portal.

Serial number: _____

Symbols

The symbols used in this manual have the following meanings:

Type	Description
 Danger	Indicates an imminently hazardous situation which, if not avoided, will result in death or serious injury.
 Warning	Indicates a potentially hazardous situation or an unintended use which, if not avoided, could result in death or serious injury.
 Caution	Indicates a potentially hazardous situation or an unintended use which, if not avoided, may result in minor or moderate injury and/or appreciable material, financial and environmental damage.
	Important paragraphs which must be adhered to in practice as they enable the product to be used in a technically correct and efficient manner.

Trademarks

- Windows is a registered trademark of Microsoft Corporation. All other trademarks are the property of their respective owners.

Table of Contents

In this manual	Chapter	Page
	1 How to Use this Manual	10
	2 Technical Terms and Abbreviations	14
	3 Description of the System	27
	3.1 General 3D Disto System Information	27
	3.2 Container Contents	28
	3.3 Instrument Components	30
	3.3.1 3D Disto	30
	3.3.2 Control Unit	34
	3.3.3 RM100 Remote Control	35
	3.4 Power Supply	36
	3.4.1 3D Disto	36
	3.4.2 Control Unit	37
	3.4.3 RM100 Remote Control	39
	3.5 Software Concept	40

4	User Interface	47
<hr/>		
4.1	Control Unit	47
	4.1.1 Screen	48
	4.1.2 Main Operation Bar	51
	4.1.3 Toolbar	52
	4.1.4 Icons & Symbols	53
4.2	RM100 Remote Control	57
5	Instrument Setup	58
<hr/>		
5.1	Start-up Procedure	58
5.2	Assistant	65
5.3	Device Configuration and Menu Settings	67
5.4	Data Management	71
	5.4.1 General	71
	5.4.2 File Manager	73
	5.4.3 Photo and Secure Points Administration	74
	5.4.4 Data Transfer	76
	5.4.5 Exported files	82
5.5	Calculator	83

6	Operation	85
6.1	Measurements	85
6.2	Viewfinder	86
6.3	Measurement Workflow	91
6.4	Touch Screen in Sketch Area	97
6.5	Addition and Subtraction	99
6.6	Area & Volume Calculations	102
6.6.1	Horizontal Areas/Volumes	103
6.6.2	Tilted Areas	105

7	Software Applications	106
7.1	Overview	106
7.2	Tool Kit	107
7.2.1	Comfort Plumbing	108
7.2.2	Comfort Targeting	110
7.2.3	Comfort Level	112
7.2.4	Metre Mark	114
7.2.5	Height Tracking	116
7.2.6	Parallel Line	118
7.3	Location	120
7.4	Room Scan	126
7.4.1	Manual Measurement	128
7.4.2	Unfold Mode	130
7.4.3	CAD tools	132
7.4.4	Automated Scans	149
7.5	Projector	159
7.5.1	Workflow	160
7.5.2	Targeting and Layout with RM100 Remote Control	167
8	Error Messages	168

9	Check & Adjust	171
9.1	Overview	171
9.2	Crosshairs Offset	173
9.3	V-Index Error	175
9.4	Tilt Sensor Calibration	177
9.5	Reset to Factory Settings	179
10	Instrument Protection (Theft Protection)	180
11	Care and Transport	182
11.1	Transport	182
11.2	Storage	183
11.3	Cleaning and Drying	184
12	Safety Directions	185
12.1	General	185
12.2	Intended Use	186
12.3	Limits of Use	188
12.4	Responsibilities	189
12.5	Hazards of Use	190
12.6	Laser Classification	194
12.7	Electromagnetic Compatibility EMC	196
12.8	FCC Statement, Applicable in U.S.	199
12.9	Conformity to National Regulations	203

13 Technical Data	205
14 International Limited Warranty, Software License Agreement	210
Index	213

1

How to Use this Manual



It is recommended to set up the instrument while reading through this manual.

Index

The index is at the back of the manual.





Keys, fields and options on the screens which are considered self-explanatory are not explained.

Validity of this manual

This manual applies to the 3D Disto instruments and software application.

Available
documentation

Name	Description/Format		
3D Disto User Manual	All instructions required in order to operate the instrument at a basic level are contained in this User Manual. Provides an overview of the instrument together with technical data and safety directions.	-	✓
3D Disto Quick Start	Intended as a quick reference field guide.	✓	✓
Safety Manual	Provides important safety instructions for use of 3D Disto.	✓	✓

Refer to the following resources for all 3D Disto documentation/software:

- Leica 3D Disto Data CD
- <https://myworld.leica-geosystems.com>



myWorld@Leica Geosystems (<https://myworld.leica-geosystems.com>) offers a wide range of services, information and training material.

In myWorld, you are able to access all relevant services at your convenience, 24 hours a day, 7 days a week. This increases your efficiency and keeps you and your equipment updated with the latest information from Leica Geosystems.

myWorld

- ↓ myProducts
- ↓ myService
- ↓ mySupport
- ↓ myTraining
- ↓ myDownloads

myWorld



myProducts

Simply add all Leica Geosystems products that you and your company own and explore your world of Leica Geosystems. View detailed information on your products, buy additional options or Customer Care Packages (CCP), update your products with the latest software and keep up-to-date with the latest documentation.



myService

View the service history of your products in Leica Geosystems Service Centers and detailed information on the services performed on your products. For your products that are currently in Leica Geosystems Service Centers view the current service status and the expected end date of service.



mySupport

Create new support requests for your products that will be answered by your local Leica Geosystems Support Team. View the complete history of your Support and view detailed information on each request in case you want to refer to previous support requests.



myTraining

Enhance your product knowledge with the Leica Geosystems Campus - Information, Knowledge, Training. Study the latest online training material or download training material on your products. Keep up-to-date with the latest news on your products and register for Seminars or Courses in your country.



myDownloads

Simply download the latest documentation and software to keep yourself and your products up-to-date. You can access downloads of Software, Manuals, Tools, Training Material and News for Leica Geosystems Products.

Your Contact

Leica Geosystems AG
Herrlich-1000-Strasse
CH-8435 Heerbrugg
Tel. 071 727 31 31

Latest News

October 14, 2010
Gottthardt: Longest Rail Tunnel cut-through
with Leica Geosystems precision
→ [more](#)

October 6, 2010
Leica Geosystems announces Leica Viva
Be/Over "Turn-on & Measure" GRSS
solution
→ [more](#)

October 6, 2010
Leica Viva GS12 receiver for combined
GRSS/TPS one-person surveying
→ [more](#)

→ [Read all news](#)

Service	Description
myProducts	Simply add all Leica Geosystems products that you and your company own. View detailed information on your products, buy additional options, update your products with the latest software and keep up-to-date with the latest documentation.
mySupport	Create new support requests for your products that will be answered by your local Leica Geosystems Support Team. See the complete history of your support cases and view detailed information on each request if you want to refer to previous support requests.
myTraining	Enhance your product knowledge with the Leica Geosystems Campus - Information, Knowledge, Training. Study the latest online training material or download training material on your products. Keep up-to-date with the latest news on your products and register for seminars or courses in your country.

2 Technical Terms and Abbreviations

Line of sight

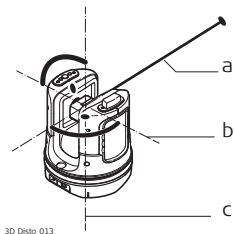

- a) Line of sight
- b) Tilting axis, horizontal rotation axis of the instrument
- c) Standing axis, vertical rotation axis of the instrument



Line of sight, laser beam and crosshairs must be congruent. Refer to "9 Check & Adjust" for more information.

Horizontal angle

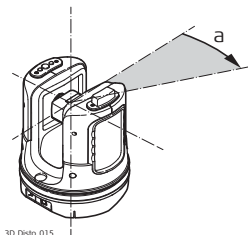

- a) Horizontal angle: [°] or [gon]

Vertical angle

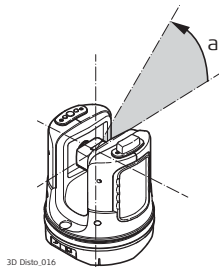

Setting: Horizon = 0

a) Vertical angle: [°], [gon], [1:n] or [%]

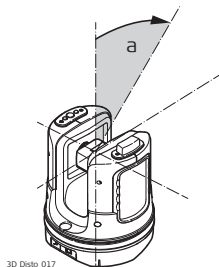

Setting: Horizon = 90°/100gon

a) Vertical angle: [°] or [gon]

Distances

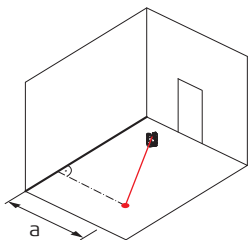

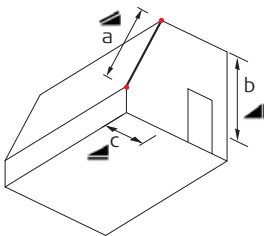

3D Disto_018

a) Perpendicular distance



3D Disto_019

- a) Tie distance 
b) Vertical distance  = height difference
c) Horizontal distance 

Areas

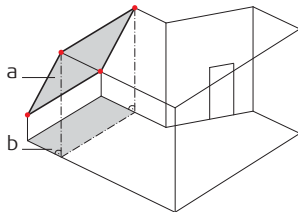

3D Disto_020

- a) Tilted area, as measured
- b) Horizontal area, calculated by 3D Disto

Plumb up and horizon

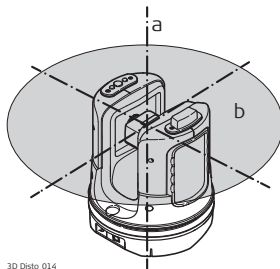

3D Disto_014

- a) **Plumb up:**
Point on the plumb line above the observer.
- b) **Horizon:**
Plane/Line 90° to the plumb line.

References

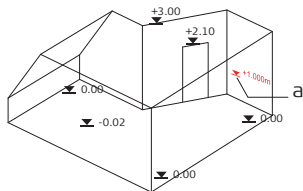

3D Disto_021

- a) **Reference height:**
A level that all heights refer to.

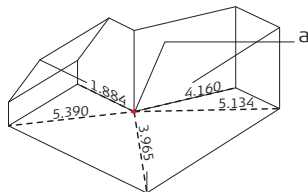

3D Disto_022

- a) **Reference point:**
A point that all dimensions and positions refer to.

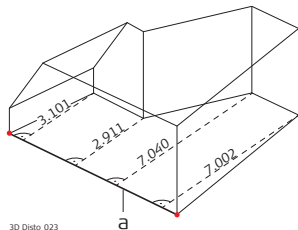

- a) **Reference axis/line:**
A line that all dimensions refer to.

Tilt sensor

The tilt sensor guarantees correct results even if the 3D Disto is not set up horizontally.

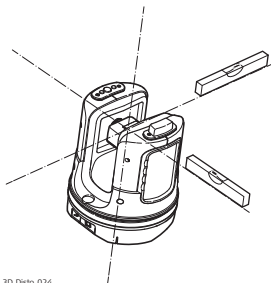

3D Disto_024

Tilt sensor off = disabled
All measurement results relate to the **tilted axis and horizon** of the 3D Disto.

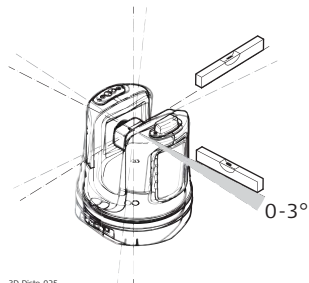

3D Disto_025

Tilt sensor on = enabled
All measurement results relate to the **horizontal axis and horizon** if the 3D Disto is set up between 0° and 3°.

Viewfinder and crosshairs

- **Viewfinder** is an integrated camera which shows the target on the Control Unit display.
- **Crosshairs** is an aiming guide displayed in the Viewfinder on the Control Unit.

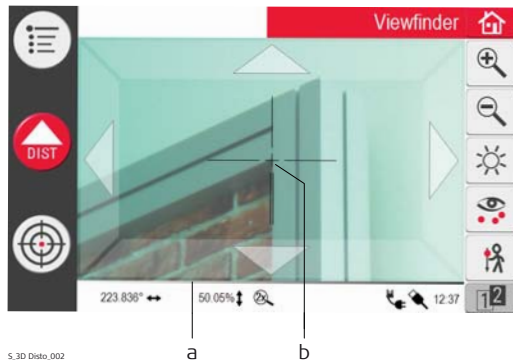

5_3D Disto_002

- a) Viewfinder
b) Crosshairs

Secure Points

Secure Points **link measurements to a coordinate system**. These reference points allow changing the 3D Disto's location or continuing measurements at a later time, so that all measurements fit together perfectly.

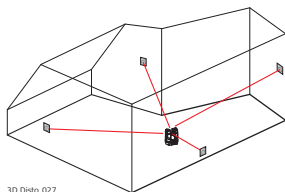
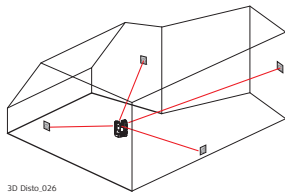

1. Name and place three to five self-adhesive target marks on walls, ceiling or floor around your working area.
2. Measure these target marks and save them as Secure Points.
3. Move the 3D Disto or set it up "anywhere" at a later time.
4. Measure the Secure Points again. 3D Disto relocates itself and measurements can be continued.



Refer to "7.3 Location" for more information.

Coordinates

Coordinates describe the position of a point in two- and three-dimensional space.

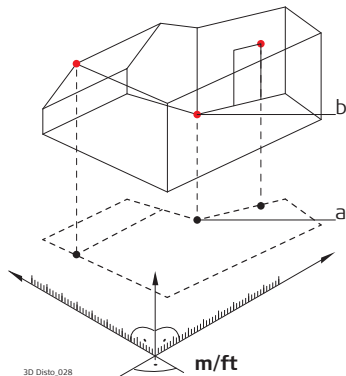

3D Disto.028

- a) Two-dimensional coordinates
- b) Three-dimensional coordinates

Measure

Measurement results can be transferred to a connected PC or USB stick for post-processing.

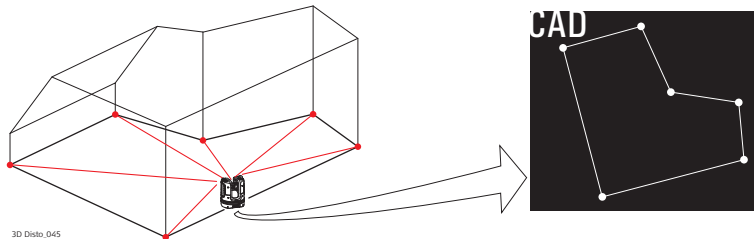

Layout or projection

Design data in DXF and common table formats can be imported and used to lay out the corresponding points or grids.

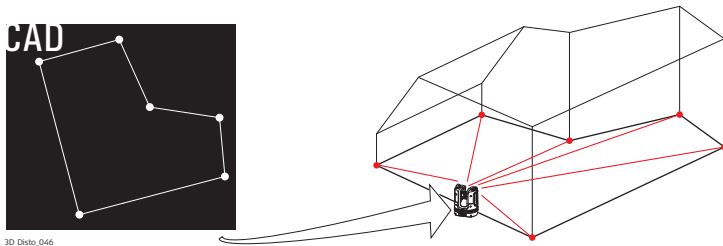

Laser distance metre (LDM)

The laser distance metre (LDM) determines distances using a visible red laser beam.

Calibration

Calibration is a workflow to check and adjust the accuracy of the instrument. Refer to "9 Check & Adjust" for more information.

Ruler for offset points

The ruler for offset points is an accessory to measure inaccessible or hidden points.

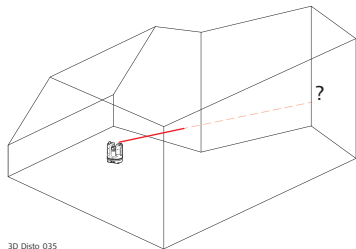

3D Disto_035

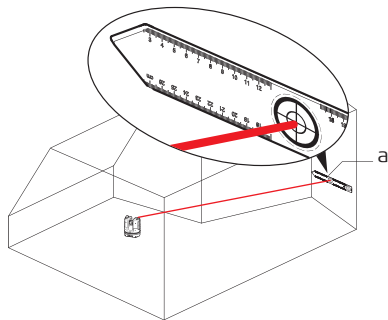

a) Ruler for offset points

3 Description of the System

3.1 General 3D Disto System Information

General information

Leica Geosystems' 3D Disto is a three-dimensional measuring and projection system to measure points in a room from one setup position and that generates 3D data – ready to use or for post-processing.

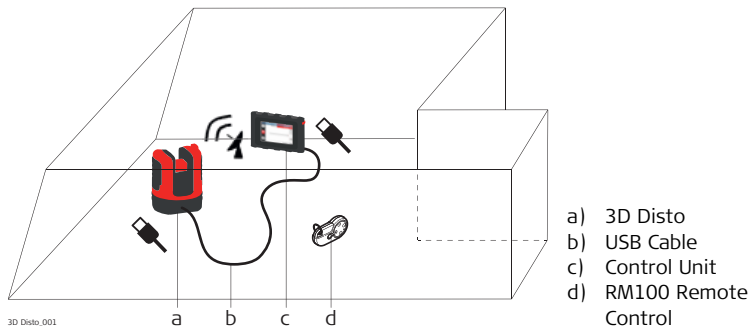

3D Disto is operated by the Control Unit. Certain functions can also be executed using the RM100 Remote Control.

3.2

Container Contents

Container contents, part 1 of 2

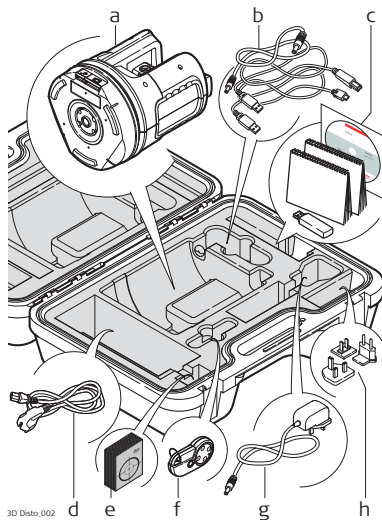

- a) 3D Disto with built-in SD WLAN card
- b) USB connection cable 3D Disto to the Control Unit
Power cable 3D Disto to the Control Unit
Micro-USB cable for PC
- c) Data CD
Safety Instructions Manual, 3D Disto Quick Start, CE & Producer Certificate, USB Stick
- d) Four country-specific cables for 3D Disto power supply
- e) Target marks, self-adhesive, 50 units in one bag
- f) RM100 Remote Control
- g) Control Unit power supply
- h) Country-specific adapter plug-ins for Control Unit power supply

Container contents, part 2 of 2

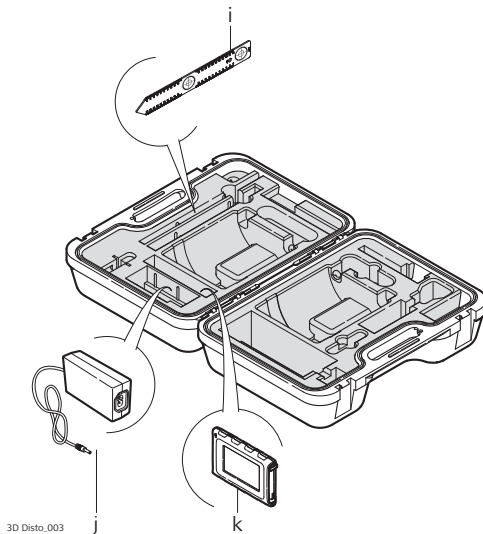

- i) Ruler for offset points
- j) 3D Disto power supply
- k) Control Unit with stylus, tripod clamp and hand strap

3.3

Instrument Components

3.3.1

3D Disto

Instrument components, motor-driven part

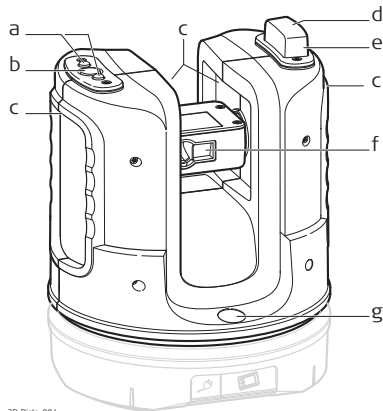

3D Disto_004

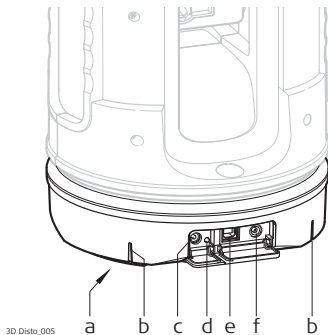

- a) LEDs for 3D Disto status
- b) ON/OFF button
- c) Grips to hold the instrument
- d) Infrared (IR) interface
- e) WLAN interface
- f) Laser distance metre with Viewfinder
- g) Circular bubble

Instrument component, battery socket



- a) Tripod thread 5/8"
- b) 90° marking
- c) Power supply connector for 3D Disto
- d) LED for battery status
- e) Data cable connector
- f) Power supply connector to Control Unit

Description of buttons and LEDs

Button/LEDs	Description
<p data-bbox="368 218 554 244">ON/OFF button</p> 	<p data-bbox="605 218 1370 311">Button to turn instrument ON or OFF. Instrument turns OFF after 15 minutes if not connected to the Control Unit or PC.</p>
<p data-bbox="368 396 583 453">LEDs for 3D Disto status</p> 	<ul data-bbox="605 396 1370 767" style="list-style-type: none"> • Green and orange LEDs lights up continuously: 3D Disto is booting. • Orange LED flashes: Self-levelling procedure is running or tilt > 3°. • Green LED flashes: 3D Disto is ready for measurement. Tilt sensor is on. • Orange LED lights up continuously: An error occurred. Refer to "8 Error Messages" for more information. • Green and orange LEDs light up continuously: Press the ON Button to reset the instrument. <p data-bbox="605 785 1030 811">For experts only: Tilt sensor off</p> <ul data-bbox="605 821 1249 847" style="list-style-type: none"> • Green LED flashes once; orange LED three times.

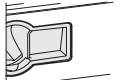
Button/LEDs	Description
<p data-bbox="368 161 554 218">LED for battery status</p> 	<p data-bbox="605 161 1209 187">If instrument is on and connected to the charger:</p> <ul data-bbox="605 192 1260 332" style="list-style-type: none"><li data-bbox="605 192 1260 218">• Green LED flashes 1x: Battery is charged to 25 %.<li data-bbox="605 223 1260 249">• Green LED flashes 2x: Battery is charged to 50 %.<li data-bbox="605 254 1260 280">• Green LED flashes 3x: Battery is charged to 75 %.<li data-bbox="605 285 1260 311">• Green LED is on: Battery is fully charged.
<p data-bbox="368 363 496 389">LDM Laser</p> 	<ul data-bbox="605 363 1348 524" style="list-style-type: none"><li data-bbox="605 363 1348 389">• OFF: Viewfinder is OFF or 3D Disto targets automatically.<li data-bbox="605 394 1348 451">• ON: Viewfinder is ON; or user is targeting by Remote Control.<li data-bbox="605 456 1348 524">• Flashing: to indicate the precise position of a projected point.

3.3.2

Control Unit

Control Unit components

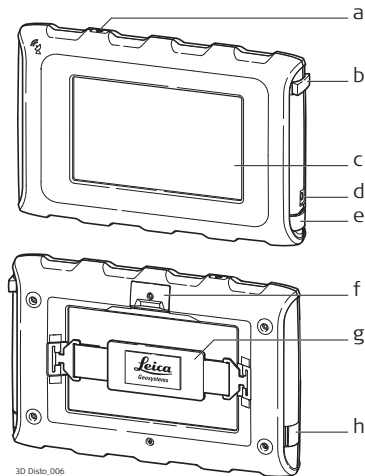

- a) ON/OFF button
- b) Stylus
- c) Display, 4.8" touch screen
- d) Power supply connector
- e) USB Port, type A
- f) Tripod clamp, extendable
- g) Hand strap
- h) Micro-USB port, type Micro-B

3.3.3

RM100 Remote Control

Remote Control components

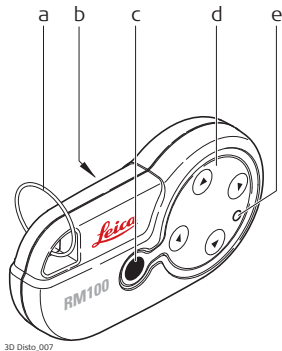

3D Disto_007

- a) Key ring
- b) Battery compartment
- c) Dist button
- d) Navigation buttons:
Up/down/right/left
- e) Control LED

3.4

3.4.1

3D Disto power supply

Power Supply

3D Disto

Power for the instrument can be supplied either internally or externally:

- **Internal:** by battery socket, with non-removable Li-Ion batteries, 14.4 V, 63 Wh.
- **External:**
Power supply for 3D Disto connected by cable with country-specific plugs for worldwide use. Input: 100 - 240 V AC, 50/60 Hz. Output: 24 V DC, 2.5 A. Length 1.80 m.

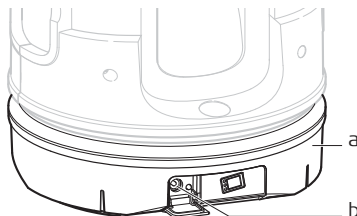

3D Disto_008

- a) Battery socket
- b) Power supply connector



Only Leica Geosystems authorised service workshops are entitled to replace the battery socket.

3.4.2

Control Unit

Control Unit power supply

Power for the Control Unit can be supplied either internally or externally:

- **Internal:** non-removable Lithium polymer battery, 2500 mAh, 3.7 V DC.



The display of the Control Unit turns off after 15 minutes to save power during periods of inactivity.

- **External:**

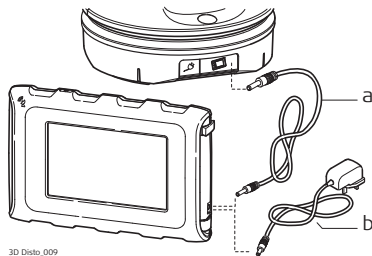

- a) Power supply cable from 3D Disto
- b) Power supply from mains supply with AC/DC adapter

- Power supply with AC/DC adapter. EU, US, UK and AUS adapter plug-ins available. Input: 100 - 240 V AC, 50/60 Hz. Output: 5.2 V DC, 2000 mA. Cable length 1.50 m.



The Control Unit powers on when plugging in the power supply adapter.

- Power supply from 3D Disto by cable: > 5 V, 2.5 A, length 2.00 m.



The Control Unit can only be charged if the 3D Disto is charged more than 25%.

3.4.3

RM100 Remote Control

RM100 Remote Control power supply

The RM100 is equipped with one AA alkaline battery, 1.5 V.

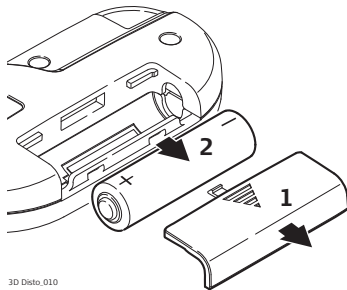



1. Push the battery cover in the direction of the arrow to open the battery compartment.
2. Replace the battery and refit the battery cover.

3.5

Software Concept

3D Disto system software

The 3D Disto software includes the central functions of the instrument:

- Several languages are integrated into this software. The preferred operating language can be chosen during the **first setup** or in the **Setting** menu.
 - The instrument has a restart function in case it does not react properly.
To restart the Control Unit press  for ten seconds.
 - To reset the software to the factory settings go to **Menu**, press **Settings** and **Reset to default**.
 - To restart the 3D Disto press  for five seconds.
-

Application programs

Several application programs are available for the instrument, supported by assistant pop-ups that guide through the workflow. These applications can be tested in a Demo mode or activated with license keys.

Demo mode

The available application programs can be tested by activating the Demo mode. This provides full software performance for 40 working hours. A pop-up reminds the user when the Demo mode expires.

To enable the application programs in Demo mode, carry out the following steps:

1. Press **Menu » Applications » Demo**.
2. All application programs are listed in the Menu and marked with  until Demo mode runs out.

Customised application programs

Customised software, specific to user requirements, can be developed using the third-party software development environment. Further information is available on request from a Leica Geosystems representative.

Software application licensing and activation

The application programs can be activated by starting the Demo mode or by entering the license key using one of the following methods:

- **Synchronisation with the MyWorld homepage on www.leica-geosystems.com:**

1. Press  and connect the Control Unit to the PC by Micro-USB cable. The Control Unit is available as a removable drive on your PC.

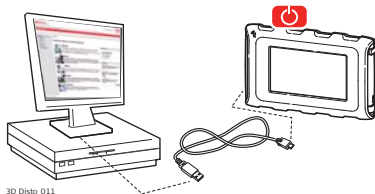

2. If the Control Unit does not recognise the PC connection automatically, press  or connect in the Menu settings.
3. If the connection works, start your internet browser and go to the **MyWorld** homepage. Register your product by entering the equipment number that can be found on the data label below the laser distance metre. Refer to "Labelling 3D Disto".
4. Choose the **MyProduct** page and press the **download key** for licenses.
5. A Windows pop-up prompts to save the license key file. Save the file in the **Licence** folder on your Control Unit.

Variations in 3D Disto Windows Software

1. Install 3D Disto software on your PC.
2. Start your internet browser and go to the **MyWorld** homepage. Register your product by entering the equipment number.
3. Choose the **MyProduct** page and press the download key for licenses.
4. Save the license key file in the **Licence** folder in the directory My Documents\Leica Geosystems\3D Disto.

- **Entering the licence key manually:**

1. Press  and go to **Menu » Device » Software » License**.
2. **Enter the key**, which you can get on the MyWorld webpage, and press **OK**.

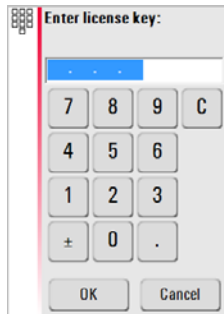

Activated application programs are available in the **Applications** menu.

Software update

1. Press  and connect the Control Unit to the PC by Micro-USB cable.

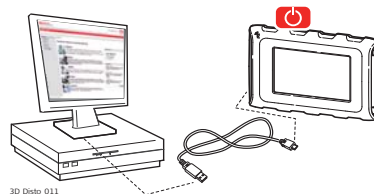

3D Disto_011



Ensure the Control Unit battery is fully charged before starting the software update to avoid data loss. Do not disconnect from PC before download has finished. Please save and export your measurement data before starting the software update.

2. If the Control Unit does not recognise the PC connection automatically press  or connect in the Menu settings.
3. If the connection works, start the internet browser and go to the **MyWorld** homepage. Register your product by entering the equipment number.
4. Go to the **MyProduct** page, choose the **Software tab** and press **Software Update key**. **MyWorld** automatically checks the firmware version on the Control Unit and starts the download in case an update is needed. The process is a step-by-step wizard guided process.
5. Disconnect the Control Unit from the PC and start the installation in **Menu » Device » Software » Update**.

Variations in 3D Disto Windows Software

1. Start your internet browser and go to the **MyWorld** homepage. Register your product by entering the equipment number.
 2. Choose the **MyProduct** page, choose the latest software version and press the **Download** key.
 3. Save the file in the **Update** folder in the directory My Documents\Leica Geosystems\3D Disto and start the installation in **Menu\Device\Software, Update**.
-

4 User Interface

4.1 Control Unit

User input

The 4.8" touch screen display is the main control device for the 3D Disto. It is used to navigate within the different applications and menus as well to control the 3D Disto.

Certain functions can also be executed using the RM100 Remote Control.



Leica Geosystems recommends using the supplied stylus on the touch screen.

4.1.1

Screen







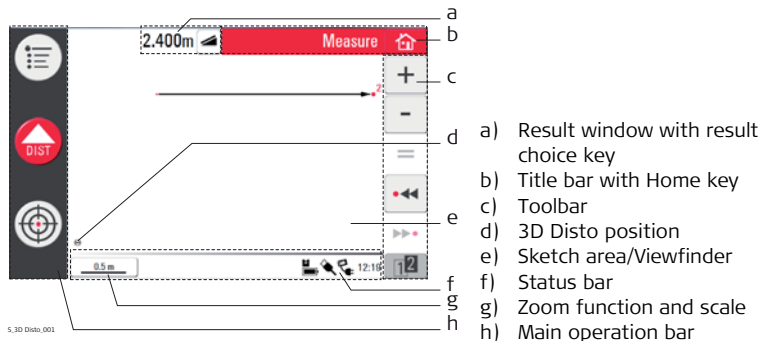

All shown screens are examples. It is possible that local software versions vary from the standard version.

Screen



Description



Element	Description
Title bar	Shows the running application.  save and close files or running applications.  shut down the Control Unit.
Main operation bar	Contains the keys Menu  , Dist  , and Viewfinder  . These keys are displayed during all applications.
Sketch area, alternating with Viewfinder	Displays measured points, lines and areas and correct position of 3D Disto in relation to measured points - either in foot print or unfold mode/face mode.
Viewfinder, alternating with sketch area	Shows 3D Disto's live video stream used to target points over longer distances, up to 50 m, exactly and to take pictures.
Results window	Displays all results such as distances, heights, slopes, areas, angles together with the corresponding result choice key, for example  . Use this key to switch between the result types. Tapping on the results opens the calculator.

Element	Description
Toolbar	Contains application-specific tool keys.
Status bar	Displays status of scale/zoom, connections, batteries, time, running function mode, assistant support.
Hourglass	 appears in case a process is running. For example while self-levelling, measurement, saving or exporting data. No key command is possible except for cancelling the process.

4.1.2

Main Operation Bar





Main operation bar description





Key	Description
	Opens the menu to start applications or to define settings.
	Starts measurement or layout of points.
	Opens, closes and locks Viewfinder.

4.1.3

Toolbar









Toolbar description

Key	Description
	Add
	Subtract
	Generate result or close polygons
	Go one point backward
	Go one point forward

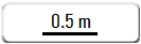









Key	Description
	Switch between the Toolbars
	Start area or volume mode
	Undo or redo last command
	Clear functions

4.1.4 Icons & Symbols







Common symbols in status bar

Icon	Description
	Indicates remaining battery capacity for the Control Unit.
	Indicates remaining battery capacity for the 3D Disto.
	Indicates USB connection between Control Unit and 3D Disto.
	Scale of sketch area and key to change zoom level.
	Indicates zoom level/magnification of Viewfinder.
	Indicates Control Unit is connected to power supply or powered by 3D Disto.
	Indicates 3D Disto is connected to power supply.
	Indicates WLAN connection is working.
	Indicates tilt sensor is turned off.

Various symbols in results window

Icon	Description
	Horizontal distance
	Tie distance
	Height, height difference
	Left angle
	Right angle
	Tilt
	Horizontal/tilted area
	Horizontal/tilted area perimeter
	Volume height/tilted volume height
	Volume/tilted volume



Room Scan result symbols

Icon	Description
	Circle size
	Point height
	Circumference
	Diameter
	Scan area
	Scan perimeter
	Scan volume

Projector result symbol

Icon	Description
	Distance between point and plane.

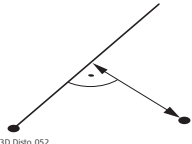
Tool Kit result symbols

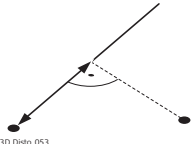
Icon	Description
	<p>Perpendicular distance of a point to the reference line.</p>  <p>3D Disto.052</p>
	<p>Distance from the reference line base point to the foot of perpendicular.</p>  <p>3D Disto.053</p>

4.2 RM100 Remote Control









Description

The RM100 Remote Control (IR) has five buttons that allow turning the 3D Disto and executing a distance measurement or point projection, depending on the application program running.



The RM100 Remote Control does not support the Tool Kit applications.

Targeting procedure

1. **Rough targeting:** hold  /  /  /  to turn the 3D Disto as long as key is pressed.
2. **Fine targeting:** short tap on  /  /  /  to turn the 3D Disto by small single steps.
3. **Measure:** Press .



The red LED at the top of the RM100 Remote Control will flash each time a button is pressed, indicating the remote is transmitting to the 3D Disto.

5

5.1



Instrument Setup

Start-up Procedure

Charging / first-time use

- **For all batteries**

- The battery must be charged prior to first use because it is delivered with as low an energy content as possible.
- The permissible temperature range for charging is between 0°C and +40°C/+32°F and +104°F. For optimal charging we recommend charging the batteries at a low ambient temperature of +10°C to +20°C/+50°F to +68°F if possible.
- It is normal for the battery to become warm during charging. When using the chargers recommended by Leica Geosystems, it is not possible to charge the battery if the temperature is too high.

- **For Li-Ion batteries**

- For new batteries or batteries that have been stored for a long time (> three months), it is effective to complete only one charge/discharge cycle otherwise they can become damaged.
- For Li-Ion batteries a single discharging and charging cycle is sufficient. We recommend carrying out the process when the battery capacity indicated on the charger or on a Leica Geosystems product deviates significantly from the actual battery capacity available.

Operation / discharging

- Batteries can operate from -10°C to $+50^{\circ}\text{C}/14^{\circ}\text{F}$ to $+122^{\circ}\text{F}$.
- Low operating temperatures reduce the capacity that can be drawn; very high operating temperatures reduce the service life of the battery.
- Discharge temperature is from -10°C to $+50^{\circ}\text{C}/14^{\circ}\text{F}$ to $+122^{\circ}\text{F}$.

**Inserting and removing the batteries**

Using another type of battery or removing the battery socket on the 3D Disto or Control Unit is not permitted. To exchange please contact your distributor or Leica Geosystems representative.



It is always recommended to shield the instrument from direct sunlight and avoid high temperature variations around the instrument.

Setup step-by-step

The following description assumes setup on a tripod but it is also possible to place the 3D Disto on flat surfaces such as a floor or boards.

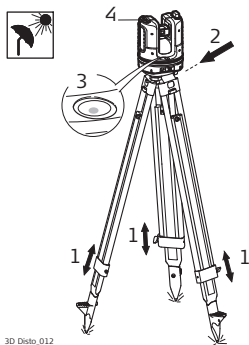

3D Disto_012

1. Set up the tripod in a suitable place where the points to be measured can be targeted well and extend the tripod legs to a comfortable working height.
2. Place 3D Disto onto the tripod head. Tighten the central tripod fixing screw.
3. Centre the circular bubble on the 3D Disto by adjusting the tripod legs.
4. Press  to turn on the instrument.

5. 3D Disto starts self-levelling: the tilt is checked by a tilt sensor and the instrument levels itself if the tilt is $< 3^\circ$.

Refer to "Description of buttons and LEDs", for information about tilt status.



Do not move the 3D Disto while self-levelling procedure is running.

6. Turn the Control Unit ON by pressing .

7. If the Control Unit is started for the first time the following screen opens:



Press  to shut down the Control Unit.

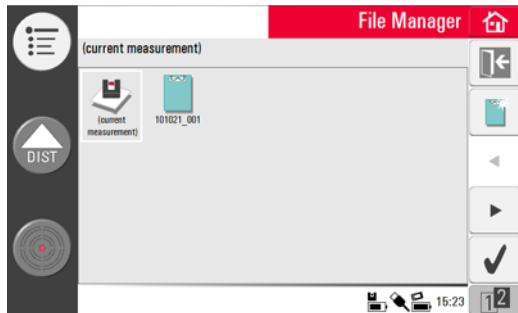

8. Choose language.
Choose time format (23:59/11:59 am-pm).
Enter date and time.
Choose units for slope, distance, and angle.
Choose decimal separator.

9. Press  to continue.

10. The following screen opens:

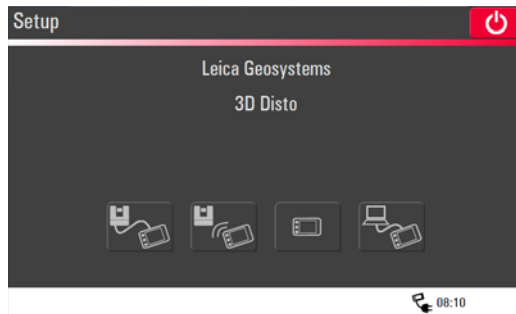

11. Choose a connection option:
- 3D Disto connected via USB cable,
 - 3D Disto connected via WLAN,
 - 3D Disto not connected,
 - PC connected via USB cable.

To work with a cable connection to 3D Disto plug in USB cable and press .



It is recommended to plug in the USB cable before turning on the 3D Disto, otherwise the instrument starts self-levelling procedure again if moved.



Do not extend the USB cable with an adapter and only use the Leica Geosystems cable delivered in the container.

To work with WLAN press .

If connection failed, connect via USB cable as described above and change the WLAN channel in **Menu » Device » WLAN channel**. Then retry WLAN connection in **Menu » Device » Connect 3D Disto**.



Change the WLAN channel if the connection is instable.

To transfer data to or from a PC connect the Control Unit to PC with USB cable and press . Refer to "5.4.4 Data Transfer" for more information.

12. If 3D Disto cannot be levelled a pop-up informs you and the in the status bar is blinking. Level the 3D Disto or cancel the levelling procedure.



Caution

For advanced users only:

If the tilt sensor is OFF the system does not compensate the tilt of the 3D Disto. All results that refer to a physically horizontal plane, for example tilt, height differences, horizontal distances, angles, areas, or volumes, now refer to the tilted horizon of the laser unit. Only the tie distance between two measured points is independent of the tilt sensor's setting.

It can be useful to disable the tilt sensor in case of vibrations, for example on construction sites or in unstable or moving environments such as on boats. Almost all measurements can still be completed and exported data can be "levelled" afterwards by CAD software.

5.2

Assistant



There is an assistant available that will guide you through all measurement tasks with illustrated pop-ups. If not needed, it can be deactivated in **Menu » Settings » Assistant**.

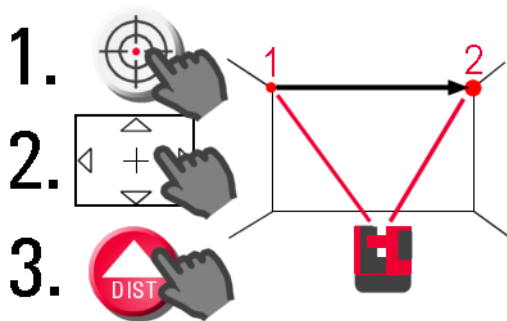

Assistant and supporting icons

If assistant is deactivated there are still supporting icons in the status bar, showing which application is running and what user action is required.

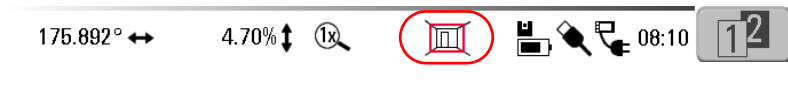

5.3 Device Configuration and Menu Settings

Device
configuration

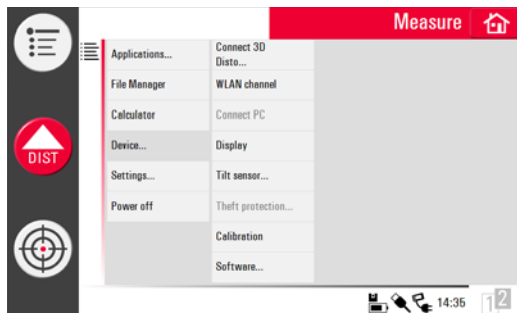

All settings on the setup screen can also be changed through the menu:

Choose **Menu » Device**.

- **Connect 3D Disto** to connect by WLAN, USB cable, or disconnect Control Unit.
- **WLAN channel** to switch between different channels if connection does not work.
- **Connect PC** to allow data transfer.
- **Display** to change display settings.
- **Tilt sensor** to activate/deactivate the tilt sensor.



Choose **ON** when working in harsh construction environment with many shocks and vibrations, apart from that choose **ON (sensitive)**.

- **Theft protection** to protect instrument with security PIN.
 - **Calibration** to check and adjust. Refer to "9 Check & Adjust" for more information.
 - **Software** to update software, to check software version on the Control Unit and the 3D Disto or to enter/activate the software license key.
-

Menu settings

Press **Menu** » **Settings**, the following options appear:

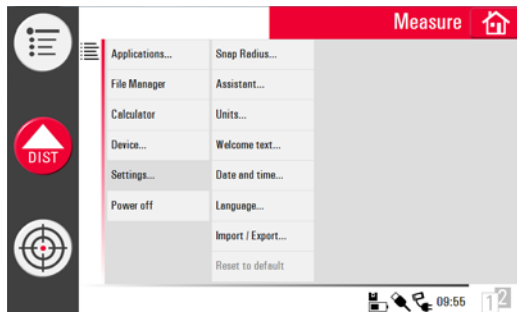

- **Snap Radius** to define the area around a point/line. This setting offers a list of points that are very close to each other to simplify their selection.
- **Assistant** to activate/deactivate the assistant.
- **Units** to change the unit settings.
- **Welcome text** to enter for example company name.
- **Date & Time** to change date and time settings.
- **Language** to choose your preferred software language.
- **Import/Export** settings to change format, coordinates and list separator.
- The instrument has a **Reset** function.
If you select the menu function **Reset to default** and confirm, the device returns to the factory settings and stack and memory are cleared.



All customised settings and stored values are also lost.

5.4 Data Management







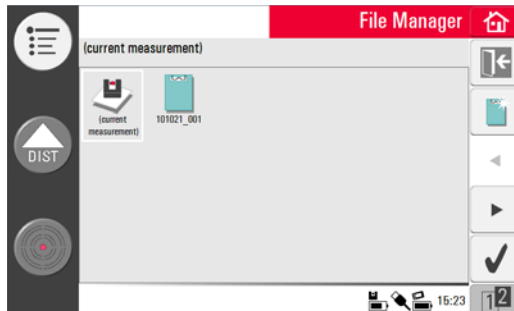





5.4.1 General

File Manager

The File Manager handles the entire data administration of measurement files, photos, Secure Points, and data transfer.



Description of keys

Key	Description	Key	Description
	Close folder/File Manager		View the selected element. Inactive at project folder level.
	Create a folder and enter a folder name with maximum 15 characters. Date and ID are default name.		Data import
	Scroll back		Data export
	Scroll forward		Rename file or folder
	Open a selected file or folder		Clear a selected file, folder, Import and Export memory-folder
	Switch between the Tool-bars		Go to higher folder level or close File Manager

5.4.2 File Manager







Description

To start, press **Menu » File Manager**.



For some applications the File Manager will be started automatically.

All files are displayed with individual icons to differentiate the type of measurement files:

Key	Description	Key	Description
	Standard measurement files		Open file/temporary file
	Area measurement		Room Scan file
	Volume measurement		Projector file







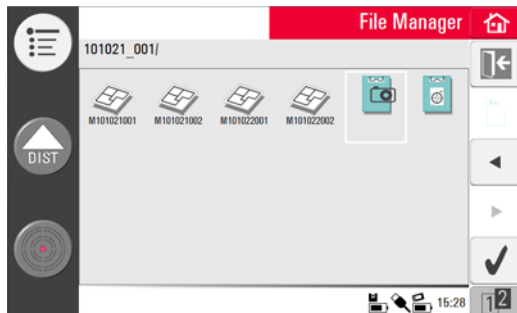

5.4.3

Photo and Secure Points Administration

Description

Photos and Secure Points are stored in separate folders.



-
- Select  and press  to open the photo folder.
 - Press  /  to choose a photo, press  to open the file.
 - Press  to view a photo.
 - Press  to clear the selected or all photos.
 - Press  to close gallery.
-

5.4.4

Data Transfer



Other USB memory sticks may be used, but Leica Geosystems recommends Leica industrial grade USB memory sticks and cannot be held responsible for data loss or any other error that may occur when using a non-Leica USB memory stick.

Data import

It is possible to import DXF files or table formats for some applications. Data should be prepared on the PC before importing. Only points are imported, no lines. The data source can be a PC or a USB stick plugged into the Control Unit.





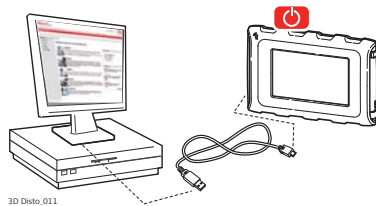

Remove irrelevant data such as frames, logos, coordinates, or orientation arrows in the DXF files before importing them.

USB Cable

1. For import from PC, connect powered Control Unit and PC by Micro-USB cable.



2. If needed, press  in the setup screen to activate PC connection. The Control Unit is now entirely controlled by the connected PC.
-  Ensure Control Unit is not connected by USB cable to 3D Disto otherwise connection to PC is not working.
3. If connection is not working go to **Menu** and select **Connect to PC**.
4. After successful connection, a pop-up window with the **Import** folder appears at your PC screen.
5. Copy the files from the PC to the **Import** folder on the Control Unit and close the window.
6. Disconnect Control Unit by choosing **Disconnect Hardware** at your PC or by key press in the pop-up of the Control Unit.
7. Open File Manager and press . Available DXF files are listed. Choose a file and press .

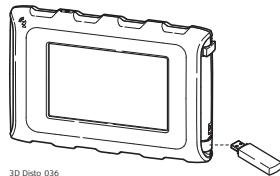

USB Stick

1. For import from USB stick, plug stick into your PC and save DXF files in the **Import** folder on the USB stick. Disconnect USB stick from your PC.
2. Plug USB stick into Control Unit.



3. Open File Manager. Press . Choose the file and press .
4. When finished, unplug USB stick.

Variations in 3D Disto Windows Software

1. Save the DXF file in the **Import** folder in the directory My Documents\Leica Geosystems\3D Disto.
 2. Open File Manager. Press . Choose the file and press .
-

Data export

Data export is started in the **File Manager**.



Select only files you really need to keep export time short.

USB Cable

1. Open File Manager, choose a folder or file and press .
2. Press in the pop-up. Connect powered Control Unit and PC by Micro-USB cable.

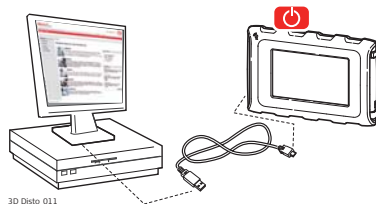



3. If connection is not working go to **Menu Device** and select **Connect to PC**.
4. After successful connection, a pop-up window with the **Export** folder appears at your PC screen.
5. Copy the files to the PC and close the window.
6. Disconnect Control Unit by choosing **Disconnect Hardware** at your PC or by key press in the pop-up of the Control Unit.

USB Stick

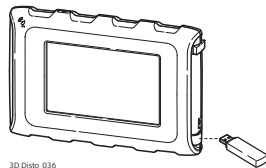
1. For transfer to USB Stick plug stick into Control Unit.



2. Open File Manager, choose a folder or file and press .
3. Press  in the pop-up.
4. When finished, unplug USB stick.



If you execute an export in File Manager and plug in the USB stick afterwards, no data will be copied to the USB stick unless you repeat the export function.

Variations in 3D Disto Windows Software

1. Open File Manager, choose a file and press .
 2. Export data is transferred to the **Export** folder in the directory My Documents\Leica Geosystems\3D Disto on your PC.
-

5.4.5

Exported files

Exported files

A key press on  generates a package of export files for documentation purposes or post processing:

- scaled 2D DXF drawing for documentation and print out including project information, all measurements and different perspectives
- DXF file 2D (X; Y), scale 1:1
- DXF file 3D (X; Y; Z), scale 1:1
- CSV file: editable, common tabular data format that lists all measurements in a chart
- TXT file: all results in editable ASCII format. Same content like CSV file
- JPG files of photos and Secure Points



Export applies the distance unit setting to exported coordinates. This setting can be modified any time before an export is executed.



The import/export settings in the menu allow to set the coordinates of the first measured point of each application. This setting must be done before the first point in a new project (e. g. a new scan) is measured; the setting does not apply retrospectively.

5.5 Calculator

Using calculator

1. Tap on the result in the result window to start the calculator.

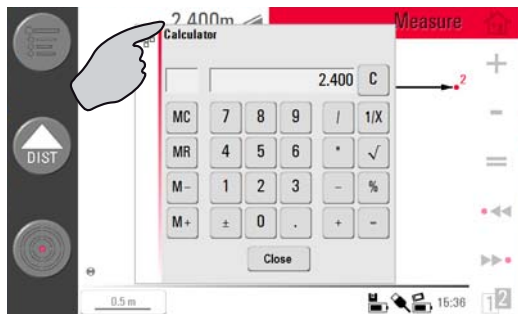

2. Another option is to press **Menu » Calculator**.
3. A pop-up opens with the following keypad:

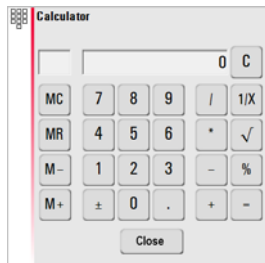

4. The memory function allows to add or subtract areas, volumes or other results.
 - Click **MC** to clear memory.
 - Click **MR** to retrieve a value stored in memory.
 - Click **M-** to subtract the displayed value from the value in memory.
 - Click **M+** to add the displayed value to the value in memory.
-  To save a certain value to the memory: Click **MC** to clear memory, enter value and press **M+**. To save the value as a negative value press **M-**.
5. Press **Cancel** to close the window again.



Calculation will not be saved in the running measurement file after closing.

6 Operation

6.1 Measurements

Description

The 3D Disto is a combination of a precise laser distance metre (LDM) and angle encoders. Targeting with the visible red laser beam allows measurement of the distance between the 3D Disto and the target and of horizontal and vertical directions toward the target. Measurements are used to establish the relation between different targets, such as horizontal distances, tie distances, height differences to determine room dimensions, angles from wall to wall, areas, volumes, plumb points, or other features.

The 3D Disto supports measuring and targeting even in difficult situations such as targeting over long distances, at inaccessible targets or in bright light conditions. A built-in tilt sensor ensures that measurements relate to true horizon or true plumb line, defined by gravity.

6.2

Viewfinder

Description

The 3D Disto has an integrated camera. It is accessible by  and it shows the camera image directly on the Control Unit display. The crosshairs in the Viewfinder image allow precise targeting and measuring even if the laser beam is not visible, for example over long distances or because of bright backlight conditions. The integrated digital zoom allows the image to be magnified by up to eight times its original size. This is particularly useful when measuring detailed surfaces in sunlight.

Example of a Viewfinder screen, first and second Toolbar shown:

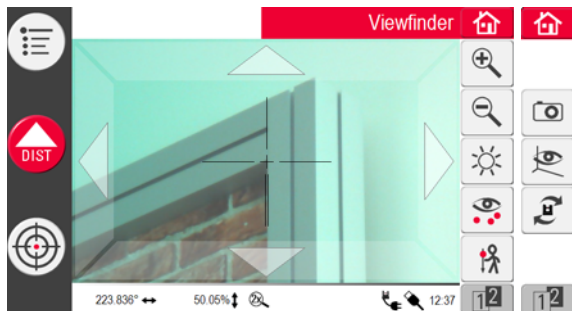

Using Viewfinder step-by-step





1. Press  to start the Viewfinder. A second key press activates the lock mode, a third one unlocks and closes the Viewfinder.

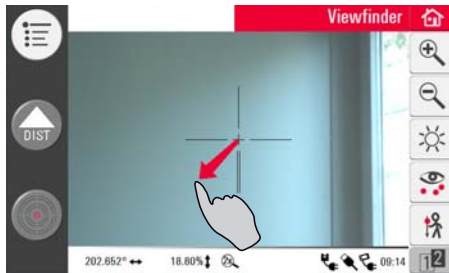

A lock symbol on a key indicates the lock mode.

2. Targeting: There are different options to target a measurement point:
 - Press the arrow keys on the screen for targeting, hold for fast 3D Disto turns and short taps for single step turns.
 - **Tap & Measure Targeting:** tap on a position on the screen. Laser point turns to this point automatically.
 - **Joystick Targeting:** is activated by long tap on the centre of the crosshairs. A red dot appears in the centre. Slide stylus on the screen to turn 3D Disto in this direction in real-time until red arrow is released. The longer the red arrow is, the faster the 3D Disto turns.



3. Press  or  to zoom in and out. There are four magnifications available. The current setting is shown in the status bar.
4. Press  to adjust the brightness of the camera.
5. Press  to display/hide all measured points. The selected point is always displayed with Point ID.
6. Press  to measure hidden points.
Select an offset tool in the pop-up:





- Vertical offset: Measure one point on any vertical target.
- Individual offset: Measure two points on a pole or other hardware.
- Offset ruler: Measure two points on the 3D Disto's offset point ruler.

An assistant leads through the workflow.



The vertical offset tool is enabled until you unlock it.

7. Press  to take pictures for documentation purposes. They are stored with name, point ID, date, and time information.
8. Press  in dark conditions to change Viewfinder picture to edge mode. Edges and corners will be highlighted in black. Only available in Microsoft Windows version.
9. Press  to choose between different turn commands:
 - Turn 90° right
 - Turn 90° left
 - Turn ?°: Enter the horizontal angle by which the 3D Disto should turn.
 - Horizon: 3D Disto goes to 0% slope in horizontal position.
 - Plumb up: This option can be used to plumb up a point by setting up the 3D Disto exactly over it. Just mark a cross on the floor. Ensure that the lines of the cross are at exactly 90° to each other and long enough to be seen when setting up the instrument above. Use the 90° markings on the 3D Disto socket for centering.



Please note that there are vertical and horizontal deviations in the movements. Do not use the turn commands for stake-out or alignment. Please work with the Tool Kit instead.

6.3 Measurement Workflow

Description

The Measure application allows determination of horizontal distances, tie distances, height differences, heights, angles, areas, volumes, slopes, or perimeters indoors but also outdoors on buildings and sites.

Measurements step-by-step

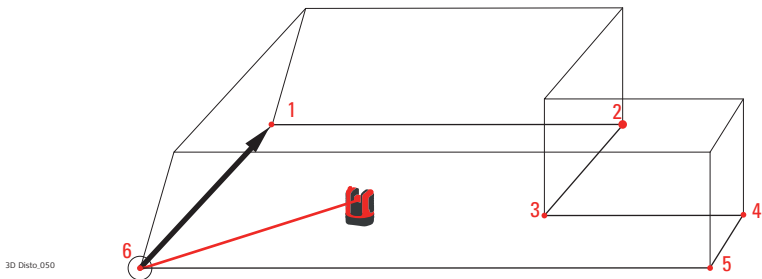

To measure for example a room's dimension, carry out the following steps:

1. Start-up the system as described in "5.1 Start-up Procedure".
2. The following screen appears:



3. To target the first point, for example a corner, press  and use the arrow keys or another method as described in "6.2 Viewfinder", to move the laser point to the desired position.



While targeting ensure the laser beam is not split along corners or edges. Otherwise this could lead to wrong measurements.



If laser point becomes a line due to an acute target angle to a wall the system measures with the centre of the line.



Measurement errors can occur when measuring toward clear liquids, for example water, or dust free glass, Styrofoam, or similar semi-permeable surfaces. Measurement time may increase when measuring to non-reflective and dark surfaces.

4. Press  to measure. Measured point appears in the sketch area.



The position of the 3D Disto symbol in the sketch changes in correct relation to the measured point. The first measured point is always displayed on the left side of the sketch area.

5. Target the second point and proceed as described in steps 3. to 4. A line is displayed from the first to the second measured point.

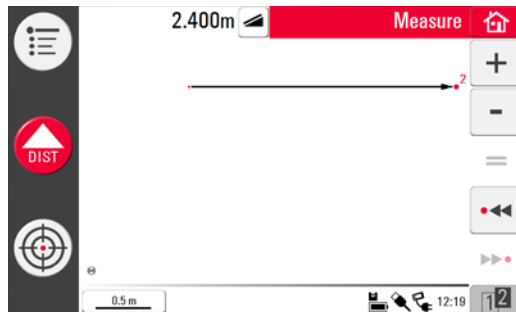

6. After the third point is measured a proposed "closing line" appears between the first and last measured point. The selected line is always highlighted with a bold line and an arrow in the direction of measurement.

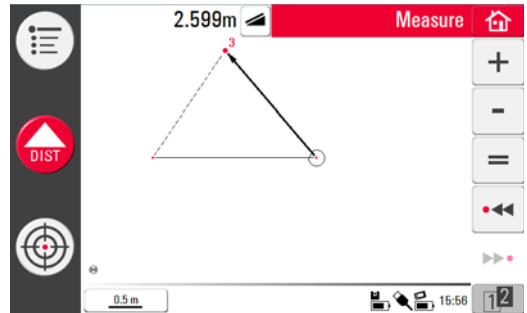

7. Proceed as described for measuring further points or use **=** to close/finish the polygon.



In special situations the proposed line is not available. Polygons can also be closed and results created by drawing a line with the stylus between the two points to be connected.

8. To measure the room height select a floor point in the sketch area. Then target and measure the ceiling corner above it.

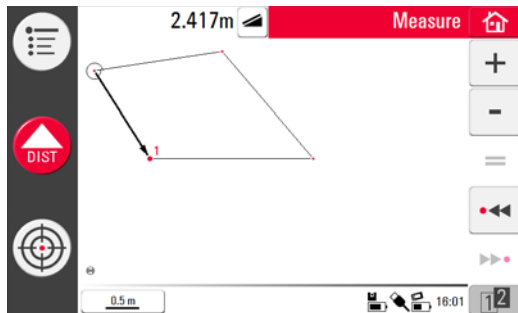

Please note that the sketch shows a foot print view. Measured floor and ceiling points may cover each other. Use or to select points and results.

9. Proceed as described previously to measure the ceiling.
10. Press to undo the last command.
11. Press to redo the last command.
12. Press or and to clear measurements and results.
13. Press to choose between save, save as, clear screen, close measurements without saving.



It might be better to organise the measurements in different folders to keep the amount of data in one folder at a meaningful limit for both working and for export.

6.4

Touch Screen in Sketch Area

Selection of elements

Any element can be selected by fingertip or by stylus. Polygons that consist of added or subtracted lines cannot be selected by direct touch.

Line drawing between arbitrary points

This is a feature to determine results, not to draw a line.

The **=** key of the Toolbar only accepts a line proposed by the system.

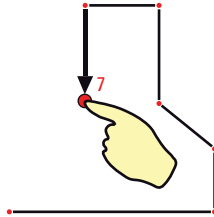

3D Disto_047

1. Select point.

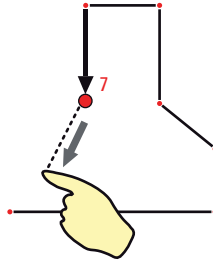

2. Keep finger or stylus on screen and slide to desired point.

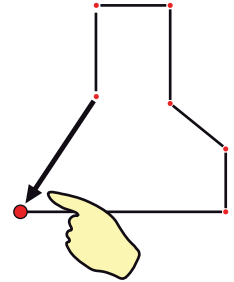

3. Release touch screen when dotted line changes to dashed line. Results between these two points are displayed in the results window.

6.5**Addition and Subtraction**



During and after measuring you can add or subtract selected elements.

The following values can be added:

- Horizontal distances
- Tie distances
- Heights (in certain cases)



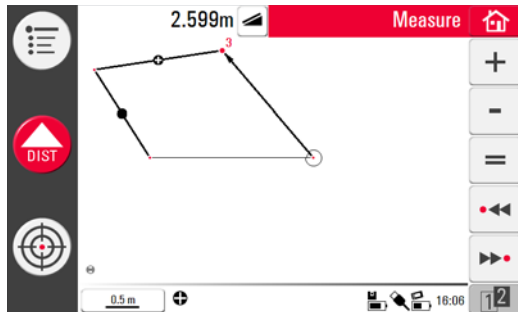

Area and volume results can be added or subtracted by using the memory function in the calculator.

Addition and subtraction after measurement step-by-step

1. Select element by fingertip, stylus or $\bullet \ll / \gg \bullet$.
2. Press $+$ or $-$ for addition or subtraction. The corresponding symbol appears in the status bar. The first selected line or area is highlighted with black bullet symbol.
3. Select next element and press $+$ or $-$ for addition/subtraction again or $=$ to close the sum and/or finish the adding/subtracting function.
4. The added/subtracted elements get a \oplus or \ominus icon.
5. The sum is displayed in the results window.



Addition and subtraction during measurement step-by-step

1. Press  , target and measure the first two points with  .
 You have to measure two points before $+$ or $-$ is active as points cannot be added or subtracted.
 2. Two points with a line connection appear in sketch area.
 3. Press $+$ or $-$ for addition or subtraction. The corresponding symbol appears in the status bar. The first selected line is highlighted with black bullet symbol.
 4. Press  , target to measure a further point. Press  .
 5. Press $+$ or $-$ to add/subtract next distance (line) or continue measuring if you would like to skip a point distance to be added/subtracted.
 6. Proceed until ready to close the sum and/or finish the adding/subtracting function. Then press $=$.
-

6.6

Area & Volume Calculations

Description

The 3D Disto can also help determine areas and volumes. Both can be determined during or after measuring.

1. Press **1****2** and choose .
2. A pop-up offers the choices **horizontal area/volume**, **tilted area/volume**, or **quit the application**. The sketch area's content is retained but the Toolbar changes.

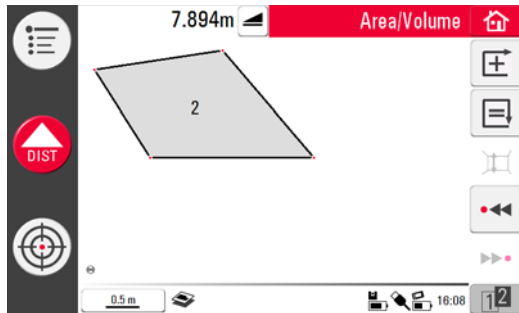







Each area can be managed in both the **Horizontal Area** or **Tilted Area** application.

6.6.1

Horizontal Areas/Volumes



Calculation during measurement step-by-step

1. Either select start point in sketch area or open Viewfinder if sketch is empty.
2. Target and measure a point with . Viewfinder is closed and point displayed in sketch.
3. Press  and measure next point with .
4. Press  to define line as part of the area. Proceed with measurement and line selection. The polygon can be closed by pressing . The area is highlighted in grey.
5. Pop-up appears to choose between the different options to define the height: **Enter height for volume, Measure height, Close List.**
6. **Measure height:**
Viewfinder opens, target and measure point on floor with , followed by point on ceiling. The height appears in the results window.
 You can measure the points anywhere on the floor or ceiling area.
OR:
7. **Enter height:**
Default for the entry is 0.000 m. Enter a desired value and press **OK** or **Cancel**.

Calculation after measurement step-by-step

OR:

8. **Cancel:** the result is an area.
 9. To change the height or to calculate the volume with a selected area press  and proceed as described in steps 3. to 4.
-

1. Select line to be added to area and press .
 2. Proceed that way for all lines and press .
 3. For volume calculations go on as described from 5. to 9., page 103.
 4. Quit application by pressing .
-

6.6.2

Tilted Areas

Description

- This option offers the same functionality as the Horizontal Area application but the results differ.
- The results window shows the tilted area, tie distances, tilt perimeter, and tilt of the plane.
- An arrow in the tilted area shows the tilt direction.



Volume calculation is also possible for tilted areas.

7

Software Applications

7.1

Overview

Description

There are a variety of software application programs available addressing a wide spectrum of construction tasks and facilitating daily work.

- **Tools:**
Software license protected application featuring a **Tool Kit** with smart measuring and set-out tools and **Location** routine to easily and correctly check and relocate the position of the 3D Disto.
 - **Room Scan:**
Provides practical features to measure room dimension, walls, windows, stairs, and other details with reference height, manually or automatically.
 - **Projector:**
Enables layout of grids and other designs on floors, ceiling, or walls.
-

7.2 Tool Kit

General

In addition to the standard applications this program features:

- Comfort Plumbing,
- Comfort Targeting,
- Comfort Level,
- Metre Mark,
- Height Tracking, and
- Parallel Line.



The Tool Kit applications offer quick, precise and easy-to-use tools for plumbing, metre marks, heights, and parallels. After each layout task the respective tool has to be restarted. A pop-up offers to continue with the same reference or to measure a new one. Data is not stored and cannot be imported or exported. Remote Control functionality is not supported in these applications.

7.2.1

Comfort Plumbing



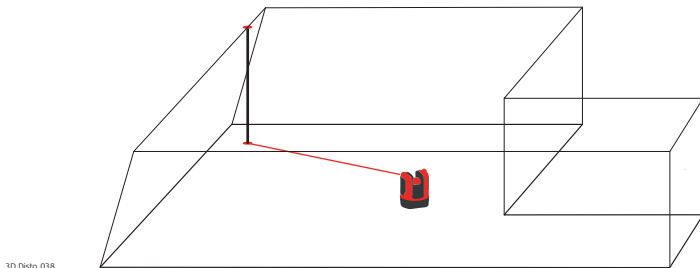

Description

Comfort plumbing allows plumbing any point up or down without standing above it.

This tool can be very helpful for installation of drywall.



**Comfort plumbing
step-by-step**

1. Start application in **Menu » Applications » Tool Kit.**
 2. An empty sketch opens. The running application stays open in the background.
 3. Press  on the Toolbar.
 4. Viewfinder opens. Target and measure the point to be plumbed. Press .
 5. Viewfinder stays open. Roughly target expected plumb and press .
 6. If plumb is found the laser flashes to indicate the exact position.
 Refer to "8 Error Messages" for information about possible error messages.
 7. Press  to close Tool Kit.
-

7.2.2

Comfort Targeting

Description



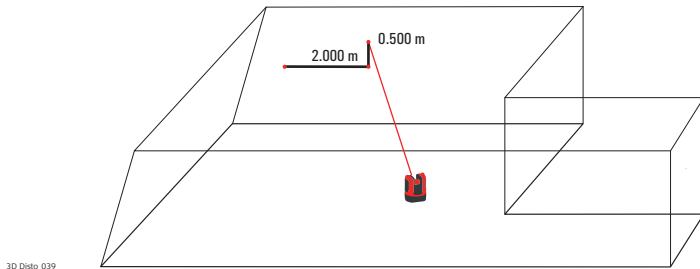

Comfort targeting allows laying out a point relative to a reference point on vertical surfaces.

This tool can be very helpful to install lights or pictures at regular distances on walls.



Use this feature only on vertical surfaces. On tilted surfaces the layout position will not be correct.

**Comfort targeting
step-by-step**

1. Start application in **Menu » Applications » Tool Kit**.
 2. The running application stays open in the background.
 3. Press  on the Toolbar.
 4. Viewfinder opens. Target reference point on the wall. Press .
 5. Pop-up prompts to enter value for left or right distance to reference point. For left turn set a negative value. Press **OK** to confirm the value.
 Enter 0 to lay out points with only vertical offsets to the reference point.
 6. Laser point flashes to indicate exact position. Pop-up appears to enter vertical value (= distance above/below layout point). Default value = 0. Set a negative value for down turn. Press **OK** to confirm the value.
 Refer to "8 Error Messages" for information about possible error messages.
 7. 3D Disto turns and lays out the correct position.
 8. Laser point flashes to indicate exact position.
 9. Press  to close Tool Kit.
-

7.2.3

Comfort Level



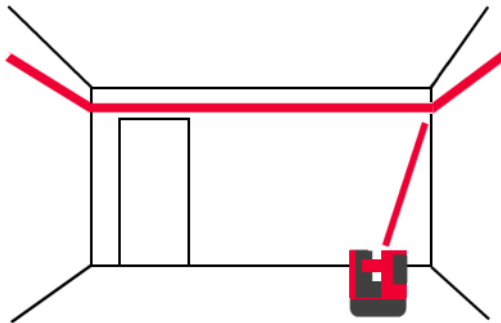

Description

Comfort levelling keeps the laser point at the same level when you turn the 3D Disto horizontally.

This tool can be very helpful for the installation of suspended ceilings or to mount pictures at the same height on walls.



**Comfort levelling
step-by-step**

1. Start application in **Menu » Applications » Tool Kit**.
 2. The running application stays open in the background.
 3. Press  on the Toolbar.
 4. Viewfinder opens. Target reference height on the wall. Press  .
 5. Viewfinder stays open. Roughly target the assumed layout point and press  .
Laser point flashes to indicate the exact height position.
 Refer to "8 Error Messages" for information about possible error messages.
 6. Press  to close Tool Kit.
-

7.2.4

Metre Mark



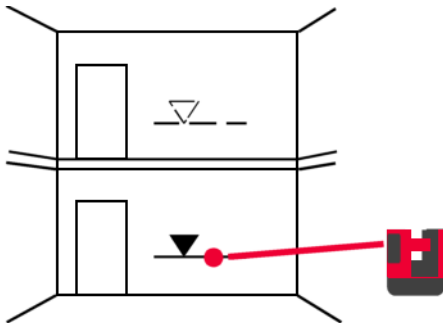

Description

The **Metre Mark** tool refers to a metre mark or reference height and allows laying out any desired height.

This tool can be very helpful to mark the metre mark at several places in a room or lay out heights on several building levels.



**Metre mark
step-by-step**

1. Start application in **Menu » Applications » Tool Kit**.
 2. The running application stays open in the background.
 3. Press  on the Toolbar.
 4. Pop-up prompts to enter the height and measure that reference height.
 5. Viewfinder opens. Target reference point on the wall. Press .
 6. Pop-up prompts to enter an absolute height to be laid out.
 7. Viewfinder opens. Roughly target close to expected absolute height on the wall.
Press .
 8. Laser point flashes to indicate the exact position of the absolute height.
 Refer to "8 Error Messages" for information about possible error messages.
 9. Press  to close Tool Kit.
-

7.2.5

Height Tracking



Description

Height Tracking allows determination of the height of a target that cannot be measured directly.

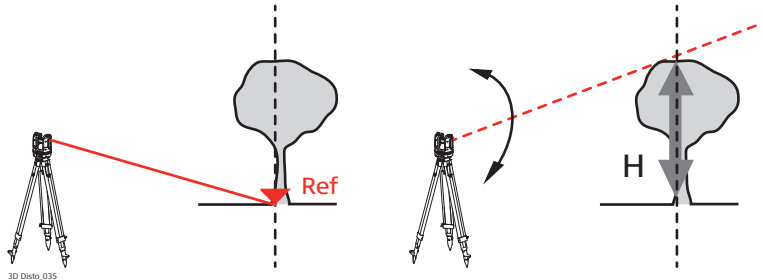
This tool can be very helpful for measuring the height of a tree or power lines.



**Height tracking
step-by-step**

1. Start application in **Menu » Applications » Tool Kit.**
 2. Press  on the Toolbar.
 3. Viewfinder opens. Target and measure a reference point at the same horizontal distance as the point you would like to measure indirectly.
 Do not move the 3D Disto horizontally too much after reference point has been measured, otherwise the result will be incorrect.
 4. Viewfinder stays open and measured point is displayed.
 5. Target the point you would like to measure indirectly as exact as possible. The height difference to the reference point is displayed and updated in real-time in the results window.
 6. Close the Viewfinder to finish the application.
-

7.2.6

Parallel Line



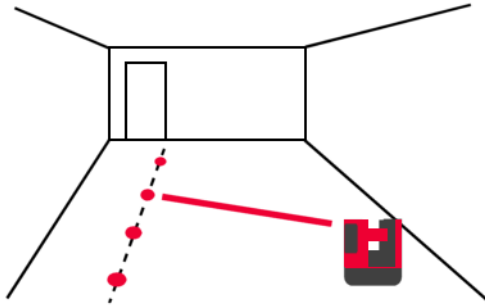

Description

Parallel line allows laying out lines parallel to a reference line on walls, floors, or tilted surfaces.

This tool can be very helpful to align tiles or drywall profiles.



**Parallel Line
step-by-step**

1. Start application in **Menu » Applications » Tool Kit**.
 2. Press  on the Toolbar.
 3. Viewfinder opens. Target and measure start and end point of the reference line.
 4. A pop-up prompts to enter parallel distance to the left or right of the reference line. Press **OK** to confirm the entered value.
 5. Viewfinder opens to roughly target layout point. Press . Laser point flashes to indicate the exact position on the parallel.
 All points have to be measured on the same surface.
 6. Press  to close Tool Kit.
-

7.3

Location

Description

The **Location** functions allow to change the position of the 3D Disto. **Secure Points** are placed by the user and make the positioning procedure easy.

Secure Location step-by-step

If you want to continue a measurement in the same room at a later time and secure the current position of the 3D Disto and the measurement geometry, you can measure and save **Secure Points**.



You have to measure two points first before **Secure Points** can be saved.

1. Label and affix three to five self-adhesive target marks on walls, ceiling or floor around your working area. Ensure that the target marks are spread out.

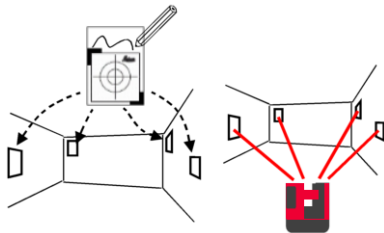



Instead of target marks you can use any other point that is well fixed: draw a cross on the wall or hang the ruler for offset points on a nail and use one of its marks.

2. Press **Menu » Applications » Location » Secure Location.**

3. Viewfinder opens. Target the **Target marks** as precisely as possible and

press  to measure.

4. 3D Disto takes a photo and saves it with coordinates, labelled with ID and date.

5. Pop-up prompts **Measure more Secure Points? Yes/No.**

6. Proceed as before and measure at least three Secure Points. After saving a minimum of three points you may leave the application by choosing **No.**



You can add more Secure Points at any time.



Ensure you have enough well-measured Secure Points around your working area. Even if one is lost there must be at least three for a successful relocation.

Relocation step-by-step

This feature allows the relocation of the 3D Disto into a defined coordinate system previously established by the **Secure Location** procedure, for example to complete a previous measurement.



Use a 3D Disto position that allows targeting and measuring at least three Secure Points around your working area.

1. Press **Menu » Applications » Location » Relocation**.

2. A pop-up prompts you to define the tolerance.

Press **OK** to confirm the value.



A lower tolerance increases the accuracy of your measurements and requires precise aiming and visibility of the Secure Points.

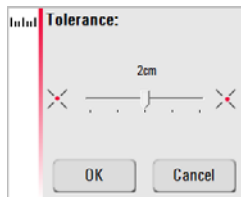

3. If there are no Secure Points in the memory, pop-up prompts **Not enough Secure Points in the memory**.



If there are no Secure Points available but your measurement must fit to the geometry of a previous one, just start your measurement with the same Base Line points. These are the first two points of a measurement.

4. If Secure Points are available, folder opens. Choose a Secure Point by pressing ◀ / ▶ or by tapping on the screen. Press 👁 to enlarge.

Press 📁 to see all Secure Points of the whole memory.



5. Press ✓ to confirm point.
6. Viewfinder opens. Target the target mark shown in the photo as precisely as possible and press 📏.





The first two Secure Points should be far apart from each other.

7. If successful, pop-up appears **Measure next Secure Point? Yes/Cancel.**

8. If **Yes**: Folder opens to choose next Secure Point. Proceed as described in 4. to 7. for 2nd and 3rd point.



If the first two Secure Points were measured successfully the 3D Disto roughly turns to the next chosen Secure Point. You just have to do the fine targeting and press .

9. When you have measured three points successfully a pop-up shows **OK. Measure more Secure Points? Yes/No/Cancel.**
10. Press **Yes** to continue and proceed as described in 4. to 7.
11. Press **No** to finish. If successful, a pop-up displays the dimensions between old and new position: **XXXm; Height: XXXm; OK/Cancel.** Accept with **OK** or **Cancel** to measure further points.
12. If Relocation was not successful, pop-up prompts **Out of tolerance! Measure more Secure Points? Yes/No/Cancel.** Go on as described in 4. to 11.
13. Press  to close the application.
-

**Location Check
step-by-step**

If the 3D Disto was unintentionally moved, for example got bumped, the geometry of the measured points will no longer fit with that of the previously measured points. Start a Location Check to sustain the current accuracy/geometry.

1. To initiate a Location Check press **Menu » Applications » Location » Location Check**.



If there are no Secure Points in the memory, no Location Check is possible.

2. If Secure Points are available, select Secure Point and press . The 3D Disto will target the Secure Point automatically. Check laser point position with target mark. Proceed that way for checking further points.



If laser point does not target the centre of the target mark, Relocation is recommended.

3. Press  to close **Secure Point** gallery.



All Location applications can be cancelled by pressing .

7.4

Room Scan

General

This application program measures room dimensions, including details. For these measurements several additional features are available:

- Reference height
- Automated scans
- Single point measurement (points without line connection)
- Coordinate export
- Unfold tool to switch between foot print and face view
- CAD tools

Ideal for measuring rooms with non-square corners or curved walls, inaccessible points, slopes or areas, and to measure the position of details like sockets or pipes.

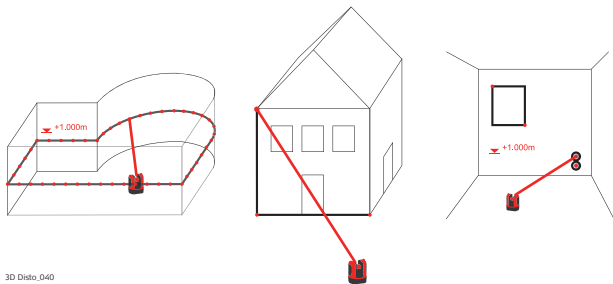

7.4.1

Manual Measurement

Manual measurement step-by-step

1. Press **Menu » Applications » Room Scan**.
2. Pop-up prompts to enter and measure reference height. Enter the value and press **OK**.

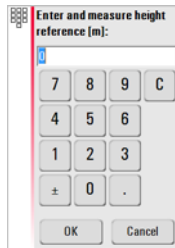





3. Viewfinder opens. Target the reference height and press

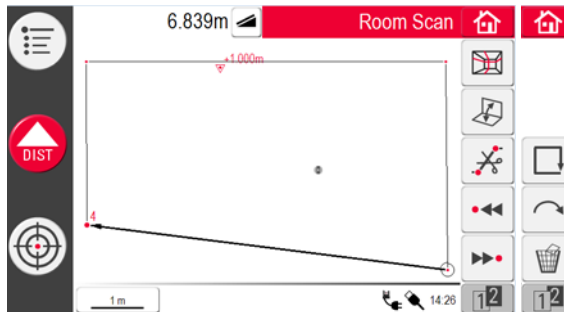

4. Reference height is displayed in the sketch area.



5. For further measurements proceed as described in "6.3 Measurement Workflow". Please note that Toolbar changed:  for scan functions,  to switch between footprint and face views,  to close polygon, and  to disable line drawing.

7.4.2

Unfold Mode

Description

Room Scan allows switching the view in the sketch area from foot print to unfold mode/face mode. This option is active when a line is selected.

Unfold mode step-by-step

1. Select a horizontal line between two points.
2. Press . Sketch area changes from foot print to face view.

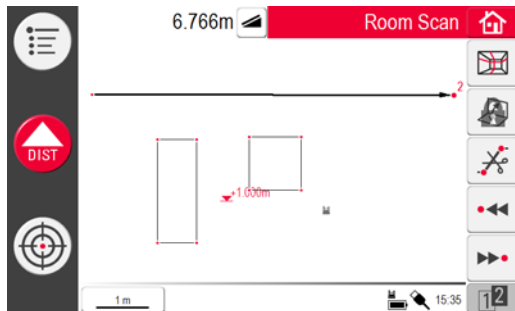

3. All measured points on the vertical plane are displayed.
4. To measure details or wall dimensions proceed as described in "6.3 Measurement Workflow".
5. When measurements are finished, switch to foot print view by pressing  again to unlock.



An automatically generated scan line can be unfolded as well.

7.4.3

CAD tools

Overview

CAD tools is a set of drawing functions. They appear as a submenu after a long tap on a line or point, like below:

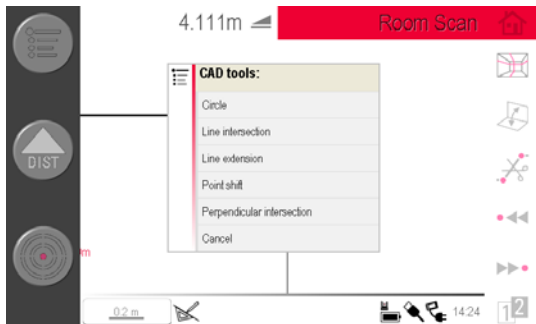

The menu might vary from context. If activated, the drawing icon  is active in the status bar. The following tools are available:

Tool	Condition
Circle	Point Selected
Rectangle	Face-view mode only, line selected, line must not be vertical
Line Intersection	Foot-print mode only, line selected, line must not be vertical
Line Extension	Line must be selected
Point Shift	Foot-print mode only, line selected, line must not be vertical
Perpendicular Intersection	Foot-print mode only, line selected, line must not be vertical

Circle tool

The circle tool's purpose is mainly to draw a circle on points like sockets or holes.

1. Target and measure a point and activate circle function by a long tap on the point in the sketch area. The CAD tools menu opens. Select **Circle**. Pop-up opens. **Enter diameter**. **OK/Cancel**.



2. Enter the value and press **OK**. Circle is drawn around the chosen point.

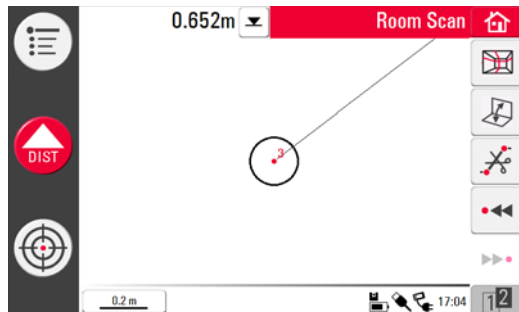

3. To clear the circle, enter 0 as value for diameter or press .
4. The results window contains radius, circumference and size of the circle.

Rectangle tool

This tool only works when changing the perspective to unfold mode/face mode and allows measurement of a diagonal and generation of a rectangle, for example to measure windows.

1. Press  to change perspective to face view.
2. Measure 1st and 2nd point of the diagonal of a rectangle, for example a window, and activate the CAD tool by long tap on the line. The CAD tools menu opens. Select **Rectangle**. Pop-up prompts **Transform into rectangle? Yes/No**.
3. Diagonal changes to a levelled rectangle.

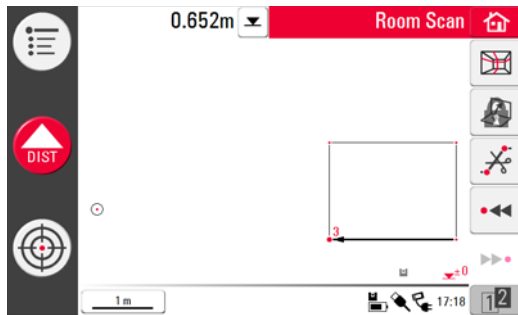

Line Intersection Tool



The **Line Intersection tool** finds the intersecting point between two lines.

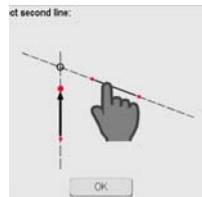

Intersection location is computed two-dimensionally in the X-Y plane. Intersection point height is computed by extrapolation of the 1st line.

1. Target and measure two points or select an existing line. Activate the CAD tools by a long tap on the line in the sketch area. Select **Line Intersection**.
2. The assistant prompts for selecting a second line. Press **Ok**.

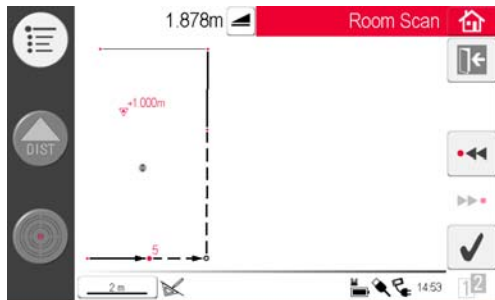

3. Select a second line.
The intersection point is proposed once a line is chosen:



4. To cancel, press . After  was pressed, the intersection point is generated and the connecting lines to the existing points are added.
-

Line Extension Tool The **Line Extension tool** expands a line by a manually entered distance value.





Line Extension end-point is computed as the 3-dimensional extrapolation of the selected line.

1. Target and measure two points or select an existing line. Activate the CAD tools by a long tap on the line in the sketch area. Select **Line Extension**.
2. The pop-up prompts for the extension length. Enter a value and press **Ok**.

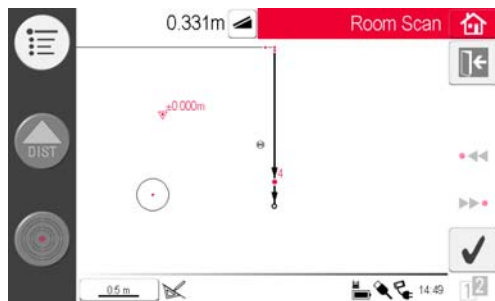

3. The Line Extension end-point is proposed:



4. To cancel, press . After  was pressed, the new point is generated and the connecting line to the previous point is added.
-

Point-Shift Tool

The **Point Shift tool** creates a new point by providing lateral movement value along an existing line, offset and offset angle.



Point-Shift location is computed two-dimensionally in the X-Y plane. New point height is computed by extrapolation of the selected line.

1. Target and measure two points or select an existing line. Activate the CAD tools by a long tap on the line in the sketch area. Select **Point Shift**.

2. Assistant and pop-up ask for the length movement.

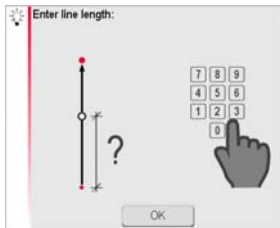

Press **OK**.



Enter a value and press **OK**.

3. The length shifted point is proposed:

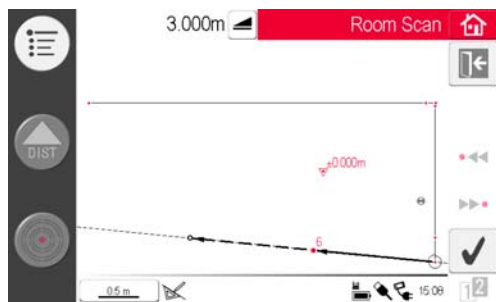

4. To cancel, press . Press  to continue.

5. Assistant and pop-up ask for the direction angle for the offset.

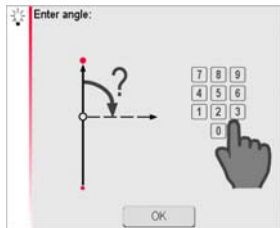

Press **OK**.



Enter a value and press **OK**.

6. The angle for offset direction is proposed:

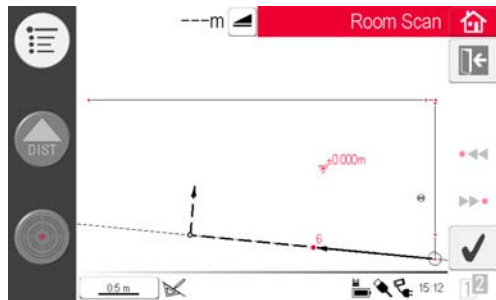

7. To cancel, press . Press to continue.

8. Assistant and pop-up ask for the offset.

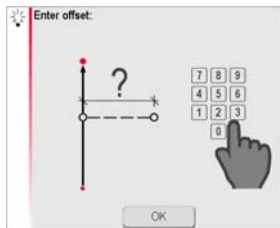

Press **OK**.



Enter a value and press **OK**.

9. The shifted point is proposed:

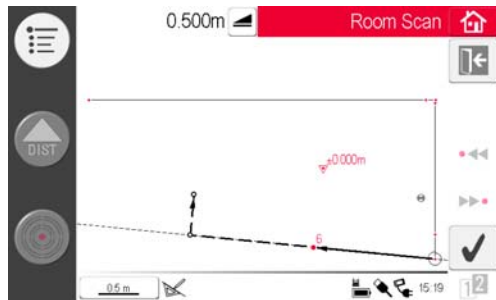

10. To cancel, press . After was pressed, the new point is generated and the connecting line to the previous point is added.
-

Perpendicular Intersection Tool



The **Perpendicular Intersection tool** finds the perpendicular projection of a point on the selected line.

Intersection location is computed two-dimensionally in the X-Y plane. Intersection point height is computed by extrapolation of the 1st line.

1. Target and measure two points or select an existing line. Activate the CAD tools by a long tap on the line in the sketch area. Select **Perpendicular Intersection**.
2. The assistant asks for selecting a point. Press **Ok**.

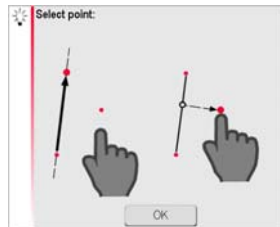

3. Select the point. The intersection point is proposed once a point is chosen:

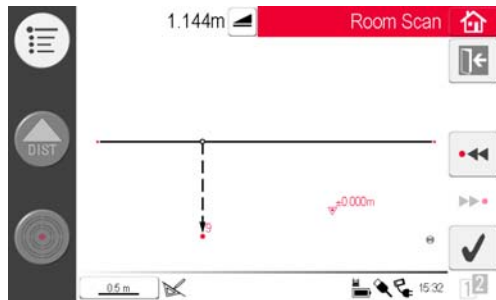

4. To cancel, press . After was pressed, the intersection point is generated and the connecting lines to the existing points were added.
-

7.4.4 Automated Scans

Description

This tool executes automated horizontal, vertical and slope profile measurements and surface scans.

Scanning, Start step-by-step

1. Press  to start scan.
2. Pop-up offers line scans and surface scans.

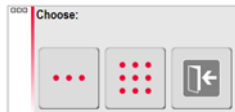

Horizontal scan, step-by-step

3. Press  to select line scans. Pop-up prompts scan types.



4. Press  for horizontal line scan.
5. Viewfinder opens to target and measure start point.
6. Pop-up prompts to define scan direction **right/from ... to/left**. Right for 360° clockwise, 'from ... to' for a defined interval, left for 360° scan counter clockwise. Choose one of these options to continue.





7. If you choose **from ... to** Viewfinder opens to measure scan end point.

Press .

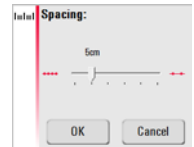
8. Pop-up prompts to define spacing of the measurement. Choose an interval and press **OK** or go to the rightmost position to enter individual intervals.







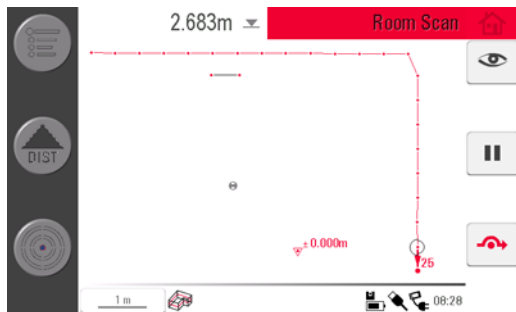

For best scan results do not choose small intervals at long distances.

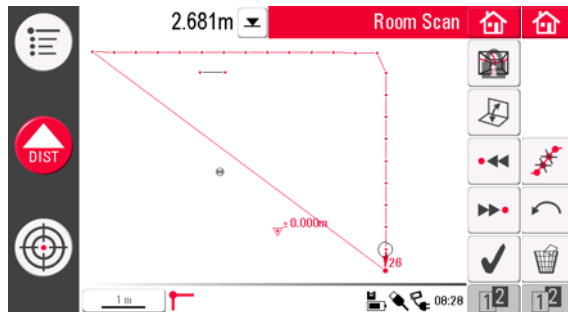
9. Press **OK**. Scan starts. Toolbar changes.
10. Press  to start the camera. Press again to unlock.
11. Press  to change scan spacing, skip the rest of the scan, continue scan, or cancel scan.
12. Press  to skip a scan point that you do not need or that causes problems.



13. If scan is finished pop-up prompts **Ready. Edit Scan? Yes/No.**



14. If **Yes**: New Toolbar appears, e.g. to measure missing points with DIST or delete unneeded points with Trash key Symbol.
- Press  or  to select points.
- Press  to change view and measure for example wall details.
- Press  to start a scan simplification that automatically clears aligned points.
- Press  to finish the scan.
15. Press  to save and close measurement file.

**Vertical scan,
step-by-step**

1. Press  to select line scans. Pop-up prompts scan types.



2. Press  for vertical line scan.
3. Viewfinder opens to target and measure start point.
4. Pop-up prompts to choose scan orientation:
Perpendicular to wall or **Free**.

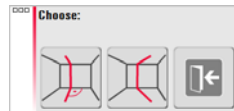

- **Perpendicular to wall**

1. 3D Disto measures the surface around the measured start point automatically. Await the next pop-up.
2. Pop-up prompts to define measurement direction **up/from ... to/down** followed by spacing of measurement points.



3. If you choose **from ... to**, Viewfinder opens to measure end point before spacing can be defined. Press .
4. 3D Disto starts scan at the start point. Proceed as described in "Horizontal scan, step-by-step", page 149 ff.

- **Free Profile**

1. Viewfinder opens to target and measure a point on the opposite wall.

Press .

2. Pop-up prompts to define measurement direction **up/from ... to/down** followed by spacing of measurement points. If you choose **from ... to** 3D Disto scans only from point to point, not 360°.





3. Proceed as described in "Horizontal scan, step-by-step".

Slope scan, step-by-step

1. Press  to select line scans. Pop-up prompts scan types.

Select  for slope line scan.



2. Viewfinder opens to measure start point. Target and press .
3. Target scan end and press .
4. Proceed as described in "Horizontal scan, step-by-step".



The slope scan does not work on horizontal surfaces.

Surface scan, step-by-step



1. Press  for surface scan.
2. Pop-up offers three scan options: horizontal, slope and vertical. Select your preference according to the surface you want to scan.





Use vertical or horizontal scan to measure on walls, floor and ceiling.

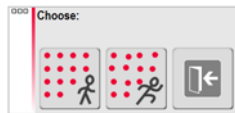

Slope scan is ideal to check the flatness of any surface, independent of it's inclination.

3. Select "precise" or "speedy" option. "Precise" finds the exact position of each scan point. "Speedy" prioritises short measuring time and robustness. Measurement accuracy is equal.



4. The Viewfinder opens for measurements to define the scan area:
 - horizontal & vertical scan: measure 2 edges (3 points). The area is completed automatically
 - slope scan: measure the borders of the scan area and press  to continue.

Proceed as described in steps 8. to 11. in "Horizontal scan, step-by-step".



The deviation of each scanned point to the reference plane is displayed in the result window. 



For geometric reasons, scan volume computation is an approximation.



7.5

Projector

General

This application projects points or geometrical grids onto a horizontal, vertical, or sloped (= "free") plane. Design data in DXF or table format can be imported or a grid's geometry can be entered manually.

Projecting grid points is ideal when installing suspended ceilings.

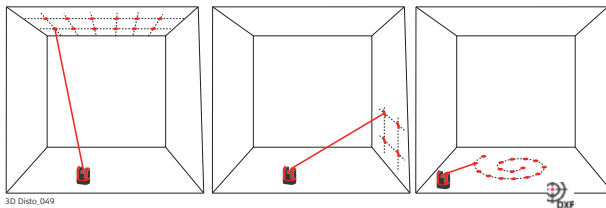

7.5.1



Workflow

Projector, Start

1. Press **Menu » Applications » Projector**.
A pop-up offers three scan modes: horizontal, slope and vertical.
2. Select your preference according to the working area.
3. The Viewfinder opens to measure the working area.





Measuring the Working Area

1. Measure all important objects you want to consider (edges, corners, etc.)
 For horizontal mode only: the first measured point defines the level that all following points refer to.
 2. If  is enabled, press this key to close the outline. Then measure further points of interest (slope mode only).
 3. When all points are measured, press  to continue.
-

Point Design

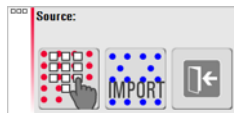
1. A pop-up offers two options to define the projection points: Grid mode for a regular pattern and Import mode for individual DXF or CSV files.





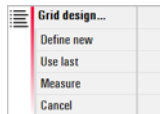

Use the  key at any time to go back to the working area measurement.

- **Grid mode**

1. Press  to start Grid mode.
2. Pop-up appears to choose between **Define new**, **Use last** or **Measure**.









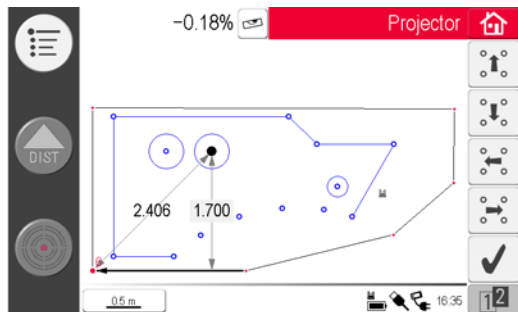

3. Select your preferred option:
 - **Define new**: use the subsequent tools to enter the grid's geometry.
 - **Use last**: restore the last grid design that was entered.

- **Measure:** follow the guided workflow to lock onto an existing grid. This option skips the following step **Adjustment**.
 - **Import mode**
 1. Press  to start Import mode.
 2. The file manager displays all imported DXF and CSV files. Select a file. Press  if you want to check the content via viewer.
 -  The head line of the viewer displays the dimension of the file. Change the setting for **distance** in the menu if the scale does not fit to the working area!
 -  To import points from a list, enter coordinates X, Y or Y; X in a text editor and save the file with extension CSV. If the import does not work properly check the Import/Export settings in the menu.
 3. Press  to continue.
 4. Projection points are displayed and ready for adjustment.
-

Design Adjustment

1. **Aligner** opens. The point design is now displayed in the working area and must be moved to the desired position. Use the following tools:



2. Each point and line can be selected by fingertip or stylus.
 3. The grid can be moved up, down, left, and right on the screen in small steps using . The perpendicular distance from a selected grid point to a reference line is displayed. Tap on this distance to enter a value.
 4. Press  for further grid alignment tools.
 5. Press  to reset the grid position.
 6. Press  to align grid parallel to a selected line.
Lines between design points can be drawn on the screen if necessary before use of the Parallel tool.
 7. Press  to turn the grid by 90°.
 8. Press  to place the grid exactly on a reference point.
 9. Press  to proceed.
Use the  key at any time to go back to **Point Design**.
-

Point projection

1. In layout mode the Toolbar changes and you can start to project the grid. Use the arrow keys to select a point and press  .

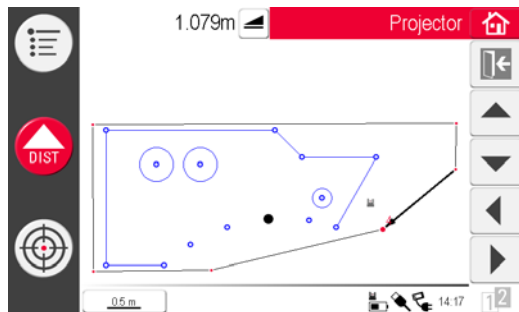

Porous, structured or rough surfaces cause problems if the laser beam cannot reflect off the exact position of the layout point.



You can also select points by tapping on a point on the screen or by using the Remote Control.

2. Laser point flashes if the exact position is found. Point is highlighted in red in sketch area.

To layout further points select another point and press .

3. Press  to go back to the **Aligner** tool.

4. Press  to save the file.

Plane Switching



If a point can not be projected on the ceiling, just move the laser beam onto the floor before pressing the **DIST** key. Following points will be projected on the floor from now on. The projection surface can be changed at any time.

7.5.2 Targeting and Layout with RM100 Remote Control

Description

The functionality of the RM100 Remote Control is the same as in the other applications. The RM100 Remote Control only works if the Control Unit is ON - otherwise measurement errors cannot be displayed and avoided.

Functionality of the keys in Projector application

Red key ●:

- Press ● to activate laser and a second time to project or measure a point within the reference area.

Short key press on ▲ / ▼ / ◀ / ▶:

- Each arrow key selects the neighbouring point, turns the 3D Disto and starts the iterative measurement. Press once to activate the remote control and a second time to execute the command.
-

8

Error Messages

Error messages and advice

Error no.	Advice
150	Working range was exceeded.
151	Invalid measurement.
152	Change 3D Disto's position or use ruler for offset points.
160	Repeat and do not move the ruler between both measurements.
161	In some cases the Offset Point tool can not be used.
170	Restart 3D Disto if the problem persists.
171	Check all devices, for example power supply or cables, and try again.
240	Tilt sensor calibration was not successful. System accuracy is at risk. Contact your distributor or Leica Geosystems representative.
241	Too much drift. Repeat calibration precisely.
243	Set up instrument stably. Do not touch or rotate the 3D Disto. Repeat calibration.
300	Select a horizontal line.
350	Check projection surface. Laser could not reach the correct position.

Error no.	Advice
755	Point cannot be measured. Try different position. Tool does not work on horizontal planes.
760	Point cannot be measured. Enter different values. Tool does not work on horizontal planes.
765	Point cannot be measured. Try different position or enter different value. Tool does not work on horizontal planes.
800	Data import or export is not possible.
801	Not enough memory on USB stick.
802	Storage device does not work properly.
803	Check file condition and content.
804	File or Folder write-protected or damaged.
900	3D Disto error. Contact your distributor or Leica Geosystems representative if the error repeats.
901	The reflected laser signal is too low.
902	The reflected laser signal is too high.
903	Too much background light.
904	Laser beam interrupted. Repeat measurement.

Error no.	Advice
950	Execute Location Check to retain accuracy!
951	3D Disto tilt is over 3°. Set up horizontally!
952	Check 3D Disto, check for obstacles interrupting WLAN connection, or move towards 3D Disto.
953	Check connection and cable.
954	Plug in cable or choose "WLAN" in the menu.
955	3D Disto temperature out of working range.
956	Too much vibration or permanent movement.
998	Contact your distributor or Leica Geosystems representative.
999	Contact your distributor or Leica Geosystems representative.

9 Check & Adjust

9.1 Overview

Description

Leica Geosystems instruments are manufactured, assembled and adjusted to the best possible quality and precision. Quick temperature changes, shock or stress can cause deviations and decrease the instrument accuracy. It is therefore recommended to check and adjust the instrument from time to time. This can be done on site by running through specific measurement procedures. The procedures are guided and have to be followed carefully and precisely as described in the following chapters.

Electronic adjustment

The following instrument errors can be checked and adjusted electronically:

- Crosshairs offset
- V-index
- Tilt sensor



All calibration settings can also be reset to factory default.

Every angle measured during daily work is corrected automatically if the tilt sensor is activated and the 3D Disto is set up between 0° and 3°.



During the manufacturing process, the instrument errors are carefully determined and set to zero. As mentioned previously, these errors can change and it is highly recommended to redetermine them in the following situations:

- After rough or long transportation
 - After long storage periods
 - If the temperature difference between the current environment and at the last calibration is more than 20°C
-

9.2

Crosshairs Offset

Problem

The laser point and the crosshairs in the Viewfinder do not coincide.

Before calibration:

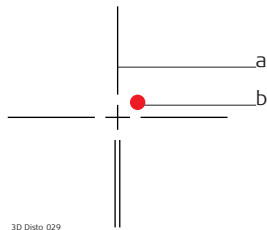

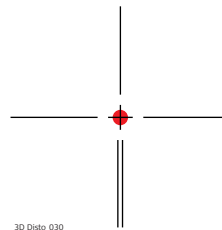

After calibration:



- a) Crosshairs
- b) Laser spot

Adjustment step-by-step

1. Calibration is started in **Menu » Device » Calibration**.
 2. Press .
 3. Viewfinder opens. Place a target mark at a distance > 25 m. Now aim at the target mark as precisely as possible. Press  when the red laser spot is exactly on the target.
 4. Viewfinder stays open and red crosshairs are displayed. Move crosshairs to the centre of target mark as precisely as possible with the arrow keys. Press  again.
 5. If in tolerance, pop-up appears with **Set new: x=...px; y=...px, Reset to factory default**, or **Cancel calibration**.
 6. Choose **Set...** or **Reset...** to adjust crosshairs. Final pop-up asks **Are you sure? Yes/Cancel**.
 7. If **Yes**, checkmark is displayed to confirm parameters were set successfully.
-

9.3

V-Index Error

Problem

The vertical index does not coincide with the standing axis. This can be detected when the heights or height differences of measured points appear incorrect, for example Tool Kit measurements do not work properly.



Tilt sensor calibration followed by crosshairs calibration is recommended before starting V-Index calibration! Refer to "9.4 Tilt Sensor Calibration" and "9.2 Crosshairs Offset".

Before calibration:

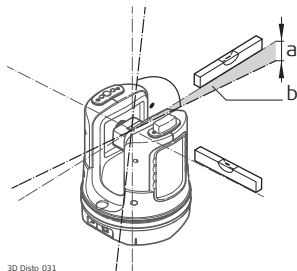

- a) Height error
- b) Vertical angle offset

After calibration:

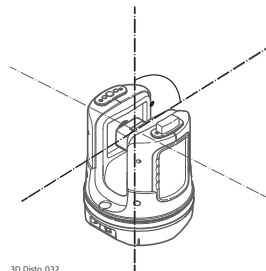

Adjustment step-by-step

1. Set up the 3D Disto close to a wall with a steep target of good visibility that is at least 15 m above the instrument.

2. Press .

3. Viewfinder opens. Target as precisely as possible.

Press .

4. 3D Disto turns to second face automatically.

5. Target a second time. Press .

6. If both measurements were successful, a pop-up appears with **Set new:**
XXX gon, Reset to factory default, or Cancel calibration.

7. Choose **Set...** or **Reset...** to adjust V-index. Final pop-up asks **Are you sure?**
Yes/Cancel.

8. If **Yes**, checkmark is displayed to confirm parameters were set successfully.

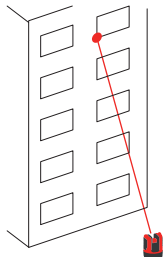

3D Disto_051

9.4 Tilt Sensor Calibration

Problem

A tilt sensor error has the same impact as the V-index error but is orientation-dependent.

This can be detected when the heights or height differences of measured points appear incorrect, for example **Go to Horizon** turn command or plumbing does not work properly.

Before calibration:

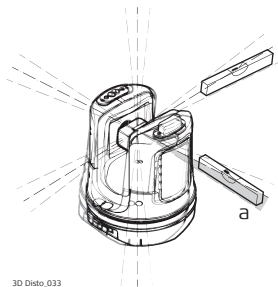

a) Tilt sensor offset

After calibration:

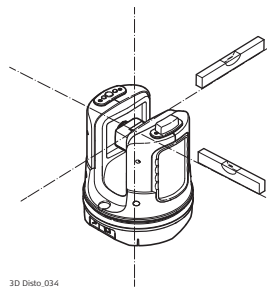



Adjustment step-by-step

This calibration is done automatically. You must only ensure that the 3D Disto is set up <math> < 3^\circ </math>.

1. Press .
 2. 3D Disto starts self-levelling automatically: the tilt is checked and the instrument levels itself if the tilt is <math> < 3^\circ </math>. Pop-up prompts **Don't touch 3D Disto about 1 minute!**
 3. If **ok**, pop-up prompts **Calibration successful.**
-

9.5

Reset to Factory Settings

Reset to factory settings step-by-step

1. Press .
 2. Pop-up appears **Reset all calibration settings to factory default? Yes/No.**
 3. If **Yes**: all user-defined calibration settings are reset to factory default without further request.
-

10 Instrument Protection (Theft Protection)

Description

The instrument can be protected by a **Personal Identification Number**. If the PIN protection is activated, the Control Unit will always prompt for a PIN code entry after starting up. If the wrong PIN was entered three times, a PUK is required, which can be found on the instrument delivery papers. If the PUK code was entered correctly, the PIN code is set to default value "0" and the PIN protection is deactivated. Contact your Leica Geosystems representative if you need a replacement PUK.

Activate PIN code step-by-step

1. Start-up Control Unit as described in "5 Instrument Setup".
2. Go to **Menu » Device » Theft Protection**. Default setting is **Off**.
3. Press **On** to activate.
4. Enter your desired PIN code (3 to 8 character numeric or alpha).
5. Accept with **Ok**.



Now the instrument is protected against unauthorised use. The PIN code is required now after switching on the instrument, de-activating standby, or re-entering the PIN settings.

Deactivate PIN code step-by-step

1. Start-up Control Unit as described in "5 Instrument Setup".
2. Go to **Menu » Device » Theft Protection**.
3. Enter your PIN code and press **OK** to accept.
4. Press **Off** to deactivate.



The instrument is no longer protected against unauthorised use.

11

Care and Transport

11.1

Transport

Transport in the field

When transporting the equipment in the field, always make sure that you

- either carry the product in its original transport container,
 - or carry the tripod with its legs splayed across your shoulder, keeping the attached product upright.
-

Transport in a road vehicle

Never carry the product loose in a road vehicle, as it can be affected by shock and vibration. Always carry the product in its transport container and secure it.

Shipping

When transporting the product by rail, air or sea, always use the complete original Leica Geosystems packaging, transport container and cardboard box, or its equivalent, to protect against shock and vibration.

Shipping, transport of batteries

When transporting or shipping batteries, the person in charge of the product must ensure that the applicable national and international rules and regulations are observed. Before transportation or shipping, contact your local passenger or freight transport company.

Field adjustment

After transport inspect the field adjustment parameters given in this user manual before using the product.

11.2**Storage**

Product

Respect the temperature limits when storing the equipment, particularly in summer if the equipment is inside a vehicle. Refer to "13 Technical Data" for information about temperature limits.

Field adjustment

After long periods of storage inspect the field adjustment parameters given in this user manual before using the product.

Batteries

- **Alkaline and Li-Ion batteries**
 - Refer to "13 Technical Data" for information about storage temperature range.
 - A storage temperature range of 0°C to +20°C / +32°F to +68°F in dry environment is recommended to minimise self-discharging of the battery.
 - At the recommended storage temperature range, batteries containing a 70% to 100% charge can be stored for up to one year. After this storage period the batteries must be recharged.
 - After storage recharge batteries (Li-Ion) before using.
 - Protect batteries from damp and wetness. Wet or damp batteries must be dried before storing or use.
-

11.3

Cleaning and Drying

Lens and housing of 3D Disto

- Blow dust off lens and housing.
 - Never touch the glass with your fingers.
 - Use only a clean, soft, lint-free cloth for cleaning. If necessary, moisten the cloth with water or pure alcohol. Do not use other liquids; these may attack the polymer components.
-

Damp products

- Dry the product, the transport container, the foam inserts and the accessories at a temperature not greater than 40°C / 104°F and clean them.
 - Do not repack until everything is completely dry.
 - Always close the transport container when using in the field.
-

Cables and plugs

Keep plugs clean and dry. Blow away any dirt lodged in the plugs of the connecting cables.

12 Safety Directions

12.1 General

Description

The following directions should enable the person responsible for the product, and the person who actually uses the equipment, to anticipate and avoid operational hazards.

The person responsible for the product must ensure that all users understand these directions and adhere to them.

12.2

Intended Use

Permitted use

- 3D measuring of distance, heights, grades, angles, area, and volume.
 - Manual and automatic measurement of room dimensions.
 - Automatic measurement of profiles.
 - Laying out points and designs, for example from blueprint.
 - Generation of drawings.
 - Camera functionality.
 - Import/Export of data.
 - Administration of data.
-

Adverse use

- Use of the product without instruction.
- Use outside of the intended limits.
- Disabling safety systems.
- Removal of hazard notices.
- Opening the product using tools, for example screwdriver, unless this is specifically permitted for certain functions.
- Modification or conversion of the product.
- Use of products with obviously recognisable damages or defects.
- Use with accessories from other manufacturers without the prior explicit approval of Leica Geosystems.
- Inadequate safeguards at the working site, for example when measuring on roads or sites.
- Deliberate dazzling of third parties.
- Controlling of machines, moving objects or similar monitoring application without additional control- and safety installations.



Adverse use can lead to injury, malfunction and damage.

It is the task of the person responsible for the equipment to inform the user about hazards and how to counteract them. The product is not to be operated until the user has been instructed on how to work with it.

12.3

Limits of Use

Environment

Suitable for use in an atmosphere appropriate for permanent human habitation: not suitable for use in aggressive or explosive environments.



Danger

Local safety authorities and safety experts must be contacted before working in hazardous areas, or in close proximity to electrical installations or similar situations by the person in charge of the product.

12.4

Responsibilities

Manufacturer of the product

Leica Geosystems AG, CH-9435 Heerbrugg, hereinafter referred to as Leica Geosystems, is responsible for supplying the product, including the user manual and original accessories, in a completely safe condition.

Manufacturers of non Leica Geosystems accessories

The manufacturers of non Leica Geosystems accessories for the product are responsible for developing, implementing and communicating safety concepts for their products, and are also responsible for the effectiveness of those safety concepts in combination with the Leica Geosystems product.

Person in charge of the product

The person in charge of the product has the following duties:

- To understand the safety instructions on the product and the instructions in the user manual.
- To be familiar with local regulations relating to safety and accident prevention.
- To inform Leica Geosystems immediately if the product and the application becomes unsafe.



The person responsible for the product must ensure that it is used in accordance with the instructions. This person is also accountable for the training and the deployment of personnel who use the product and for the safety of the equipment in use.

12.5

Hazards of Use

Warning

The absence of instruction, or the inadequate imparting of instruction, can lead to incorrect or adverse use, and can give rise to accidents with far-reaching human, material, financial and environmental consequences.

Precautions:

All users must follow the safety directions given by the manufacturer and the directions of the person responsible for the product.

Caution

Watch out for erroneous measurement results if the product has been dropped or has been misused, modified, stored for long periods or transported.

Precautions:



Periodically carry out test measurements and perform the field adjustments indicated in the user manual, particularly after the product has been subjected to abnormal use and before and after important measurements.

Warning

During dynamic applications, for example layout procedures there is a danger of accidents occurring if the user does not pay attention to the environmental conditions around, for example obstacles such as cables.

Precautions:

The person responsible for the product must make all users fully aware of the existing dangers.

-
-  **Warning** Inadequate securing of the working site can lead to dangerous situations, for example in traffic, on building sites, and at industrial installations.
Precautions:
Always ensure that the working site is adequately secured. Adhere to the regulations governing safety and accident prevention and road traffic.
-
-  **Caution** If the accessories used with the product are not properly secured and the product is subjected to mechanical shock, for example blows or falling, the product may be damaged or people may sustain injury.
Precautions:
When setting-up the product, make sure that the accessories are correctly adapted, fitted, secured, and locked in position.
Avoid subjecting the product to mechanical stress.
-
-  **Caution** During the transport, shipping or disposal of batteries it is possible for inappropriate mechanical influences to constitute a fire hazard.
Precautions:
Before shipping the product or disposing of it, discharge the batteries by running the product until they are flat.
When transporting or shipping batteries, the person in charge of the product must ensure that the applicable national and international rules and regulations are observed. Before transportation or shipping contact your local passenger or freight transport company.
-

 **Warning**

Using a battery charger not recommended by Leica Geosystems can destroy the batteries. This can cause fire or explosions.

Precautions:

Only use chargers recommended by Leica Geosystems to charge the batteries.

 **Warning**

High mechanical stress, high ambient temperatures or immersion into fluids can cause leakage, fire or explosions of the batteries.

Precautions:

Protect the batteries from mechanical influences and high ambient temperatures. Do not drop or immerse batteries into fluids.

 **Warning**

Flat batteries must not be disposed of with household waste. Care for the environment and take them to the collection points provided in accordance with national or local regulations.

If the product is improperly disposed of, the following can happen:

- If polymer parts are burnt, poisonous gases are produced which may impair health.
- If batteries are damaged or are heated strongly, they can explode and cause poisoning, burning, corrosion or environmental contamination.

- By disposing of the product irresponsibly you may enable unauthorised persons to use it in contravention of the regulations, exposing themselves and third parties to the risk of severe injury and rendering the environment liable to contamination.

Precautions:

The product must not be disposed with household waste.

Dispose of the product appropriately in accordance with the national regulations in force in your country.

Always prevent access to the product by unauthorised personnel.

Product specific treatment and waste management information can be downloaded from the Leica Geosystems home page at <http://www.leica-geosystems.com/treatment> or received from your Leica Geosystems dealer.



Only Leica Geosystems authorised service workshops are entitled to repair these products.

12.6

Laser Classification

Integrated distance metre

The Leica 3D Disto produces a visible laser beam which emerges from the front of the instrument.

It is a Class 2 laser product in accordance with:

- IEC60825-1: 2007 "Radiation safety of laser products"

Laser Class 2 products:

Do not stare into the laser beam or direct it towards other people unnecessarily. Eye protection is normally afforded by aversion responses including the blink reflex.

Warning

Looking directly into the beam with optical aids (e.g. binoculars, telescopes) can be hazardous.

Precautions:

Do not look directly into the beam with optical aids.

Caution

Looking into the laser beam may be hazardous to the eyes.

Precautions:

Do not look into the laser beam. Make sure the laser is aimed above or below eye level. (particularly with fixed installations, in machines, etc.)

Labelling

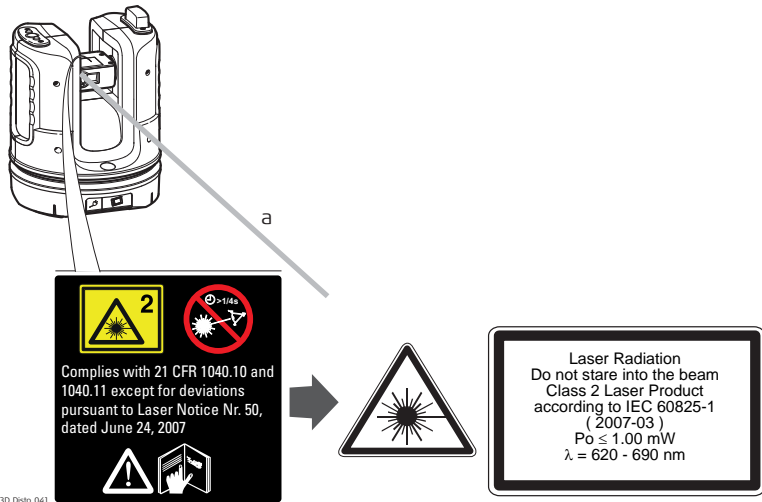

a) Laser beam

12.7

Electromagnetic Compatibility EMC

Description

The term Electromagnetic Compatibility is taken to mean the capability of the product to function smoothly in an environment where electromagnetic radiation and electrostatic discharges are present, and without causing electromagnetic disturbances to other equipment.



Warning

The 3D Disto conforms to the most stringent requirements of the relevant standards and regulations.

Yet, the possibility of it causing interference in other devices cannot be totally excluded.



Caution

Never attempt to repair the product yourself. In case of damage, contact the local dealership.



Warning

Electromagnetic radiation can cause disturbances in other equipment.

Although the product meets the strict regulations and standards which are in force in this respect, Leica Geosystems cannot completely exclude the possibility that other equipment may be disturbed.

 **Caution**

There is a risk that disturbances may be caused in other equipment if the product is used in conjunction with accessories from other manufacturers, for example field computers, personal computers, two-way radios, non-standard cables or external batteries.

Precautions:

Use only the equipment and accessories recommended by Leica Geosystems. When combined with the product, they meet the strict requirements stipulated by the guidelines and standards. When using computers and two-way radios, pay attention to the information about electromagnetic compatibility provided by the manufacturer.

 **Caution**

Disturbances caused by electromagnetic radiation can result in erroneous measurements.

Although the product meets the strict regulations and standards which are in force in this respect, Leica Geosystems cannot completely exclude the possibility that the product may be disturbed by very intense electromagnetic radiation, for example, near radio transmitters, two-way radios or diesel generators.

Precautions:

Check the plausibility of results obtained under these conditions.

 **Warning**

If the product is operated with connecting cables attached at only one of their two ends, for example external supply cables, interface cables, the permitted level of electromagnetic radiation may be exceeded and the correct functioning of other products may be impaired.

Precautions:

While the product is in use, connecting cables, for example product to external battery, product to computer, must be connected at both ends.

 **Warning**

Work with WLAN

Electromagnetic fields can cause disturbances in other equipment, in installations, in medical devices, for example pacemakers or hearing aids and in aircraft. It can also affect humans and animals.

Precautions:

Although the product meets in combination with radio or digital cellular phone devices recommended by Leica Geosystems the strict regulations and standards which are in force in this respect, Leica Geosystems cannot completely exclude the possibility that other equipment may be disturbed or that humans or animals may be affected.

- Do not operate the product in the vicinity of filling stations or chemical installations, or in other areas where an explosion hazard exists.
 - Do not use the product near medical to equipment.
 - Do not operate the product in aircraft.
 - Do not use the product near your body for extended periods.
-

12.8**FCC Statement, Applicable in U.S.**

 **Warning**

This equipment has been tested and found to comply with the limits for a Class B digital device, pursuant to part 15 of the FCC rules. These limits are designed to provide reasonable protection against harmful interference in a residential installation.

This equipment generates, uses and can radiate radio frequency energy and, if not installed and used in accordance with the instructions, may cause harmful interference to radio communications. However, there is no guarantee that interference will not occur in a particular installation.

If this equipment does cause harmful interference to radio or television reception, which can be determined by turning the equipment off and on, the user is encouraged to try to correct the interference by one or more of the following measures:

- Reorient or relocate the receiving antenna.
 - Increase the separation between the equipment and the receiver.
 - Connect the equipment into an outlet on a circuit different from that to which the receiver is connected.
 - Consult the dealer or an experienced radio/TV technician for help.
-

 **Warning**

Changes or modifications not expressly approved by Leica Geosystems for compliance could void the user's authority to operate the equipment.

SAR information

FCC Radiation Exposure Statement

The radiated output power of the instrument is far below the FCC radio frequency exposure limits. Nevertheless, the instrument should be used in such a manner that the potential for human contact during normal operation is minimised. To avoid the possibility of exceeding the FCC radio frequency exposure limits, you should keep a distance of at least 20 cm between you (or any other person in the vicinity) and the antenna that is built into the instrument.

Labelling 3D Disto

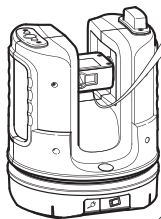

3D Disto_042

Equi.No.:

123456789012

S/N:

12345678

Type: Leica 3D Disto

Art.No.: 772171 Power: 24V \neq 2.5A
IC: 3177A-3DDISTO FCC ID: RFF-3DDISTO
Patents: WO 9427164, WO 0216964,
WO 03008909, WO 0244754, EP 1195617, WO 9818019

This device complies with part 15 of the FCC Rules. Operation is subject to the following two conditions:

- (1) This device may not cause harmful interference, and
- (2) this device must accept any interference received, including interference that may cause undesired operation.



Made in Singapore
www.leica-geosystems.com

Labelling Control Unit

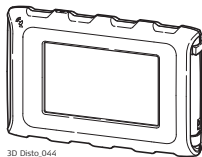

3D Disto_044

Art.No.: 123456



S.No.: PC102302494



Labelling RM100 Remote Control



3D Disto_043



Type: RM100

Art.No.: 780994

Power: 1.5V \leftrightarrow / 0.4A

Leica Geosystems AG

CH-9435 Heerbrugg

Manufactured:



12.9

Conformity to National Regulations

Conformity to National Regulations



Hereby, Leica Geosystems AG, declares that the instrument is in compliance with the essential requirements and other relevant provisions of applicable European Directives. The declaration of conformity may be consulted at <http://www.leica-geosystems.com/ce>.

- France
Concerning European Economic Area: The use of this WLAN product (or the WLAN function of this product) is restricted to only indoor use in France.
- Japan
This device has been granted a designation number by Ministry of Internal Affairs and Communications under „Ordinance concerning Technical Regulations Conformity Certification etc. of Specified Radio Equipment (特定無線設備の技術基準適合証明等に関する規則)“Article 2-1-xx “This device should not be modified (otherwise the granted designation number will be invalid)“

This equipment has the Type Approval Certification based on the Radio Law.
本機器は電波法に基づく工事設計認証を取得しています

- The conformity for countries with other national regulations not covered by the FCC part 15 or European directive 1999/5/EC has to be approved prior to use and operation.
-

13 Technical Data

Accuracy tie distance (3D)

	@ 10 m	@ 30 m	@ 50 m
Combination of angle and distance measurement	ca. 1 mm	ca. 2 mm	ca. 4 mm

Angle measurement (Hz/V)

Working range:	Horizontal 360°, Vertical 250°
Accuracy:	5" (1.2 mm @ 50 m)

Characteristics laser distance metre

Measuring system:	System analyser basis 100 MHz - 150 MHz
Type:	Coaxial, visible red laser
Working range:	0.5 - 50 m
Laser class:	2
Laser type:	650 nm; < 1 mW
Laser point size (at distances):	@ 10 m: ~7 mm x 7 mm @ 30 m: ~9 mm x 15 mm

Tilt sensor

Self-levelling range:	± 3°
Accuracy:	10" (2.5 mm @ 50 m)

Viewfinder

Zoom (Magnification):	1x, 2x, 4x, 8x
Field of view (@ 10 m):	1x: 3.40 m x 2.14 m
	2x: 1.70 m x 1.07 m
	4x: 0.85 m x 0.54 m
	8x: 0.42 m x 0.27 m

Circular bubble sensitivity

1°/mm

Operation

Type	Description
Display	High-resolution screen, 800 x 480 Pixel, 4.8" TFT LCD, 16 mil colour
Buttons/User interface	3D Disto: ON/OFF button Control Unit: Touchscreen, ON/OFF button
Memory capacity	Flash memory: 32 GB
Ports	3D Disto: USB Type B, power supply plug-in, power supply plug-in for Control Unit Control Unit: USB Type A, Micro-B, power supply plug-in

Communication

Type	Description
Data transfer	USB: Type Micro-B and Type A, WLAN
Wireless technology	SD Card, range 50 m (depending on the environment), 11 channels
Supported data formats	Import: DXF, CSV Export: DXF, TXT, CSV, JPG

Power

Instrument	Type	Typical operating time
3D Disto	Li-Ion battery, voltage: 14.4 V 63 Wh, charging time 8 h External power supply voltage: 24 VDC, 2.5 A	8 h
Control Unit	Li-Ion battery, 2500 mAh, 3.7 V External power supply voltage: 5 VDC, 2.0 A, charging time 7 h	6 h

Mounting

5/8" thread

Instrument dimensions

3D Disto: 186.6 x 215.5 mm (diameter x height)
Control Unit: 178.5 x 120 x 25.8 mm

Weight

3D Disto: 2.8 kg
Control Unit: 0.33 kg

Environmental specifications**Temperature**

Type	Operating temperature [°C]	Storage temperature [°C]
3D Disto	-10 to +50	-25 to +70
Control Unit	-10 to +50	-25 to +70

Protection against dust, sand and water

Type	Protection
3D Disto	IP54 (IEC 60529)
Control Unit	IP5X

Humidity

Type	Protection
3D Disto	Max. 85 % r.h non condensing
Control Unit	Max. 85 % r.h non condensing

**RM100 Remote
Control**

Range:	25 m (depending on environment and operation conditions)
Communication:	Infrared (IR)
Battery	1 AA, 1.5 V

14 International Limited Warranty, Software License Agreement

International Limited Warranty

This product is subject to the terms and conditions set out in the International Limited Warranty which you can download from the Leica Geosystems home page at <http://www.leica-geosystems.com/internationalwarranty> or collect from your Leica Geosystems distributor. The foregoing warranty is exclusive and is in lieu of all other warranties, terms or conditions, express or implied, either in fact or by operation of law, statutory or otherwise, including warranties, terms or conditions of merchantability, fitness for a particular purpose, satisfactory quality and non-infringement, all of which are expressly disclaimed.



The 3D Disto comes with a three* year warranty from Leica Geosystems.

More detailed information can be found at:

<https://myworld.leica-geosystems.com>

All rights reserved for changes (drawings, descriptions and technical specifications).

- * To receive the three year warranty, the 3D Disto must be registered on our website <https://myworld.leica-geosystems.com> within eight weeks of the purchase date. If the product is not registered, a two year warranty applies.
-

Software License Agreement

This product contains software that is preinstalled on the product, or that is supplied to you on a data carrier medium, or that can be downloaded by you online pursuant to prior authorisation from Leica Geosystems. Such software is protected by copyright and other laws and its use is defined and regulated by the Leica Geosystems Software License Agreement, which covers aspects such as, but not limited to, Scope of the License, Warranty, Intellectual Property Rights, Limitation of Liability, Exclusion of other Assurances, Governing Law and Place of Jurisdiction. Please make sure, that at any time you fully comply with the terms and conditions of the Leica Geosystems Software License Agreement.

Such agreement is provided together with all products and can also be referred to and downloaded at the Leica Geosystems home page at <http://www.leica-geosystems.com/swlicense> or collected from your Leica Geosystems distributor.

You must not install or use the software unless you have read and accepted the terms and conditions of the Leica Geosystems Software License Agreement. Installation or use of the software or any part thereof, is deemed to be an acceptance of all the terms and conditions of such License Agreement. If you do not agree to all or some of the terms of such License Agreement, you may not download, install or use the software and you must return the unused software together with its accompanying documentation and the purchase receipt to the dealer from whom you purchased the product within ten (10) days of purchase to obtain a full refund of the purchase price.

GNU public license

Parts of the 3D Disto software are developed under GPL (GNU public license). The corresponding licenses can be found on the 3D Disto documentation CD in the directory GPL licenses. For obtaining more information, please search for contact at www.leica-geosystems.com.

Index

A

Abbreviations	14
Absolute height	115
Addition	
After measurement	99
During measurement	100
Adjustment	
Crosshairs offset	174
Electronic	171
V-Index error	176
Aligner	163
Alignment	164
Angle	
Horizontal	14
Vertical	15
Application	
Application programs	40
Demo mode	41
Licensing and activation	42
Area	17, 102
Horizontal	103

Tilted	105
Assistant	70
Automated Scans	149

B

Battery	
Charging	59
First-time use	58
Brightness	89

C

Cable	28, 31, 36, 38
Calculator	83
Calibration	25, 173, 175, 177
Care	182
Check & adjust	171
Circle tool	134
Circular bubble	30
Cleaning and drying	184
Comfort levelling	113
Comfort plumbing	109
Comfort targeting	111

Components		User Manual	11
3D Disto	30	Drawing	97
Control Unit	34	DXF	25
RM100 Remote Control	35	E	
Configuration	67	Electromagnetic compatibility	196
Container contents	28	Electronic adjustment	171
Control Unit	29	Environmental specifications	208
Components	34	Error messages	168
Data export	80	Export	70, 80
Data import	76	Export files	82
Power supply	37	F	
User input	47	Factory settings	179
Coordinates	23	FCC Statement	199
Crosshairs	21, 86	Field of view	206
D		Files	73, 76
Data CD	28	Folder	72, 123
Data transfer	68, 76	G	
Date	61, 70	Gallery	75, 125
Decimal separator	61	Grid	25, 159
Demo mode	41	H	
Distance	16	Hand strap	34
Distance measurement	57		
Documentation	11		

Hazards of use	190	Laser	
Hidden point	26, 89	Classification	194
Horizon	17, 90	Laser distance metre	25, 30
Horizontal angle	14	LED	32, 35
Horizontal area	17, 102, 103	License key	40, 68
Horizontal distance	16	Limits of use	188
Horizontal volumes	103	Line drawing	97
How to use this manual	10	Line of sight	14
I		Location	106
Icon	53, 66, 73	M	
Import	70, 76	Magnification	53, 89
Infrared (IR) interface	30	Manual	
Intended use	186	Description of manuals	11
Interface	30, 47	How to use	10
K		Validity of user manual	10
Keys	49, 72, 167	Mass storage device	79, 81
L		Measurement	24, 51, 85, 91, 128
Labelling		Menu	49, 67
3D Disto	201	O	
Control Unit	202	Offset tools	89
RM100 Remote Control	202	Operating temperature	208
Language	61, 70		

P

Parallel line	118
PC	42, 45, 62, 77, 80
Perpendicular distance	16
Photos	71
Plumb up	17
Plumbing	107, 109
Polygon	52, 94
Pop-up	40, 65
Power supply	
3D Disto	36
Control Unit	37
RM100 Remote Control	39
Program	40
Projection	25
Projector	106, 159, 160

Q

Quick Start	11
-------------------	----

R

Rectangle tool	136
Redo	52
Reference axis	19
Reference height	18, 114, 126

Reference line	19, 118
Reference point	18
Relocation	122
Remote	27, 35, 57, 167
Reset	40, 70, 171
Responsibilities	189
Restart	40
Results	48
Results window	48, 54
Room Scan	55, 106, 126
Ruler for offset points	26

S

Safety directions	185
Safety Manual	11
Scale	50, 53
Scanning	149
Scans	149
Screen	48
Secure Points	22, 74, 120
Selection	97
Self-levelling	32, 60
Serial number	2
Settings	69, 179

Setup	58	Theft protection	180
Sketch area	48	Tie distance	16, 99
Slopes	91, 127	Tilt	20, 32, 60
Snap Radius	70	Tilt sensor	20
Software	40, 68, 106	Tilted area	17, 102
Standing axis	14	Tilting axis	14
Start-up	58	Time	61, 70
Status bar	48, 53, 66	Title bar	48
Storage	183	Tool Kit	56, 107
Storage temperature	208	Toolbar	48, 52, 87
Subtraction		Tools	106
After measurement	99	Trademarks	3
During measurement	100	Transport	182
Sum	99	Tripod clamp	34
Symbols	3, 53, 54, 55, 56	Turn commands	90
T		U	
Target marks	22, 28, 120	Undo	52
Targeting	57, 85, 88, 110	Unfold mode	130
Technical data	205	Units	61, 70
Technical terms	14	USB connection	28
Temperature	208	USB Stick	28, 79, 81
Instrument		User interface	47
Operating	208		

V

Vertical distance	16
Viewfinder	21, 48, 51, 87
Volume	102

W

Warranty	210
Weight	208
WLAN	28

Z

Zoom	50, 89
------------	--------

Patents:

WO 9427164
WO 0216964
US 5949531
WO 0244754
EP 1195617
WO 9818019

Leica Geosystems AG

Heinrich-Wild-Strasse
CH-9435 Heerbrugg
Switzerland
Phone +41 71 727 31 31

www.leica-geosystems.com

- when it has to be **right**

Leica
Geosystems

781129(CD)-3.0.0en
Original text
© 2014 Leica Geosystems AG, Heerbrugg, Switzerland