



2.00 by 2.25mm
 (.079 by .089") Pitch
 VHDM® and VHDM-HSD™

VHDM Series

74030	6 row Daughtercard Assembly
74040	8 row Daughtercard Assembly
74074	6 row Backplane Assembly
74075	8 row Backplane Assembly
74600	6 row Right Angle Male Assembly
74057	6 row Backplane Assembly (open)
74058	6 row Backplane Assembly (guide left)
74059	6 row Backplane Assembly (guide right)
74060	8 row Backplane Assembly (open)
74061	8 row Backplane Assembly (guide left)
74062	8 row Backplane Assembly (guide right)

**Daughtercard and Backplane
Series Numbers**

HDM Series

73670	6 row Daughtercard Assembly
73650	6 row Backplanes Assembly

HDM Standard Backplane Series

73642	73643	73644	73656(pwr)	76959
73797	73799	73800	73801	73802
73809	73810	73942	73943	73944
74301				

HDM Stacker

Receptacles

Power

73780	73998
74300	









Headers

73769	73781	73787
73770	73782	74428
73771	73783	

VHDM-HSD Series

74680	8 row Daughtercard Assembly
74686	8 row Hybrid Daughtercard Assembly
74670	5 row Daughtercard Assembly
74880	6 row Daughtercard Assembly
74886	6 row Hybrid Daughtercard Assembly
74649	8 row Standard Backplane (open)
74650	8 row Standard Backplane (guide left)
74651	8 row Standard Backplane (guide right)
74695	5 row Standard Backplane (open)
74696	5 row Standard Backplane (guide left)
74697	5 row Standard Backplane (guide right)
74979	6 row Standard Backplane (open)

20 19 18 17 16 15 14 13 12 11 10 9 8 7 6 5 4 3 2 1

MATERIAL NUMBER PCB THICKNESS >4.0 - 9.0 mm	MATERIAL NUMBER PCB THICKNESS 1.8 - 4.0 mm	BUSHING KEYING POSITION
74958-6901	74958-6001	A 
74958-6902	74958-6002	B 
74958-6903	74958-6003	C 
74958-6904	74958-6004	D 
74958-6905	74958-6005	E 
74958-6906	74958-6006	F 
74958-6907	74958-6007	G 
74958-6908	74958-6008	H 

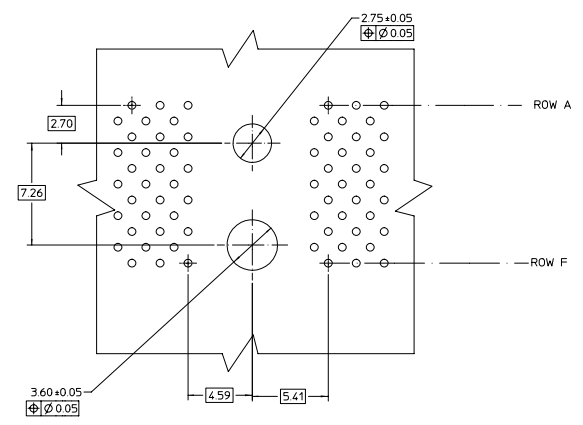
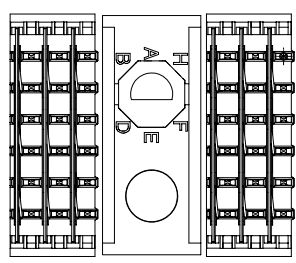

BILL OF MATERIAL FOR 74958-60**

ITEM	DESCRIPTION	QTY
1	GUIDE PIN	1
2	GUIDANCE & POLARIZING MODULE HOUSING	1
3	KEYING PIN	1
4	SCREW & WASHER (PCB 1.8-4.0mm)	1

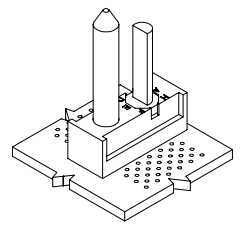
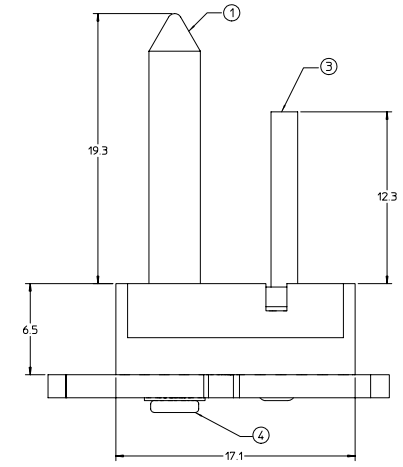
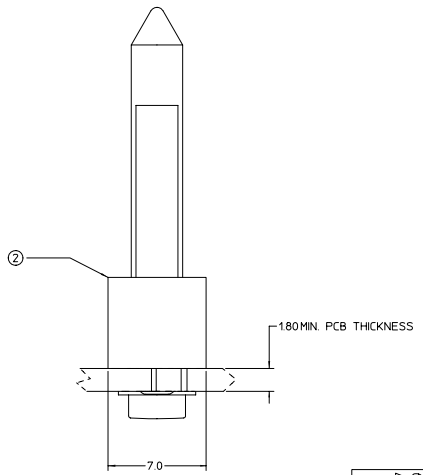









BILL OF MATERIAL FOR 74958-69**

ITEM	DESCRIPTION	QTY
1	GUIDE PIN	1
2	GUIDANCE & POLARIZING MODULE HOUSING	1
3	KEYING PIN	1
4	SCREW & WASHER (PCB >4.0-9.0mm)	1

- NOTES:
- MATERIAL:
HOUSING: LIQUID CRYSTAL POLYMER (LCP),
COLOR : BLACK
GUIDE PIN / KEYING PIN: STAINLESS STEEL
 - THIS PART CONFORMS TO MOLEX SPECIFICATION
PS-74031-999
 - PACKAGING : STANDARD BULK PACK, 100 PER BAG
PACKAGE SCREW SEPARATELY.

EC NO. LDT2002-0396 DRWN. MOSLEY 2001/12/17 CHKD. SREED 2001/12/19 APPR. CBIXLER 2001/12/20 REV DESCRIPTION	QUALITY SYMBOLS	GENERAL TOLERANCES (UNLESS SPECIFIED)	SCALE 6:1	DESIGN UNITS METRIC	THIRD ANGLE PROJECTION	REVISE ON CAD ONLY	
	4 PLACES ± --- ± --- 3 PLACES ± --- ± --- 2 PLACES ± --- ± --- 1 PLACE ± --- ± ---	mm INCH	DIMENSION STYLE	TITLE			
		MM ONLY	VHDM BACKPLANE GUIDANCE AND POLARIZING MODULE 6 ROW SALES DRAWING				
	DRAFT WHERE APPLICABLE MUST REMAIN WITHIN DIMENSIONS	ANGULAR ± 2 °	DRAWN BY NMARTIN CHECKED BY JLAURX APPROVED BY CBIXLER	DATE 01/09/05 DATE 01/09/05 DATE 01/09/05	MOLEX INCORPORATED MATERIAL NO. SEE CHART DOCUMENT NO. SD-74958-002 SHEET NO. 1 OF 1		

20 19 18 17 16 15 14 13 12 11 10 9 8 7 6 5 4 3 2 1

MATERIAL NUMBER PCB THICKNESS > 4.0 - 9.0	MATERIAL NUMBER PCB THICKNESS 18 - 4.0	BUSHING CLOCK POSITION
74959-8901	74959-8001	A 
74959-8902	74959-8002	B 
74959-8903	74959-8003	C 
74959-8904	74959-8004	D 
74959-8905	74959-8005	E 
74959-8906	74959-8006	F 
74959-8907	74959-8007	G 
74959-8908	74959-8008	H 

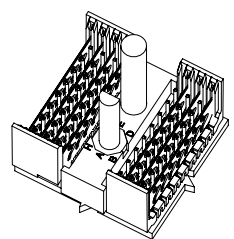
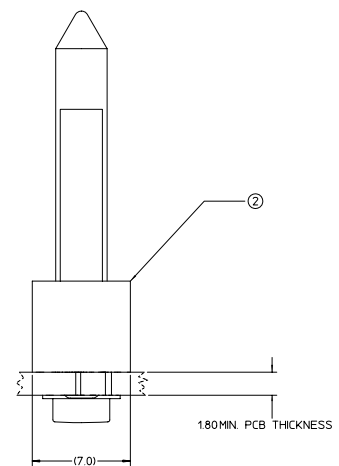
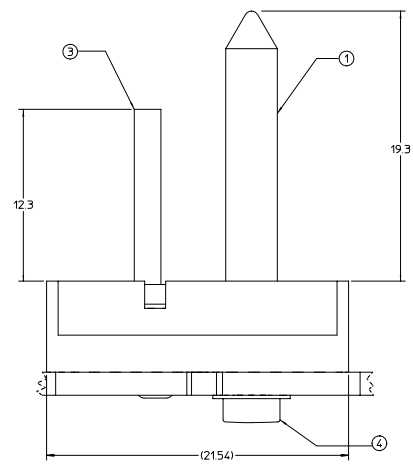
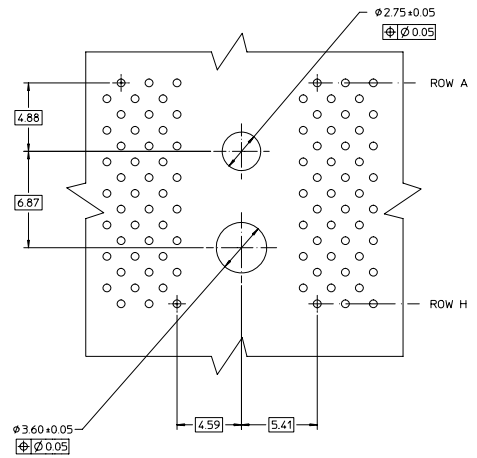
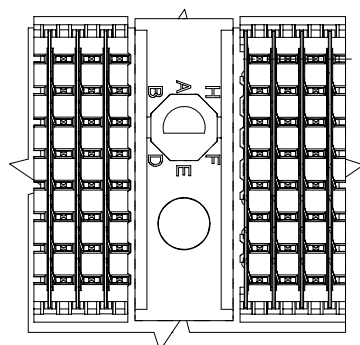

BILL OF MATERIAL 74959-8***

ITEM	DESCRIPTION	QTY.
1	GUIDE PIN	1
2	GUIDANCE & POLARIZING MODULE	1
3	KEYING PIN	1
4	SCREW & WASHER (PCB 18-4.0)	1







BILL OF MATERIAL 74959-89**

ITEM	DESCRIPTION	QTY.
1	GUIDE PIN	1
2	GUIDANCE & POLARIZING MODULE	1
3	KEYING PIN	1
4	SCREW & WASHER (PCB >4.0-9.0)	1

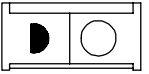
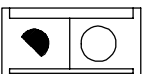
- NOTES:
- 1 MATERIAL: LIQUID CRYSTAL POLYMER (LCP).
COLOR : BLACK
 - 2 THIS PART CONFORMS TO MOLEX SPECIFICATION
PS-74031-999
 - 3 PACKAGING : STANDARD BULK PACK, 100 PER BAG
PACKAGE SCREW SEPARATELY.

EC NO. LDT2002-0414 DRWN: LMSLEY 2002/03/05 CHKD: MOWANG 2002/03/05 APPR: CBIXLER 2002/03/06	QUALITY SYMBOLS ▽-0 ▽-0	GENERAL TOLERANCES (UNLESS SPECIFIED)		SCALE 6:1	DESIGN UNITS METRIC	THIRD ANGLE PROJECTION	REVISE ON CAD ONLY		
		4 PLACES ±	3 PLACES ±	2 PLACES ±	1 PLACE ±	DIMENSION STYLE MM ONLY			
		mm	INCH	DRAWN BY NMARTIN			DATE 01/12/10	TITLE BACKPLANE GUIDANCE AND POLARIZING MODULE 8 ROW SALES DRAWING	
		ANGULAR ± 2 °		CHECKED BY JLAURX			DATE 01/12/10	MOLEX MOLEX INCORPORATED	
DRAFT WHERE APPLICABLE MUST REMAIN WITHIN DIMENSIONS		APPROVED BY CBIXLER			DATE 01/12/10	MATERIAL NO. SEE CHART	DOCUMENT NO. SD-74959-002	SHEET NO. 1 OF 1	
THIS DRAWING CONTAINS INFORMATION THAT IS PROPRIETARY TO MOLEX INCORPORATED AND SHOULD NOT BE USED WITHOUT WRITTEN PERMISSION									

1b_frame_D rev B 2000/06/12 19 18 17 16 15 14 13 12 11 10 9 8 7 6 5 4 3 2 1

PART NUMBER	KEY POSITION
75088-5001	A 
75088-5002	B 
75088-5003	C 
75088-5004	D 
75088-5005	E 
75088-5006	F 
75088-5007	G 
75088-5008	H 

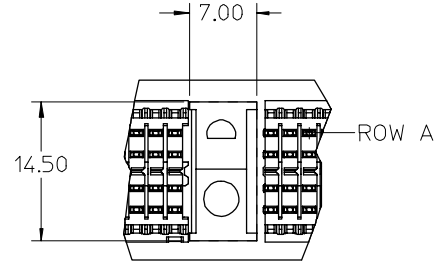

ADJACENT SIGNAL MODULES

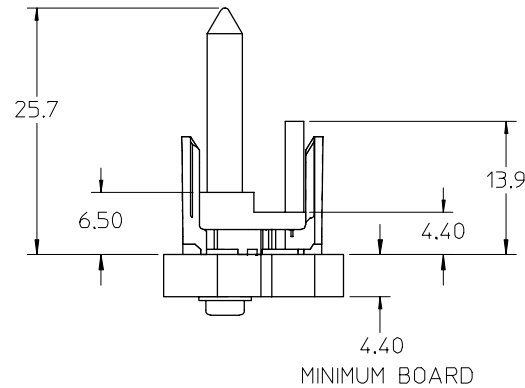
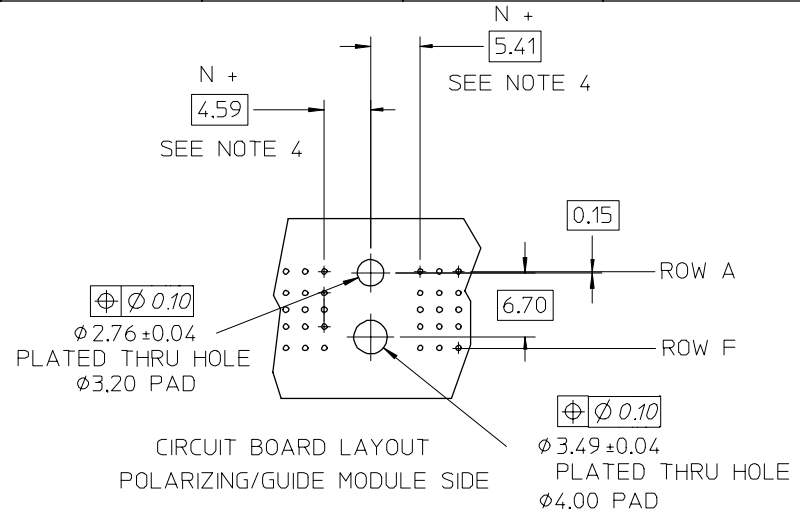
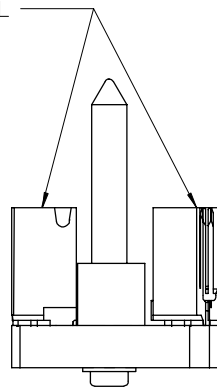

- NOTES:
 1. MATERIAL:
 ZINC ALLOY
 2. THIS PART CONFORMS TO MOLEX
 PRODUCT SPECIFICATION PS-74031-999
 3. PACKAGING:
 STANDARD BULK PACK, 100 PER BAG
 SCREWS PACKAGED SEPARATELY
 4. "N" MUST BE 0 OR A MULTIPLE OF 2.00

BILL OF MATERIAL 75088-500*

ITEM	DESCRIPTION	QTY.
1	GUIDANCE AND POLARIZING MODULE	1
2	SCREW AND WASHER (PCB >4.4 - 9.0)	1

EC NO: UCP2003-1409 DRWN:NMARTIN 2002/12/19 CHKD:JLAURX 2002/12/19 APPR:CBIXLER 2002/12/20	QUALITY SYMBOLS ▽ = 0 ▽ = 0	GENERAL TOLERANCES (UNLESS SPECIFIED)		SCALE 2:1	DESIGN UNITS METRIC	THIRD ANGLE PROJECTION	REVISE ON CAD ONLY	
				DIMENSION STYLE MM ONLY		TITLE VHDM 5 ROW HSD BACKPLANE POLAR/GUIDE MODULE SALES ASSEMBLY		
		4 PLACES ± --- ± ---		DRAWN BY DATE JBINGHAM 02/02/13		MATERIAL NO. DOCUMENT NO. SHEET NO. SEE CHART SD-75088-002 1 OF 1		
		3 PLACES ± --- ± ---		CHECKED BY DATE NMARTIN 02/02/13		MATERIAL NO. DOCUMENT NO. SHEET NO. SEE CHART SD-75088-002 1 OF 1		
2 PLACES ± --- ± ---		APPROVED BY DATE CBIXLER 02/02/13		THIS DRAWING CONTAINS INFORMATION THAT IS PROPRIETARY TO MOLEX INCORPORATED AND SHOULD NOT BE USED WITHOUT WRITTEN PERMISSION				
1 PLACE ± --- ± ---		ANGULAR ± --- °						
DRAFT WHERE APPLICABLE		MUST REMAIN WITHIN DIMENSIONS						

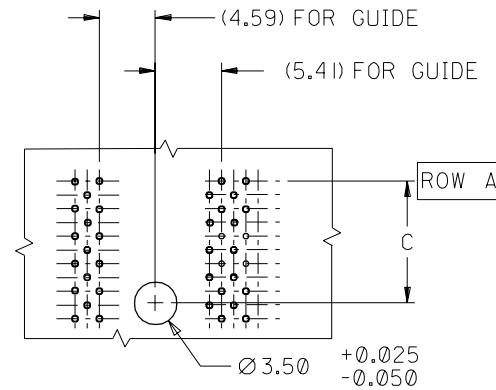
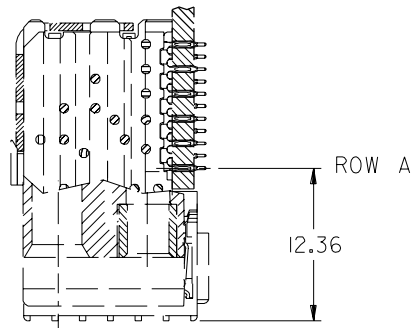
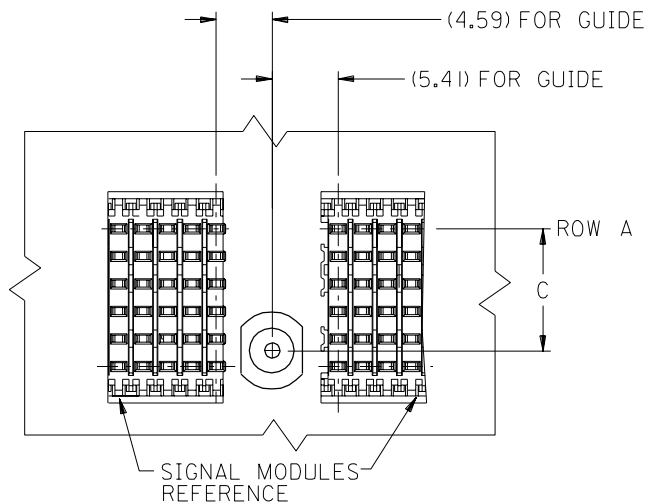

BACKPLANE HOLE PATTERN
FREE STAND GUIDE PIN

KIT NUMBER	Z(MM) BOARD THICKNESS
74076-0001	1.8-4.0
74076-0002	>4.0-9.00

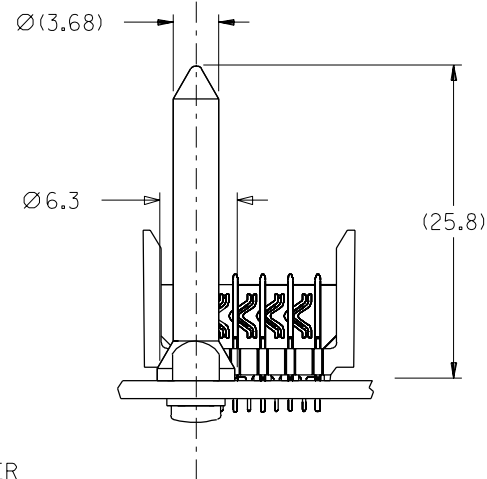
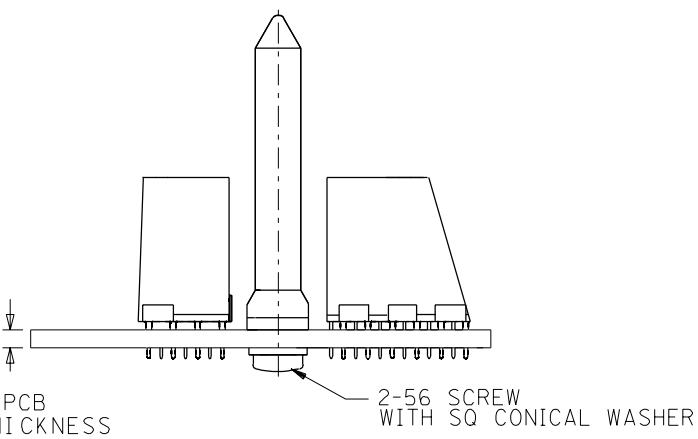

NOTES:
PACKAGING: STANDARD BULK PACK, 500 PER BAG
PACKAGE SCREWS AND GUIDE SEPARATE.

MATE WITH		DIM C
VHDM 6 ROW	GUIDE MODULE	9.96
	GROUND MODULE	9.26
	JOINER MODULE	9.26
VHDM 8 ROW	GUIDE MODULE	11.75
	GROUND MODULE	11.75
	JOINER MODULE	11.75

REVISED EC NO. UDT2001-0045 DRWG: MWANG 00/07/14 CHK: JLAURX 00/07/14 APPR: CBIXLER 00/07/14	QUALITY SYMBOLS MAJOR CRITICAL	GENERAL TOLERANCES: (UNLESS SPECIFIED)		SCALE	DESIGN UNITS <input checked="" type="checkbox"/> mm <input type="checkbox"/> INCH	DIMENSIONS: <input type="checkbox"/> mm <input type="checkbox"/> INCH <input checked="" type="checkbox"/> mm ONLY	SHT REV		
		4 PLACES ±0. -- ±.	3 PLACES ±0. -- ±.	2 PLACES ±0. 10 ±.	1 PLACE ±0. 15 ±.	DRAWN BY & DATE MWANG 00/03/17	CHECKED BY & DATE JLAURX 00/03/20	APPROVED BY & DATE CBIXLER 00/03/20	TITLE: VHDM BACKPLANE FREE STANDING GUIDE PIN SALES DRAWING
		ANGULAR: ± 3°				CAD FILENAME SD-74076-002.DGN	MATERIAL NO. SEE TABLE	DRAWING NO. SD-74076-002	SHEET NO. 1 OF 1
		DRAFT WHERE APPLICABLE MUST REMAIN WITHIN DIMENSIONS				THIS DRAWING CONTAINS INFORMATION THAT IS PROPRIETARY TO MOLEX INCORPORATED AND SHOULD NOT BE USED WITHOUT WRITTEN PERMISSION.			

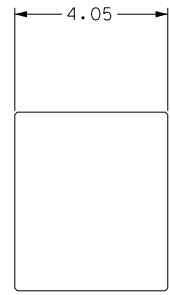
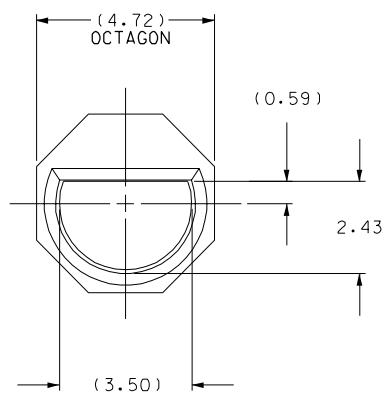

NOTES:

1. MATERIAL: STAINLESS STEEL.
2. FINISH: PASSIVATE.
3. PRODUCT SPECIFICATION: PS-74031-999.
4. PACKAGING SPECIFICATION: BULK PACK IN PLASTIC BAG, 100 PARTS PER BAG.
5. CONSULT FACTORY FOR INSTALLATION DETAILS.

INITIAL RELEASE EC NO. J0120001-1234 DRWN: MWANG 01/05/15 CHK: JL AURX 01/05/15 APPR: CBIXLER 01/05/16	DESCRIPTION REV	QUALITY SYMBOLS MAJOR = 0 CRITICAL = 0	GENERAL TOLERANCES: (UNLESS SPECIFIED)	SCALE 10:1 DESIGN UNITS <input checked="" type="checkbox"/> mm <input type="checkbox"/> INCH	DIMENSIONS: <input type="checkbox"/> mm <input type="checkbox"/> INCH <input checked="" type="checkbox"/> mm ONLY	SHT REV
		DRAWN BY & DATE MWANG 01/05/15	CHECKED BY & DATE JL AURX 01/05/15	THIRD ANGLE PROJECTION	TITLE: VHM & HDM DAUGHTER CARD OPTION ACCEPTOR KEY SALES DRAWING	REVISE ON CAD ONLY
		APPROVED BY & DATE CBIXLER 01/05/15	CAD FILENAME SD-73661-002.DGN	MATERIAL NO. 73661-0000	DRAWING NO. SD-73661-002	SHEET NO. 1 OF 1
		ANGULAR: ± 2°	DRAFT WHERE APPLICABLE MUST REMAIN WITHIN DIMENSIONS	THIS DRAWING CONTAINS INFORMATION THAT IS PROPRIETARY TO MOLEX INCORPORATED AND SHOULD NOT BE USED WITHOUT WRITTEN PERMISSION.	MOLEX INCORPORATED	SIZE C

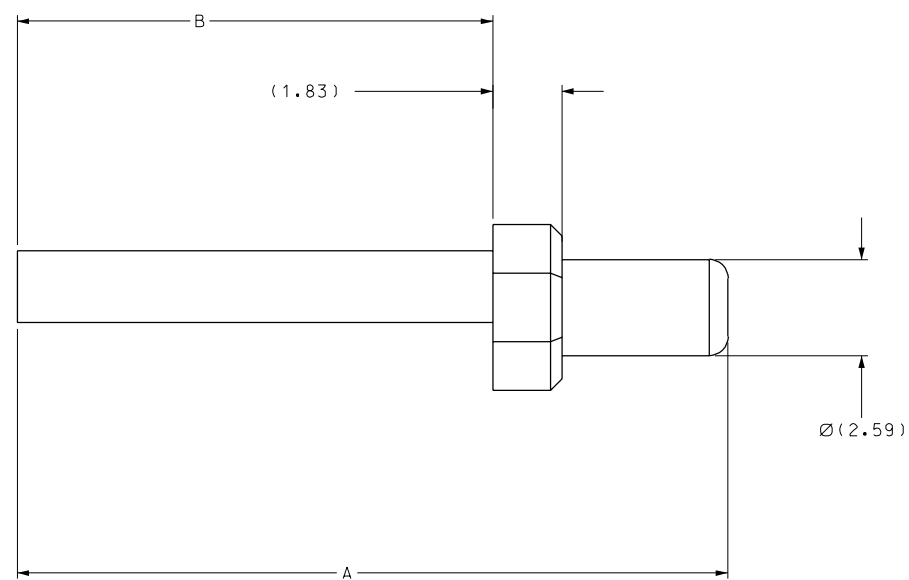
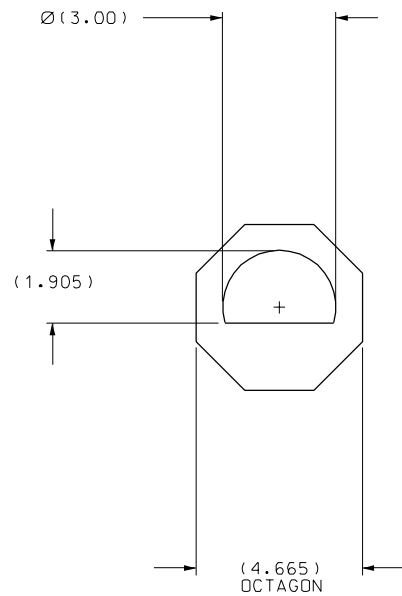
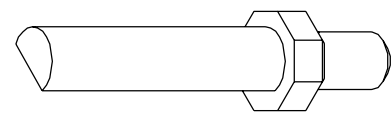

NOTES:

1. MATERIAL: STAINLESS STEEL CL303 OR 303.
2. FINISH: PASSIVATE.
3. PRODUCT SPECIFICATION: PS-74031-999.
4. PACKAGING SPECIFICATION: BULK PACK IN PLASTIC BAG, 100 PARTS PER BAG.
5. CONSULT FACTORY FOR INSTALLATION DETAILS.

P/N	A	B
74069-0010	18.8	12.58
74069-0030	14.6	10.47

INITIAL RELEASE EC NO. J012001-1294 DRWN: MWANG 01/05/15 CHK: JLAURX 01/05/15 APPR: CBIXLER 01/05/16	DESCRIPTION REV	QUALITY SYMBOLS MAJOR = 0 CRITICAL = 0	GENERAL TOLERANCES: (UNLESS SPECIFIED)	SCALE 10:1	DESIGN UNITS <input checked="" type="checkbox"/> mm <input type="checkbox"/> INCH	DIMENSIONS: <input type="checkbox"/> mm <input type="checkbox"/> INCH <input checked="" type="checkbox"/> mm ONLY	SHT REV	
		DRAWN BY & DATE MWANG 01/05/15	CHECKED BY & DATE JLAURX 01/05/15	APPROVED BY & DATE CBIXLER 01/05/15	CAD FILENAME SD-74069-002.DGN	MATERIAL NO. SEE TABLE	DRAWING NO. SD-74069-002	SHEET NO. 1 OF 1
		TITLE: VHDM & HSD BACKPLANE KEYING PIN SALES DRAWING			MOLEX INCORPORATED			THIS DRAWING CONTAINS INFORMATION THAT IS PROPRIETARY TO MOLEX INCORPORATED AND SHOULD NOT BE USED WITHOUT WRITTEN PERMISSION.
		DRAFT WHERE APPLICABLE MUST REMAIN WITHIN DIMENSIONS			THIS DRAWING CONTAINS INFORMATION THAT IS PROPRIETARY TO MOLEX INCORPORATED AND SHOULD NOT BE USED WITHOUT WRITTEN PERMISSION.			SIZE C

VHDM 6 ROW
LENGTHWISE (X) GATHERING

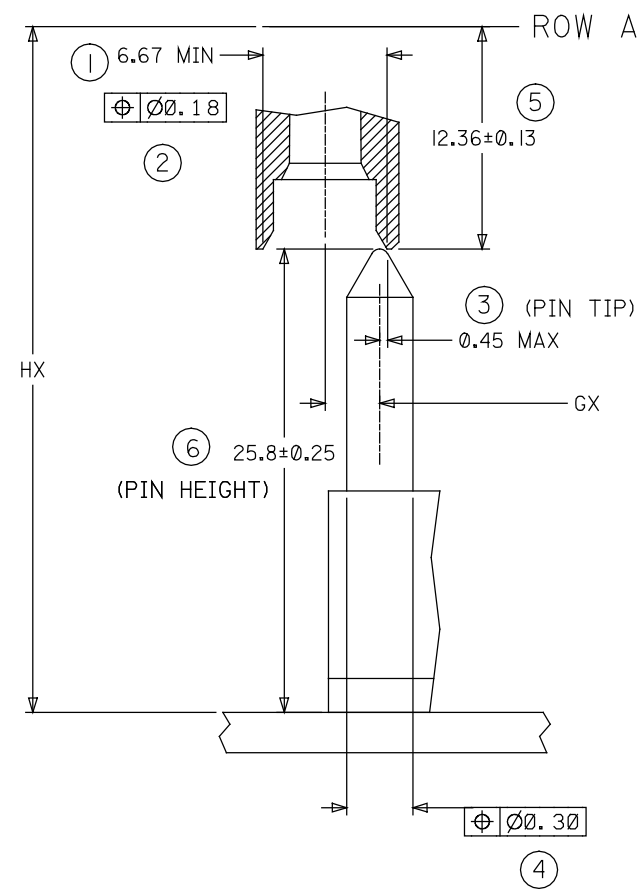

GATHERING:	
3.33	① × 0.5
-0.09	②
-0.45	③
-0.15	④
<hr/>	
GX = 2.64 (WORST CASE)	
ROW A HEIGHT AT GATHERING:	
12.36±0.13	⑤
+ 25.8±0.25	⑥
<hr/>	
HX = 38.16±0.38	

VHDM 6 ROW
WIDTHWISE (Y) GATHERING

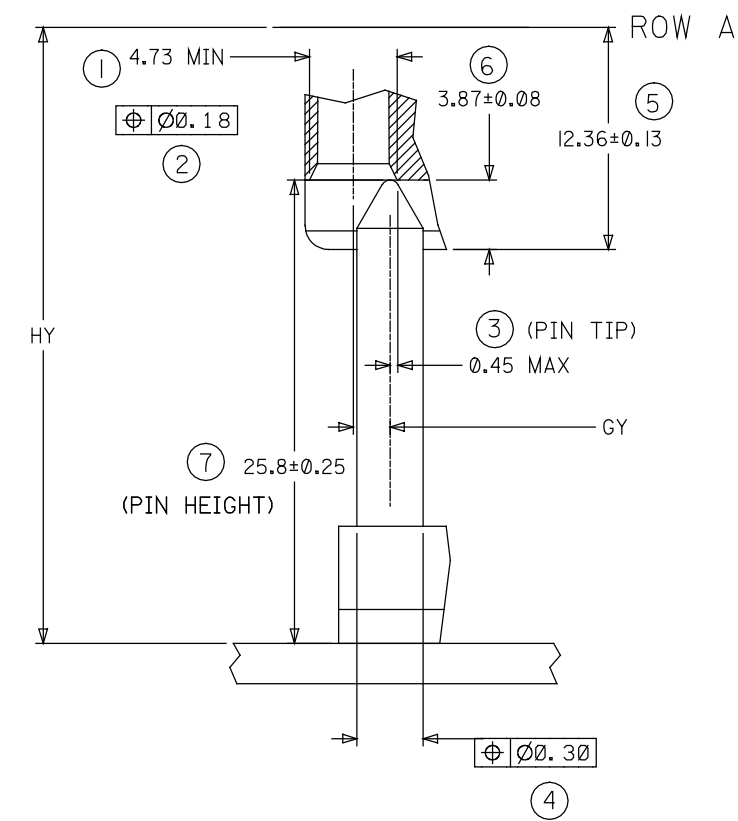

GATHERING:	
2.36	① × 0.5
-0.09	②
-0.45	③
-0.15	④
<hr/>	
GY = 1.67 (WORST CASE)	
ROW A HEIGHT AT GATHERING:	
12.36±0.13	⑤
- 3.87±0.08	⑥
+ 25.8±0.25	⑦
<hr/>	
HY = 34.29±0.46	

VHDM MATING SEQUENCE

6 ROW VHDM

8 ROW VHDM

	ROW A TO BACKPLANE	DISTANCE TO FULL MATE	ROW A TO BACKPLANE	DISTANCE TO FULL MATE
	NOMINAL	NOMINAL	NOMINAL	NOMINAL
GUIDE PIN TIP ENGAGES GROUND MODULE	38.16	23.16	40.01	23.16
GUIDE PIN LEAD-IN FULLY ENGAGED IN GROUND MODULE	34.44	19.44	36.29	19.44
GUIDE PIN TIP ENGAGES GUIDE MODULE	34.31	19.31	36.16	19.31
GUIDE PIN LEAD-IN FULLY ENGAGED IN GUIDE MODULE	30.73	15.73	32.44	15.59
GUIDE PIN ELECTRICALLY CONTACTS GROUND SPRING	30.38	15.38	32.23	15.38
POWER PLASTIC LEAD-IN STARTS	30.00	15.00	31.85	15.00
GUIDE PIN TIP ENGAGES JOINER	28.34	13.34	30.35	13.50
KEYING PIN ENGAGES BUSHING	27.51	12.51	29.36	12.51
SIGNAL WAFER TIP REACHES BP POWER TOP	27.50	12.50	29.35	12.50
POWER PLASTIC FULLY ENGAGED	27.41	12.41	29.26	12.41
DC POWER MODULE REACHES BP HSG TOP	27.16	12.16	29.01	12.16
XL POWER BLADE LEAD-IN START	26.96	11.96	28.81	11.96
L POWER BLADE LEAD-IN START	25.46	10.46	27.31	10.46
SIGNAL WAFER TIP REACHES BP HSG TOP	24.66	9.66	26.51	9.66
GUIDE PIN LEAD-IN FULLY ENGAGED IN JOINER	24.62	9.62	26.63	9.78
XL POWER BLADE MAKES ELECTRICAL CONTACT	24.46	9.46	26.31	9.46
M POWER BLADE LEAD-IN START	23.96	8.96	25.81	8.96
SIGNAL WING ENGAGEMENT STARTS	23.26	8.26	25.11	8.26
L POWER BLADE MAKES ELECTRICAL CONTACT	22.96	7.96	24.81	7.96
S POWER BLADE LEAD-IN START	22.46	7.46	24.31	7.46
SIGNAL WINGS FULLY ENGAGED	21.56	6.56	23.41	6.56
M POWER BLADE MAKES ELECTRICAL CONTACT	21.46	6.46	23.31	6.46
6.25 PIN LEAD-IN START	20.85	5.85	22.70	5.85
SIGNAL WAFER TIP REACHES ADV MATE SHIELD TOP	20.43	5.43	22.28	5.43
SIGNAL WAFER TIP REACHES STD SHIELD TOP	20.25	5.25	22.10	5.25
S POWER BLADE MAKES ELECTRICAL CONTACT	19.96	4.96	21.81	4.96
5.15 PIN LEAD-IN START	19.75	4.75	21.60	4.75
4.75 PIN LEAD-IN START	19.35	4.35	21.20	4.35
4.25 PIN LEAD-IN START	18.85	3.85	20.70	3.85
6.25 PIN MAKES ELECTRICAL CONTACT	18.55	3.55	20.40	3.55
ADV MATE BP SHIELD MAKES ELECTRICAL CONTACT	17.58	2.58	19.43	2.58
ADV MATE BP SHIELD LEAD-IN TO FINGERS START	17.53	2.53	19.38	2.53
5.15 PIN MAKES ELECTRICAL CONTACT	17.45	2.45	19.30	2.45
STD BP SHIELD LEAD-IN TO FINGERS START	17.35	2.35	19.20	2.35
4.75 PIN MAKES ELECTRICAL CONTACT	17.05	2.05	18.90	2.05
STD BP SHIELD MAKES ELECTRICAL CONTACT	16.58	1.58	18.43	1.58
4.25 PIN MAKES ELECTRICAL CONTACT	16.55	1.55	18.40	1.55
SIGNAL WAFER FULLY SEATED	15.00	0.00	16.85	0.00

VHDM SIGNAL PIN WIPE

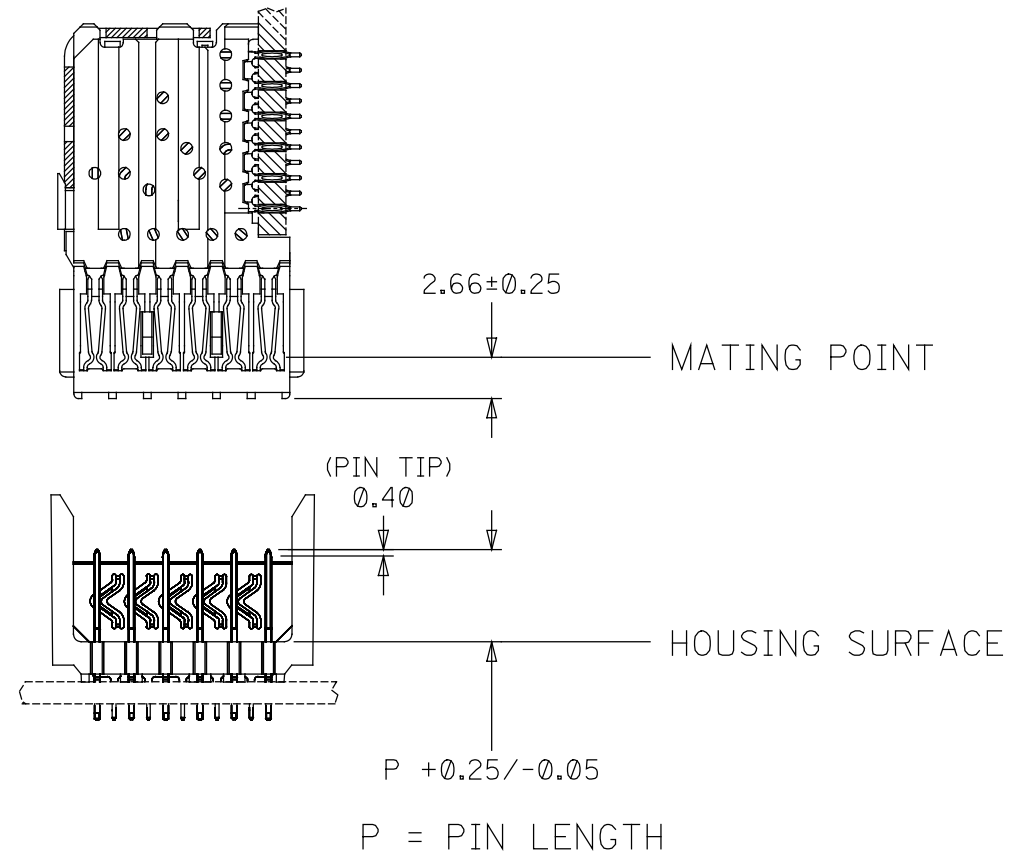

FOR A FULLY SEATED SYSTEM, THE SIGNAL WIPE IS ...

$$\text{WIPE} = P - 2.66 (+0.50 / -0.30)$$

THEREFORE, THE MIN WIPE PER PIN LENGTH IS AS FOLLOWS ...

6.25 PIN	==>	MIN WIPE = 3.29
5.15 PIN	==>	MIN WIPE = 2.19
4.75 PIN	==>	MIN WIPE = 1.79
4.25 PIN	==>	MIN WIPE = 1.29

(NOTE: FOR FULL NORMAL FORCE WIPE, THE PIN TIP (0.40) SHOULD BE SUBTRACTED FROM THE STANDARD WIPE VALUE.)

VHDM CHEVRON WIPE

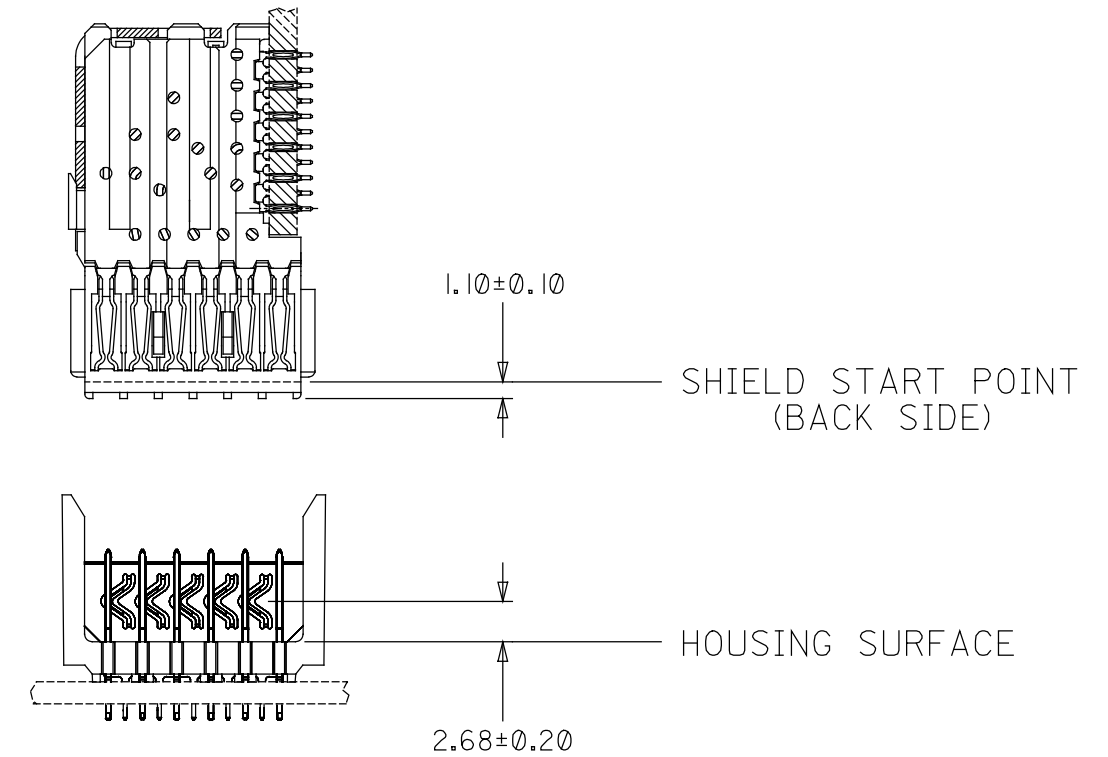

FOR A FULLY SEATED SYSTEM, THE CHEVRON WIPE IS ...

$$\text{WIPE} = 2.68 - 1.10 (\pm 0.30)$$

THEREFORE, THE MIN CHEVRON WIPE IS AS FOLLOWS ...

CHEVRON	==>	MIN WIPE = 1.28
---------	-----	-----------------

VHDM-HSD 5 ROW MATING SEQUENCE**VHDM-HSD 5 ROW**

	ROW A TO BACKPLANE	DISTANCE TO FULL MATE
	<i>NOMINAL</i>	<i>NOMINAL</i>
GUIDE PIN TIP ENGAGES GROUND MODULE	40.16	23.16
GUIDE PIN LEAD-IN FULLY ENGAGED IN GROUND MODULE	36.44	19.44
GUIDE PIN TIP ENGAGES GUIDE MODULE	36.30	19.30
GUIDE PIN LEAD-IN FULLY ENGAGED IN GUIDE MODULE	32.58	15.58
GUIDE PIN ELECTRICALLY CONTACTS GROUND SPRING	32.38	15.38
POWER PLASTIC LEAD-IN STARTS	32.04	15.04
SIGNAL WAFER TIP REACHES BP POWER TOP	29.50	12.50
POWER PLASTIC FULLY ENGAGED	29.44	12.44
DC POWER MODULE REACHES BP HSG TOP	29.16	12.16
GUIDE PIN TIP ENGAGES JOINER	28.76	11.76
L POWER BLADE LEAD-IN START	28.40	11.40
KEYING PIN ENGAGES BUSHING	27.41	10.41
M POWER BLADE LEAD-IN START	26.90	9.90
SIGNAL WAFER TIP REACHES BP HSG TOP	26.66	9.66
L POWER BLADE MAKES ELECTRICAL CONTACT	25.90	8.90
S POWER BLADE LEAD-IN START	25.40	8.40
SIGNAL WING ENGAGEMENT STARTS	25.26	8.26
GUIDE PIN LEAD-IN FULLY ENGAGED IN JOINER	25.04	8.04
M POWER BLADE MAKES ELECTRICAL CONTACT	24.40	7.40
SIGNAL WINGS FULLY ENGAGED	23.56	6.56
S POWER BLADE MAKES ELECTRICAL CONTACT	22.90	5.90
6.25 PIN LEAD-IN START	22.85	5.85
SIGNAL WAFER TIP REACHES ADV MATE SHIELD TOP	22.43	5.43
SIGNAL WAFER TIP REACHES STD SHIELD TOP	22.25	5.25
5.15 PIN LEAD-IN START	21.75	4.75
4.75 PIN LEAD-IN START	21.35	4.35
4.25 PIN LEAD-IN START	20.85	3.85
6.25 PIN MAKES ELECTRICAL CONTACT	20.55	3.55
ADV MATE BP SHIELD MAKES ELECTRICAL CONTACT	19.58	2.58
ADV MATE BP SHIELD LEAD-IN TO FINGERS START	19.53	2.53
5.15 PIN MAKES ELECTRICAL CONTACT	19.45	2.45
STD BP SHIELD LEAD-IN TO FINGERS START	19.35	2.35
4.75 PIN MAKES ELECTRICAL CONTACT	19.05	2.05
STD BP SHIELD MAKES ELECTRICAL CONTACT	18.58	1.58
4.25 PIN MAKES ELECTRICAL CONTACT	18.55	1.55
SIGNAL WAFER FULLY SEATED	17.00	0.00