



## 1 Description

This document concern the main features of PTB801DB valve drivers for ABS board with 2 x L9347 and L9352B devices.

### 1.1 Introduction

The PTB801DB is a complete demonstrator of an ABS and ESC system based on STMicroelectronics devices. The board implements a flexible and open design demonstrating the capability of the STMicroelectronics 16/32 bit microcontrollers and devices for ABS applications. The PTB801DB mounts two L9347 and L9352B devices and accept external signal coming from PTB801 MB.

### 1.2 Main components

- L9347 valve drivers
- L9352B valve drivers
- Connector for valves
- Connector for  $V_{BATT}$  power supply
- Standardized CPU board connector providing access to off board I/O, PWM, SPI and power supply

# Contents

- 1 Description . . . . . 1**
  - 1.1 Introduction . . . . . 1
  - 1.2 Main components . . . . . 1
  
- 2 Evaluation board description . . . . . 5**
  - 2.1 Features . . . . . 5
    - 2.1.1 L9347 quad intelligent power low-side switch . . . . . 5
    - 2.1.2 L9352B quad low-side switch . . . . . 7
  - 2.2 Board connections . . . . . 10
    - 2.2.1 L9347 first valve drivers . . . . . 11
    - 2.2.2 L9347 second valve drivers . . . . . 12
    - 2.2.3 L9352B valve drivers . . . . . 12
    - 2.2.4 Oscillator block . . . . . 13
  
- 3 Before you start . . . . . 15**
  - 3.1 How to exercise diagnostic functionality . . . . . 15
  
- 4 Hardware . . . . . 16**
  - 4.1 Overview . . . . . 16
  
- 5 Revision history . . . . . 17**

## List of tables

Table 1.	Valve connectors J6, J7 and J8 . . . . .	10
Table 2.	Valve connectors J11, J12 and J13 . . . . .	11
Table 3.	Valve connectors J22, J23 and J24 . . . . .	12
Table 4.	Valve connectors J17, J18 and J19 . . . . .	13
Table 5.	Oscillator connectors J20, J21 and J22 . . . . .	14
Table 6.	Document revision history . . . . .	17

# List of figures

Figure 1. L9347 pin connection (top view) . . . . . 5  
Figure 2. L9347 block diagram . . . . . 7  
Figure 3. L9352B pin connection . . . . . 8  
Figure 4. L9352B block diagram . . . . . 9  
Figure 5. 4 valves controlled by first L9347 . . . . . 10  
Figure 6. 4 valves controlled by second L9347 . . . . . 10  
Figure 7. 4 valves controlled by L9352B . . . . . 10  
Figure 8. First L9347 signals monitoring connectors . . . . . 11  
Figure 9. Second L9347 signals monitoring connectors . . . . . 12  
Figure 10. L9352B signals monitoring connectors . . . . . 12  
Figure 11. Oscillator and clock selector . . . . . 13  
Figure 12. Layout of 2 x L9347 and L9352B devices. . . . . 16

## 2 Evaluation board description

The PTB801DB is a valve drivers board for ABS and ESC system based on STMicroelectronics devices. The board implements a flexible and open design demonstrating the capability of the STMicroelectronics for ABS and ESC applications. The PTB801DB mounts two L9347 and L9352B devices, the control coming from PTB801 MB.

The board has opened connectivity to external valves.

### 2.1 Features

General features of this board are:

- Full evaluation and development system based on the system basis chip L9347 and L9352B
- Full system evaluation: integration, basic and safety functionalities

#### 2.1.1 L9347 quad intelligent power low-side switch

The L9347 is an integrated quad low-side power switch to drive inductive loads like valves used in ABS systems. Two of the four channels are current regulators with current range from 250 mA to 2.25 A and an accuracy of 10 %. All channels are protected against fail functions. They are monitored by a status output.

Figure 1. L9347 pin connection (top view)

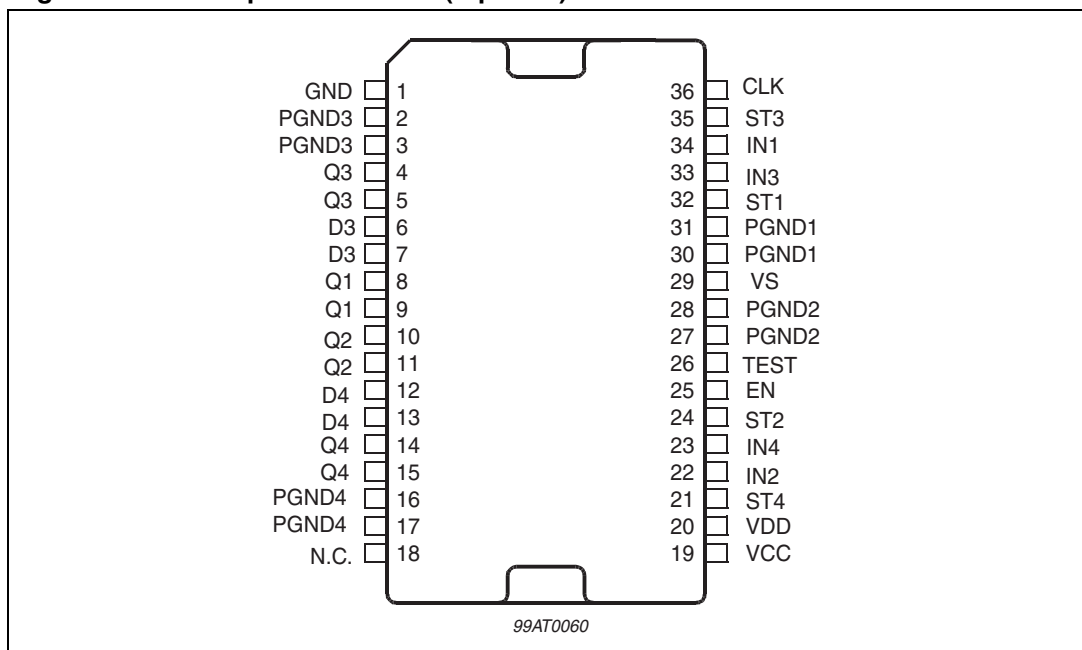

The L9347 is a quad low-side switch with following functions:

- 2 x 5 A designed as conventional switch
- 2 x 2.5 A designed as switched current regulator
- Low ON resistance 2 x 0.2 Ohm, 2 x 0.35 Ohm (typ.)
- PowerSO-36 package with integrated cooling area
- Integrated free wheeling and clamping Z diodes
- Output slope control
- Short circuit protection
- Selective overtemperature shutdown
- Open load detection
- Ground and supply loss detection
- External clock control
- Recirculation control
- Regulator drift detection
- Regulator error control
- Regulator resolution 5 mA
- Status monitoring
- Status push-pull stages
- Electrostatic discharge (ESD) protection

Figure 2. L9347 block diagram

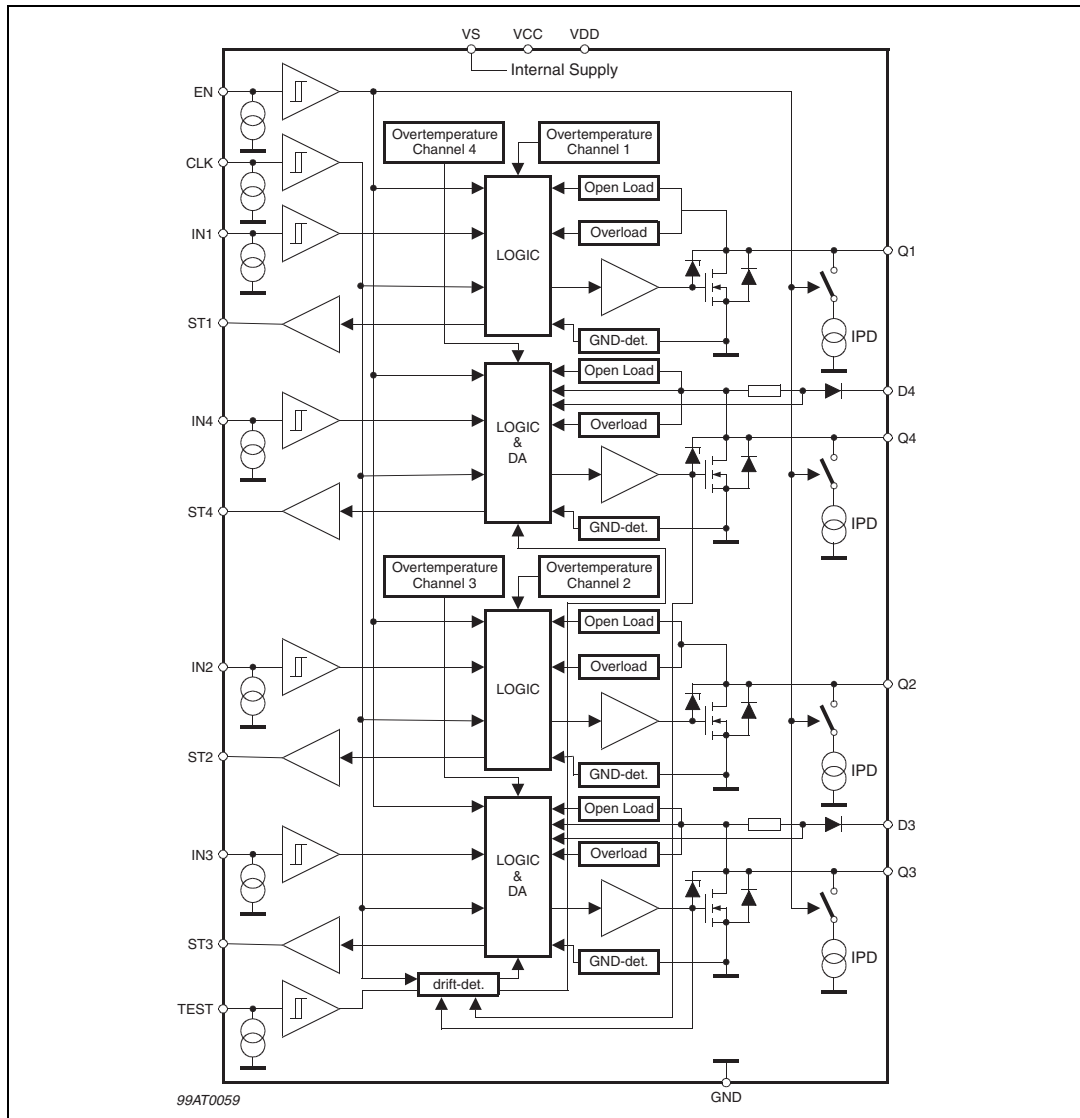

### 2.1.2 L9352B quad low-side switch

The L9352B is an integrated quad low-side power switch to drive inductive loads like valves used in ABS systems. Two of the four channels are current regulators with current range from 0mA to 2.25 A. All channels are protected against fail functions. They are monitored by a status output.

Figure 3. L9352B pin connection

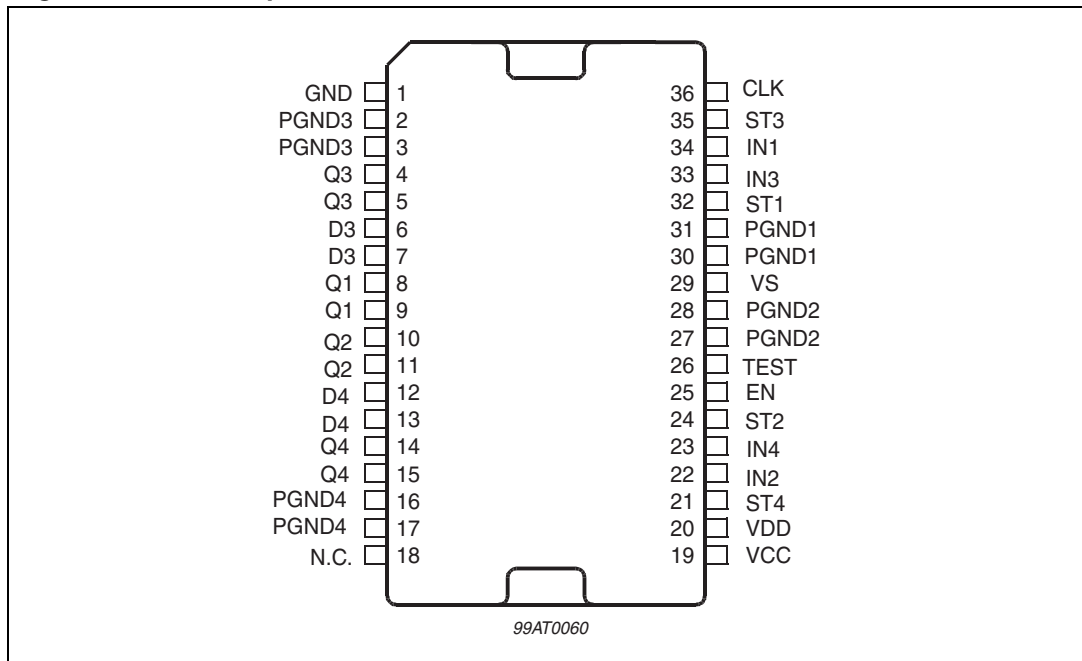

The L9352B is a quad low-side switch with following functions:

- Quad low-side switch
- 2 x 5 A designed as conventional switch
- 2 x 2.5 A designed as switched current-regulator
- Low ON-resistance 4 x 0.2 Ohm (typ.)
- PowerSO-36 package with integrated cooling area
- Integrated free-wheeling and clamping Z-diodes
- Output slope control
- Short circuit protection
- Selective overtemperature shutdown
- Open load detection
- Ground and supply loss detection
- External clock control
- Recirculation control
- Regulator drift detection
- Regulator error control
- Regulator resolution 5 mA
- Status monitoring
- Status push-pull stages
- Electrostatic discharge (ESD) protection



Figure 4. L9352B block diagram

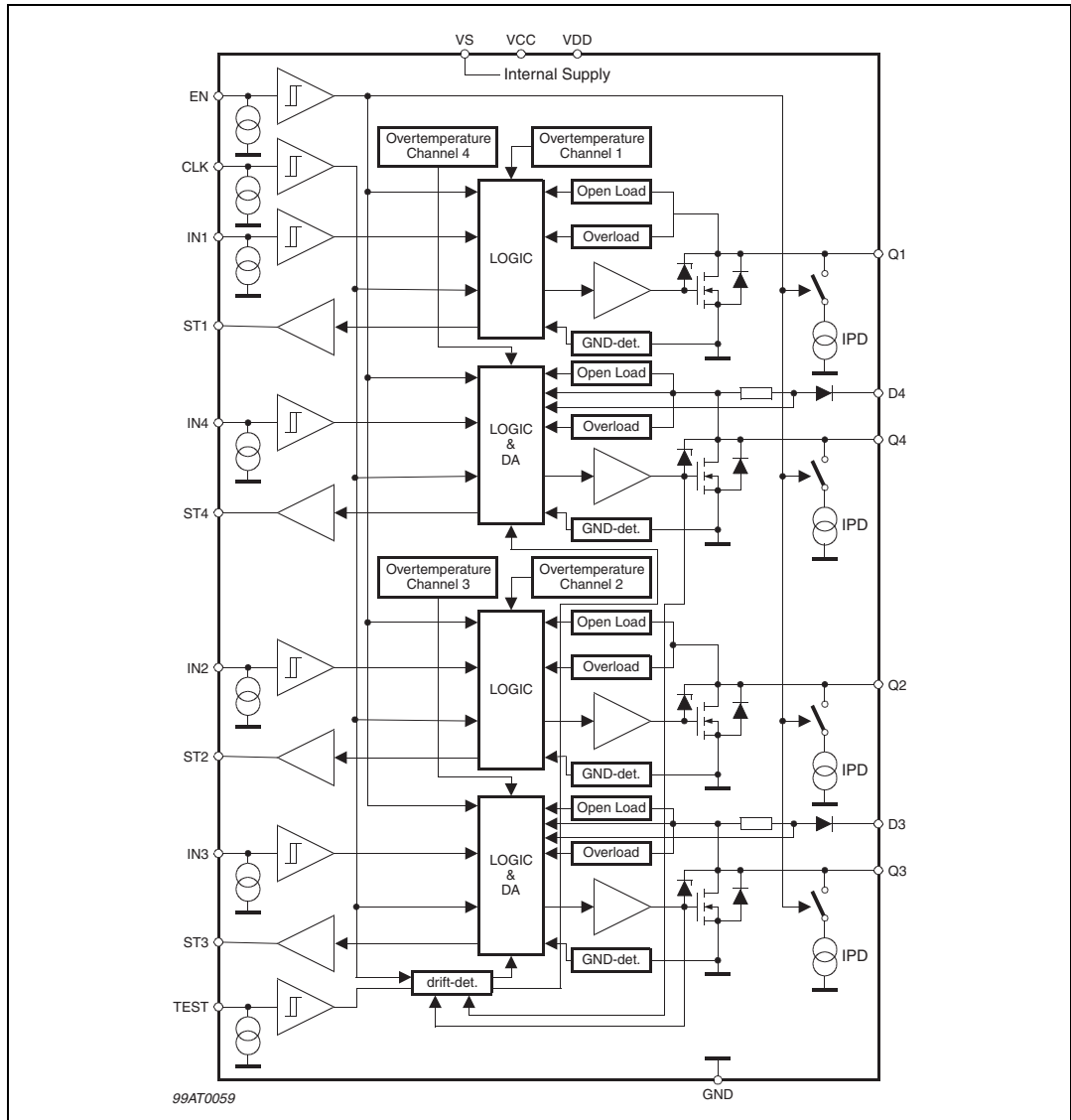

## 2.2 Board connections

PTB801DB has many connector to communicate with:

- PTB801 mother board;
- External valves;
- I/O signals to control valve drivers.

**Figure 5. 4 valves controlled by first L9347**

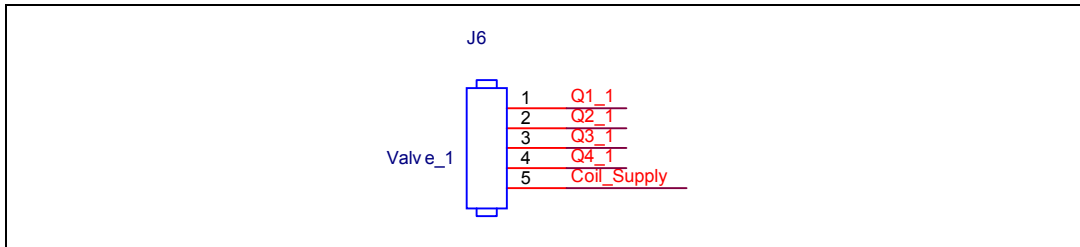

**Figure 6. 4 valves controlled by second L9347**

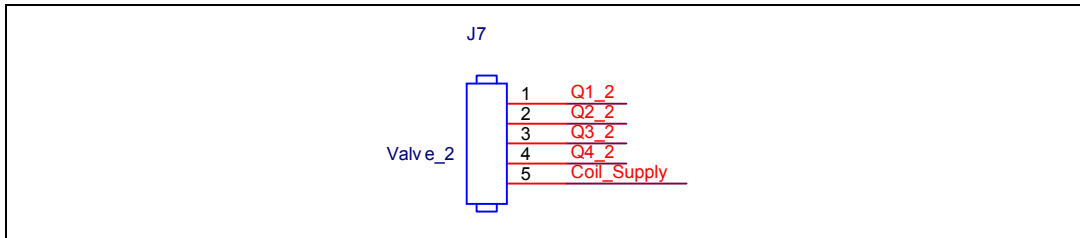

**Figure 7. 4 valves controlled by L9352B**

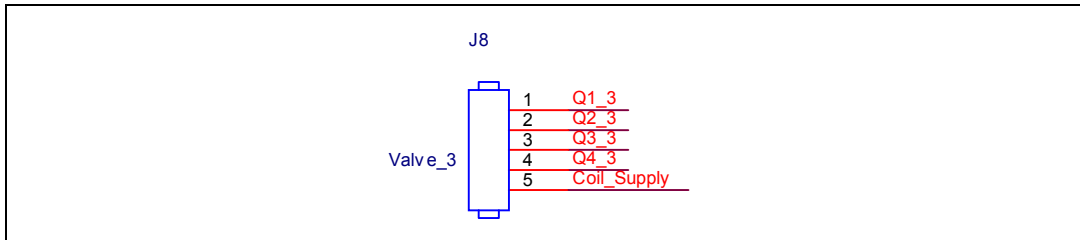

The [Table 1](#) describes the pin out of the valve connectors J5 and J6:

**Table 1. Valve connectors J6, J7 and J8**

Name	Figure	Description
J6Pin 1	<i>Figure 5</i>	Output Q1 of first L9347
J6 Pin 2		Output Q2 of first L9347
J6 Pin 3		Output Q3 of first L9347
J6 Pin 4		Output Q4 of first L9347
J6 Pin 5		Coil Supply

**Table 1. Valve connectors J6, J7 and J8 (continued)**

Name	Figure	Description
J7 Pin 1	<i>Figure 6</i>	Output Q1 of second L9347
J7 Pin 2		Output Q2 of second L9347
J7 Pin 3		Output Q3 of second L9347
J7 Pin 4		Output Q4 of second L9347
J7 Pin 5		Coil Supply
J8 Pin 1	<i>Figure 7</i>	Output Q1 of L9352B
J8 Pin 2		Output Q2 of L9352B
J8 Pin 3		Output Q3 of L9352B
J8 Pin 4		Output Q4 of L9352B
J8 Pin 5		Coil Supply

### 2.2.1 L9347 first valve drivers

On the board, there are three connectors to monitoring the input (INx\_1), output (Qx\_1), and status (STx\_1) of the first L9347 drivers.

**Figure 8. First L9347 signals monitoring connectors**

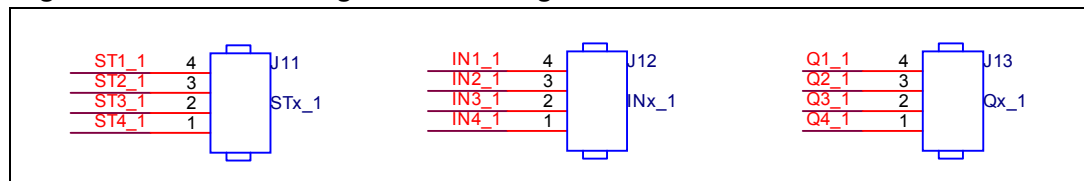

The [Table 2](#) describes the pin out of the first signals monitoring connectors J11, J12 and J13:

**Table 2. Valve connectors J11, J12 and J13**

Name	Figure	Description
J11 Pin 1	<i>Figure 8.</i>	Status Q1 of first L9347 driver
J11 Pin 2		Status Q2 of first L9347 driver
J11 Pin 3		Status Q3 of first L9347 driver
J11 Pin 4		Status Q4 of first L9347 driver
J12 Pin 1		Input Q1 of first L9347 driver
J12 Pin 2		Input Q2 of first L9347 driver
J12 Pin 3		Input Q3 of first L9347 driver
J12 Pin 4		Input Q4 of first L9347 driver
J13 Pin 1		Output Q1 of first L9347 driver
J13 Pin 2		Output Q2 of first L9347 driver
J13 Pin 3		Output Q3 of first L9347 driver
J13 Pin 4		Output Q4 of first L9347 driver

### 2.2.2 L9347 second valve drivers

On the board, there are three connectors to monitoring the input (INx\_2), output (Qx\_2), and status (STx\_2) of the second L9347 drivers.

**Figure 9. Second L9347 signals monitoring connectors**

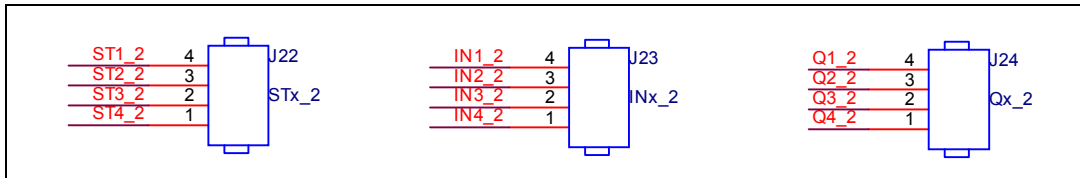

The [Table 3](#) describes the pin out of the second L9347 signals monitoring connectors J22, J23 and J24:

**Table 3. Valve connectors J22, J23 and J24**

Name	Figure	Description
J22 Pin 1	<i>Figure 9.</i>	Status Q1 of second L9347 driver
J22 Pin 2		Status Q2 of second L9347 driver
J22 Pin 3		Status Q3 of second L9347 driver
J22 Pin 4		Status Q4 of second L9347 driver
J23 Pin 1		Input Q1 of second L9347 driver
J23 Pin 2		Input Q2 of second L9347 driver
J23 Pin 3		Input Q3 of second L9347 driver
J23 Pin 4		Input Q4 of second L9347 driver
J24 Pin 1		Output Q1 of second L9347 driver
J24 Pin 2		Output Q2 of second L9347 driver
J24 Pin 3		Output Q3 of second L9347 driver
J24 Pin 4		Output Q4 of second L9347 driver

### 2.2.3 L9352B valve drivers

On the board, there are three connectors to monitoring the input (INx\_2), output (Qx\_2), and status (STx\_2) of the L9352B drivers.

**Figure 10. L9352B signals monitoring connectors**

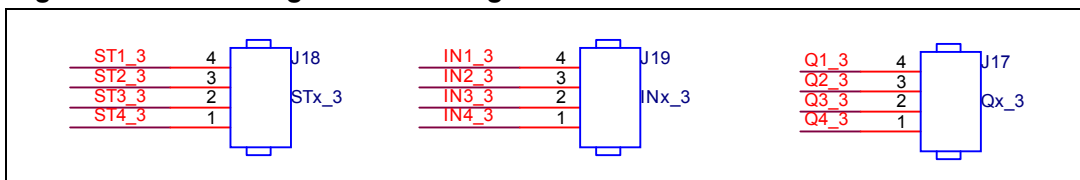

The [Table 4](#) describes the pin out of the L9352B signals monitoring connectors J18, J19 and J17:

**Table 4. Valve connectors J17, J18 and J19**

Name	Figure	Description
J18 Pin 1	<i>Figure 10.</i>	Status Q1 of L9352B driver
J18 Pin 2		Status Q2 of L9352B driver
J18 Pin 3		Status Q3 of L9352B driver
J18 Pin 4		Status Q4 of L9352B driver
J19 Pin 1		Input Q1 of L9352B driver
J19 Pin 2		Input Q2 of L9352B driver
J19 Pin 3		Input Q3 of L9352B driver
J19 Pin 4		Input Q4 of L9352B driver
J17 Pin 1		Output Q1 of L9352B driver
J17 Pin 2		Output Q2 of L9352B driver
J17 Pin 3		Output Q3 of L9352B driver
J17 Pin 4		Output Q4 of L9352B driver

### 2.2.4 Oscillator block

To obtain clock at 250 kHz frequency, has been used an oscillator to 1 MHz and a counter (for frequency division). In this way is possible obtain the 250 kHz needed for L9352B, from different oscillator. Otherwise, is possible connect the CLK line with line coming from μC.

**Figure 11. Oscillator and clock selector**

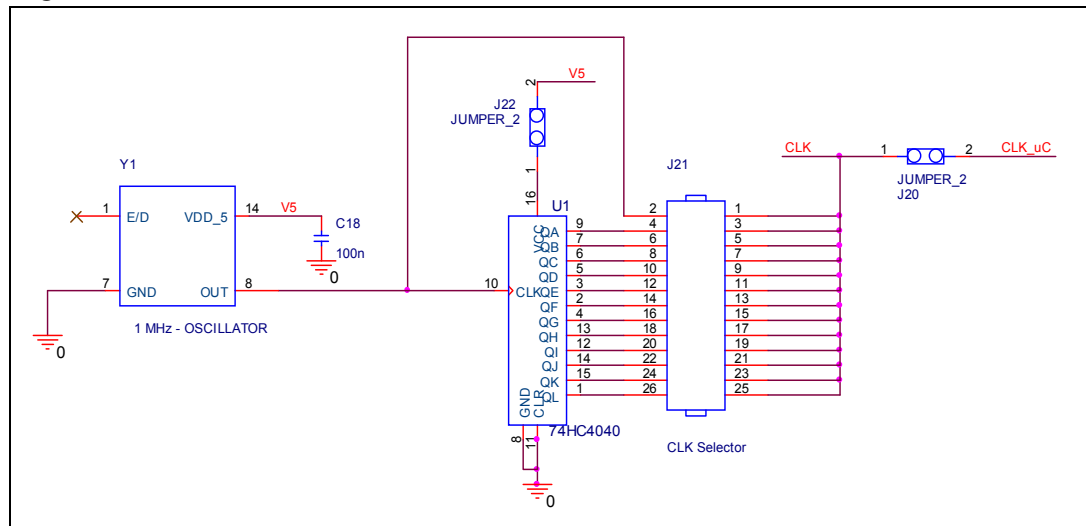

The following table describes the pin out of connectors J20, J21 and J22:

**Table 5. Oscillator connectors J20, J21 and J22**

Name	Figure	Description
J20 Pin 1	<i>Figure 11.</i>	CLK og L9352B driver
J20 Pin 2		CLK_uC coming from uC
J21 Pin 1 and 2		Oscillator CLK/1
J21 Pin 3 and 4		Oscillator CLK/2
J21 Pin 5 and 6		Oscillator CLK/4
J21 Pin 7 and 8		Oscillator CLK/8
J21 Pin 9 and 10		Oscillator CLK/16
J21 Pin 11 and 12		Oscillator CLK/32
J21 Pin 13 and 14		Oscillator CLK/64
J21 Pin 15 and 16		Oscillator CLK/128
J21 Pin 17 and 18		Oscillator CLK/256
J21 Pin 19 and 20		Oscillator CLK/512
J21 Pin 21 and 22		Oscillator CLK/1024
J21 Pin 23 and 24		Oscillator CLK/2048
J21 Pin 25 and 26		Oscillator CLK/4096
J22 Pin 1		74HC4040 Vcc
J22 Pin 2		Vcc 5V

## 3 Before you start

This section describes operations needed before powering up the board.

Before powering up the mother board, could connect:

- Daughter board PTB801DB
- Wheel speed sensor board
- $\mu$ C mini module (ST10/JPC family)

### 3.1 How to exercise diagnostic functionality

The PTB801DB has many diagnostic features. Please see the L9347 and L9352B datasheet for detail.

# 4 Hardware

This chapter describes all the hardware modules of the board.

## 4.1 Overview

The PTB801DB is a specific platform for ABS and ESC valve drivers system with parallel interface.

Figure 12. Layout of 2 x L9347 and L9352B devices

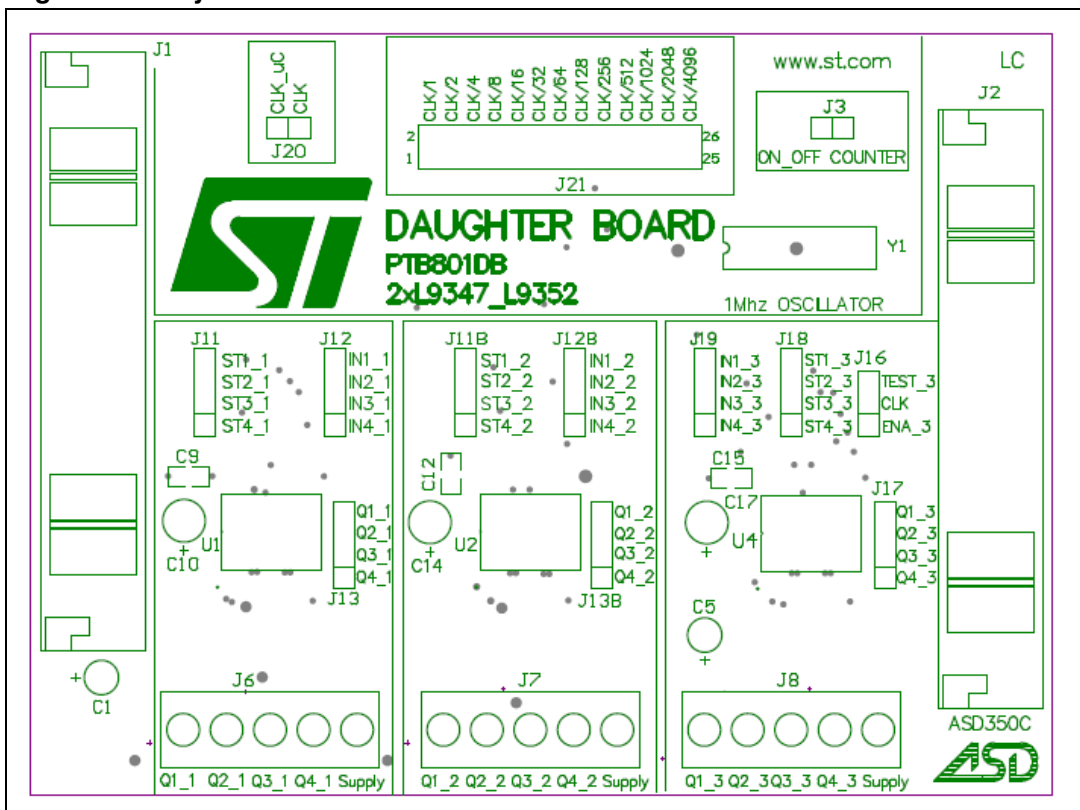



## 5 Revision history

**Table 6. Document revision history**

Date	Revision	Changes
28-May-2009	1	Initial release.
17-Sep-2013	2	Updated Disclaimer.

**Please Read Carefully:**

Information in this document is provided solely in connection with ST products. STMicroelectronics NV and its subsidiaries ("ST") reserve the right to make changes, corrections, modifications or improvements, to this document, and the products and services described herein at any time, without notice.

All ST products are sold pursuant to ST's terms and conditions of sale.

Purchasers are solely responsible for the choice, selection and use of the ST products and services described herein, and ST assumes no liability whatsoever relating to the choice, selection or use of the ST products and services described herein.

No license, express or implied, by estoppel or otherwise, to any intellectual property rights is granted under this document. If any part of this document refers to any third party products or services it shall not be deemed a license grant by ST for the use of such third party products or services, or any intellectual property contained therein or considered as a warranty covering the use in any manner whatsoever of such third party products or services or any intellectual property contained therein.

**UNLESS OTHERWISE SET FORTH IN ST'S TERMS AND CONDITIONS OF SALE ST DISCLAIMS ANY EXPRESS OR IMPLIED WARRANTY WITH RESPECT TO THE USE AND/OR SALE OF ST PRODUCTS INCLUDING WITHOUT LIMITATION IMPLIED WARRANTIES OF MERCHANTABILITY, FITNESS FOR A PARTICULAR PURPOSE (AND THEIR EQUIVALENTS UNDER THE LAWS OF ANY JURISDICTION), OR INFRINGEMENT OF ANY PATENT, COPYRIGHT OR OTHER INTELLECTUAL PROPERTY RIGHT.**

**ST PRODUCTS ARE NOT DESIGNED OR AUTHORIZED FOR USE IN: (A) SAFETY CRITICAL APPLICATIONS SUCH AS LIFE SUPPORTING, ACTIVE IMPLANTED DEVICES OR SYSTEMS WITH PRODUCT FUNCTIONAL SAFETY REQUIREMENTS; (B) AERONAUTIC APPLICATIONS; (C) AUTOMOTIVE APPLICATIONS OR ENVIRONMENTS, AND/OR (D) AEROSPACE APPLICATIONS OR ENVIRONMENTS. WHERE ST PRODUCTS ARE NOT DESIGNED FOR SUCH USE, THE PURCHASER SHALL USE PRODUCTS AT PURCHASER'S SOLE RISK, EVEN IF ST HAS BEEN INFORMED IN WRITING OF SUCH USAGE, UNLESS A PRODUCT IS EXPRESSLY DESIGNATED BY ST AS BEING INTENDED FOR "AUTOMOTIVE, AUTOMOTIVE SAFETY OR MEDICAL" INDUSTRY DOMAINS ACCORDING TO ST PRODUCT DESIGN SPECIFICATIONS. PRODUCTS FORMALLY ESCC, QML OR JAN QUALIFIED ARE DEEMED SUITABLE FOR USE IN AEROSPACE BY THE CORRESPONDING GOVERNMENTAL AGENCY.**

Resale of ST products with provisions different from the statements and/or technical features set forth in this document shall immediately void any warranty granted by ST for the ST product or service described herein and shall not create or extend in any manner whatsoever, any liability of ST.

ST and the ST logo are trademarks or registered trademarks of ST in various countries.

Information in this document supersedes and replaces all information previously supplied.

The ST logo is a registered trademark of STMicroelectronics. All other names are the property of their respective owners.

© 2013 STMicroelectronics - All rights reserved

STMicroelectronics group of companies

Australia - Belgium - Brazil - Canada - China - Czech Republic - Finland - France - Germany - Hong Kong - India - Israel - Italy - Japan - Malaysia - Malta - Morocco - Philippines - Singapore - Spain - Sweden - Switzerland - United Kingdom - United States of America

[www.st.com](http://www.st.com)