



**Fiery Network Controller
for DocuColor 3535**

PRINTING GUIDE



About the Documentation

This manual is part of a set of Fiery Network Controller for DocuColor 3535™ documentation that includes the following manuals for users and system administrators:

- The *Quick Start Guide* summarizes the steps for configuring the Fiery Network Controller for DocuColor 3535 and printing. It also describes how to access the online documentation.
- The *User Software Installation Guide* describes how to install software from the User Software CD to enable users to print to the Fiery Network Controller for DocuColor 3535, and also describes setting up printing connections to the Fiery Network Controller for DocuColor 3535.
- The *Configuration Guide* explains basic configuration and administration of the Fiery Network Controller for DocuColor 3535 for the supported platforms and network environments. It also includes guidelines for setting up UNIX, Windows NT 4.0/2000, and Novell NetWare servers to provide printing services to users.
- The *Printing Guide* describes the printing features of the Fiery Network Controller for DocuColor 3535 for users who send jobs from their computers.
- The *Color Guide* provides information on managing the color output of the Fiery Network Controller for DocuColor 3535. It explains how to calibrate your copier and take advantage of the ColorWise® color management system, as well as features in ColorWise Pro Tools™.
- The *Fiery Color Reference* addresses concepts and issues associated with managing color output of the Fiery Network Controller for DocuColor 3535 and outlines key workflow scenarios. In addition, it offers information on printing color documents from popular Microsoft Windows and Apple Mac OS applications.
- The *Job Management Guide* explains the functions of job management utilities, including Command WorkStation™ and DocBuilder Pro™, and how you can use them to monitor and manage jobs on the Fiery Network Controller for DocuColor 3535. This manual is intended for an operator, administrator, or a user with the necessary access privileges, who monitors and manages job flow, and troubleshoots problems that may arise.
- *Customer Release Notes* provide last-minute product information and workarounds for some of the problems you may encounter.

Copyright © 2003 Electronics For Imaging, Inc. All rights reserved.

This publication is protected by copyright, and all rights are reserved. No part of it may be reproduced or transmitted in any form or by any means for any purpose without express prior written consent from Electronics For Imaging, Inc., except as expressly permitted herein. Information in this document is subject to change without notice and does not represent a commitment on the part of Electronics For Imaging, Inc.

The software described in this publication is furnished under license and may only be used or copied in accordance with the terms of such license.

This product may be covered by one or more of the following U.S. Patents: 4,500,919, 4,837,722, 5,212,546, 5,343,311, 5,424,754, 5,467,446, 5,506,946, 5,517,334, 5,537,516, 5,543,940, 5,553,200, 5,615,314, 5,619,624, 5,625,712, 5,666,436, 5,760,913, 5,818,645, 5,835,788, 5,867,179, 5,959,867, 5,970,174, 5,982,937, 5,995,724, 6,002,795, 6,025,922, 6,041,200, 6,065,041, 6,112,665, 6,122,407, 6,134,018, 6,141,120, 6,166,821, 6,185,335, 6,201,614, 6,215,562, 6,219,659, 6,222,641, 6,224,048, 6,225,974, 6,226,419, 6,238,105, 6,239,895, 6,256,108, 6,269,190, 6,289,122, 6,292,270, 6,310,697, 6,327,047, 6,327,050, 6,327,052, RE36,947, D406,117, D416,550, D417,864, D419,185, D426,206, D439,851, D444,793

Trademarks

ColorWise, EDOX, EFI, Fiery, the Fiery logo, Fiery Driven and RIP-While-Print are registered trademarks of Electronics For Imaging, Inc. in the U.S. Patent and Trademark Office and/or certain other foreign jurisdictions.

The eBeam logo, the Electronics For Imaging logo, the Fiery Driven logo, the PrintMe logo, the Splash logo, AutoCal, ColorCal, Command WorkStation, DocBuilder, DocBuilder Pro, DocStream, eBeam, EFI Color Profiler, EFI Production System, EFI ScanBuilder, Fiery X2, Fiery X2e, Fiery X2-W, Fiery X3e, Fiery X4, Fiery ZX, Fiery Z4, Fiery Z5, Fiery Z9, Fiery Z16, Fiery Z18, Fiery Document WorkStation, Fiery Downloader, Fiery Driver, Fiery FreeForm, Fiery Link, Fiery Prints, Fiery Print Calibrator, Fiery Production System, Fiery Scan, Fiery ScanBuilder, Fiery Spark, Fiery Spooler, Fiery WebInstaller, Fiery WebScan, Fiery WebSpooler, Fiery WebStatus, Fiery WebTools, NetWise, PrintMe, PrintMe Networks, Print Me. Everywhere You Go, RIPChips, Splash, Velocity, Velocity Balance, Velocity Build, Velocity Design, Velocity Estimate, Velocity Scan, and VisualCal are trademarks of Electronics For Imaging, Inc.

All other terms and product names may be trademarks or registered trademarks of their respective owners, and are hereby acknowledged.

Legal Notices

APPLE COMPUTER, INC. ("APPLE") MAKES NO WARRANTIES, EXPRESS OR IMPLIED, INCLUDING WITHOUT LIMITATION THE IMPLIED WARRANTIES OF MERCHANTABILITY AND FITNESS FOR A PARTICULAR PURPOSE, REGARDING THE APPLE SOFTWARE. APPLE DOES NOT WARRANT, GUARANTEE, OR MAKE ANY REPRESENTATIONS REGARDING THE USE OR THE RESULTS OF THE USE OF THE APPLE SOFTWARE IN TERMS OF ITS CORRECTNESS, ACCURACY, RELIABILITY, CURRENTNESS, OR OTHERWISE. THE ENTIRE RISK AS TO THE RESULTS AND PERFORMANCE OF THE APPLE SOFTWARE IS ASSUMED BY YOU. THE EXCLUSION OF IMPLIED WARRANTIES IS NOT PERMITTED BY SOME STATES. THE ABOVE EXCLUSION MAY NOT APPLY TO YOU.

IN NO EVENT WILL APPLE, ITS DIRECTORS, OFFICERS, EMPLOYEES OR AGENTS BE LIABLE TO YOU FOR ANY CONSEQUENTIAL, INCIDENTAL OR INDIRECT DAMAGES (INCLUDING DAMAGES FOR LOSS OF BUSINESS PROFITS, BUSINESS INTERRUPTION, LOSS OF BUSINESS INFORMATION, AND THE LIKE) ARISING OUT OF THE USE OR INABILITY TO USE THE APPLE SOFTWARE EVEN IF APPLE HAS BEEN ADVISED OF THE POSSIBILITY OF SUCH DAMAGES. BECAUSE SOME STATES DO NOT ALLOW THE EXCLUSION OR LIMITATION OF LIABILITY FOR CONSEQUENTIAL OR INCIDENTAL DAMAGES, THE ABOVE LIMITATIONS MAY NOT APPLY TO YOU. Apple's liability to you for actual damages from any cause whatsoever, and regardless of the form of the action (whether in contract, tort [including negligence], product liability or otherwise), will be limited to \$50.

Restricted Rights Legends

For defense agencies: Restricted Rights Legend. Use, reproduction, or disclosure is subject to restrictions set forth in subparagraph (c)(1)(ii) of the Rights in Technical Data and Computer Software clause at 252.227.7013.

For civilian agencies: Restricted Rights Legend. Use, reproduction, or disclosure is subject to restrictions set forth in subparagraph (a) through (d) of the commercial Computer Software Restricted Rights clause at 52.227-19 and the limitations set forth in Electronics For Imaging's standard commercial agreement for this software. Unpublished rights reserved under the copyright laws of the United States.

Part Number: 45023151

FCC Information

WARNING: FCC Regulations state that any unauthorized changes or modifications to this equipment not expressly approved by the manufacturer could void the user's authority to operate this equipment.

Class A Compliance

This equipment has been tested and found to comply with the limits for a Class A digital device, pursuant to Part 15 of the FCC Rules. These limits are designed to provide reasonable protection against harmful interference when the equipment is operated in a commercial environment. This equipment generates, and uses, and can radiate radio frequency energy and, if not installed and used in accordance with the instruction manual, may cause harmful interference to radio communications. Operation of this equipment in a residential area is likely to cause interference in which case the user will be required to correct the interference at his own expense.

Industry Canada Class A Notice

This Class A digital apparatus complies with Canadian ICES-003.

Avis de Conformation Classe A de l'Industrie Canada

Cet appareil numérique de la Classe A est conforme à la norme NMB-003 du Canada.

RFI Compliance Notice

This equipment has been tested concerning compliance with the relevant RFI protection requirements both individually and on system level (to simulate normal operation conditions). However, it is possible that these RFI Requirements are not met under certain unfavorable conditions in other installations. It is the user who is responsible for compliance of his particular installation.

Dieses Gerät wurde sowohl einzeln als auch in einer Anlage, die einen normalen Anwendungsfall nachbildet, auf die Einhaltung der Funkstörbestimmungen geprüft. Es ist jedoch möglich, dass die Funkstörbestimmungen unter ungünstigen Umständen bei anderen Gerätekombinationen nicht eingehalten werden. Für die Einhaltung der Funkstörbestimmungen einer gesamten Anlage, in der dieses Gerät betrieben wird, ist der Betreiber verantwortlich.

Compliance with applicable regulations depends on the use of shielded cables. It is the user who is responsible for procuring the appropriate cables.

Die Einhaltung zutreffender Bestimmungen hängt davon ab, dass geschirmte Ausführungen benützt werden. Für die Beschaffung richtiger Ausführungen ist der Betreiber verantwortlich.

Software License Agreement

YOU SHOULD CAREFULLY READ THE FOLLOWING TERMS AND CONDITIONS BEFORE USING THIS SOFTWARE. IF YOU DO NOT AGREE TO THE TERMS AND CONDITIONS OF THIS AGREEMENT, DO NOT USE THE SOFTWARE. INSTALLING OR USING THE SOFTWARE INDICATES THAT YOU AGREE TO AND ACCEPT THE TERMS OF THIS AGREEMENT. IF YOU DO NOT AGREE TO ACCEPT THE TERMS OF THIS AGREEMENT YOU MAY RETURN THE UNUSED SOFTWARE FOR A FULL REFUND TO THE PLACE OF PURCHASE.

License

EFI grants you a non-exclusive license to use the software ("Software") and accompanying documentation ("Documentation") included with the Product. The Software is licensed, not sold. You may use the Software solely for your own customary business or personal purposes. You may not rent, lease, sublicense or lend the Software. You may, however, permanently transfer all of your rights under this Agreement to another person or legal entity provided that: (1) you transfer to the person or entity all of the Software and Documentation (including all copies, updates, upgrades, prior versions, component parts, the media and printed materials, and this Agreement); (2) you retain no copies of the Software and Documentation, including copies stored on a computer; and (3) the recipient agrees to the terms and conditions of this Agreement.

You may not make or have made, or permit to be made, any copies of the Software or portions thereof, except as necessary for backup or archive purposes in support of your use of the Software as permitted hereunder. You may not copy the Documentation. You may not attempt to alter, disassemble, decompile, decrypt or reverse engineer the Software.

Proprietary Rights

You acknowledge that the Software is proprietary to EFI and its suppliers and that title and other intellectual property rights therein remain with EFI and its suppliers. Except as stated above, this Agreement does not grant you any right to patents, copyrights, trade secrets, trademarks (whether registered or unregistered), or any other rights, franchises or licenses in respect of the Software. You may not adopt or use any trademark or trade name which is likely to be similar to or confusing with that of EFI or any of its suppliers or take any other action which impairs or reduces the trademark rights of EFI or its suppliers.

Confidentiality

You agree to hold the Software in confidence, disclosing the Software only to authorized users having a need to use the Software as permitted by this Agreement and to take all reasonable precautions to prevent disclosure to other parties.

Remedies and Termination

Unauthorized use, copying or disclosure of the Software, or any breach of this Agreement will result in automatic termination of this license and will make available to EFI other legal remedies. In the event of termination, you must destroy all copies of the Software and all of its component parts. All provisions of this Agreement relating to disclaimers of warranties, limitation of liability, remedies, damages, and EFI's proprietary rights shall survive termination.

Limited Warranty and Disclaimer

EFI warrants to the original purchaser ("Customer") for thirty (30) days from the date of original purchase from EFI or its authorized retailer that the Software will perform in substantial conformance to the Documentation when the Product is used as authorized by EFI's specifications. EFI warrants the media containing the Software against failure during the above warranty period. EFI makes no warranty or representation that the Software will meet your specific requirements, that the operation of the Software will be uninterrupted or error free, or that all defects in the Software will be corrected. EFI makes no warranty, implied or otherwise, regarding the performance or reliability of any third party products (software or hardware) not provided by EFI. THE INSTALLATION OF ANY THIRD PARTY PRODUCTS OTHER THAN AS AUTHORIZED BY EFI WILL VOID THIS WARRANTY. IN ADDITION, USE, MODIFICATION, AND/OR REPAIR OF THE PRODUCT OTHER THAN AS AUTHORIZED BY EFI WILL VOID THIS WARRANTY.

EXCEPT FOR THE ABOVE EXPRESS LIMITED WARRANTY, EFI MAKES AND YOU RECEIVE NO WARRANTIES OR CONDITIONS ON THE SOFTWARE, EXPRESS, IMPLIED, STATUTORY, OR IN ANY OTHER PROVISION OF THIS AGREEMENT OR COMMUNICATION WITH YOU, AND EFI SPECIFICALLY DISCLAIMS ANY IMPLIED WARRANTY OR CONDITION OF MERCHANTABILITY OR FITNESS FOR A PARTICULAR PURPOSE OR NONINFRINGEMENT OF THIRD PARTY RIGHTS.

Limitation of Liability

TO THE MAXIMUM EXTENT PERMITTED BY LAW, EFI AND ITS SUPPLIERS SHALL NOT BE LIABLE FOR ANY DAMAGES, INCLUDING LOSS OF DATA, LOST PROFITS, COST OF COVER OR OTHER SPECIAL, INCIDENTAL, CONSEQUENTIAL OR INDIRECT DAMAGES ARISING FROM THE SALE, INSTALLATION, MAINTENANCE, USE, PERFORMANCE OR FAILURE OF THE SOFTWARE, HOWEVER CAUSED AND ON ANY THEORY OF LIABILITY. THIS LIMITATION WILL APPLY EVEN IF EFI HAS BEEN ADVISED OF THE POSSIBILITY OF SUCH DAMAGE. YOU ACKNOWLEDGE THAT THE PRICE OF THE PRODUCT REFLECTS THIS ALLOCATION OF RISK. BECAUSE SOME JURISDICTIONS DO NOT ALLOW THE EXCLUSION OR LIMITATION OF LIABILITY FOR CONSEQUENTIAL OR INCIDENTAL DAMAGES, THE ABOVE LIMITATION MAY NOT APPLY TO YOU.

Export Controls

You agree that you will not export or re-export the Software in any form in violation of any applicable laws or regulations of the United States or the country in which you obtained them.

U.S. Government Restricted Rights:

The Software and Documentation are provided with RESTRICTED RIGHTS. Use, duplication, or disclosure by the United States Government is subject to restrictions as set forth in subparagraph (c)(1)(ii) of the Rights in Technical Data and Computer Software clause at DFARS 252.227-7013 or subparagraphs (c)(1) and (2) of the Commercial Computer Software Restricted Rights at 48 CFR 52.227-19, as applicable.

General

The laws of the State of California govern this Agreement. You agree that this Agreement shall not be subject to the United Nations Convention on Contracts for the International Sale of Goods (1980). This Agreement is the entire agreement held between us and supersedes any other communications or advertising with respect to the Software. If any provision of this Agreement is held invalid, the remainder of this Agreement shall continue in full force and effect.

If you have any questions, please see EFI's web site at www.efi.com.

Electronics For Imaging
303 Velocity Way
Foster City, CA 94404

Contents

About the Documentation

Introduction

About this manual	xi
-------------------	----

Chapter 1: Printing from Windows Computers

Printing from applications	1-1
Setting options and printing from Windows computers	1-2
Using job templates	1-7
Using Shortcuts	1-12
<hr/>	
Defining and printing custom page sizes	1-13
Working with custom page sizes in the Windows 9x/Me PostScript printer driver	1-14
Working with custom page sizes in the Windows NT PostScript printer driver	1-17
Working with custom page sizes in the Windows 2000/XP PostScript printer driver	1-20
Saving files to print at a remote location	1-22

Chapter 2: Printing from Mac OS Computers

Printing from applications with Mac OS 9 and earlier or Mac OS X (Classic mode)	2-1
Selecting the Fiery in the Chooser	2-1
Setting options and printing from Mac OS 9 and earlier or Mac OS X (Classic mode) computers	2-3
Defining custom page sizes	2-7
<hr/>	
Printing from applications with Mac OS X (Native mode)	2-9
Setting options and printing from Mac OS X (Native mode)	2-9
Defining custom page sizes	2-11

Chapter 3: Printing from UNIX Workstations

Printing to the Fiery	3-1
------------------------------	-----

Chapter 4: Downloading Files and Fonts

Using Fiery Downloader or WebDownloader	4-1
Downloading printer fonts	4-4
Managing printer fonts	4-9

Chapter 5: Printing Variable Data Documents

About variable data printing	5-1
Printing variable data documents with Fiery FreeForm	5-2
How Fiery FreeForm works	5-2
Creating the master document	5-3
Creating the variable document	5-4
Combining the FreeForm master with the variable document	5-5
Using Fiery FreeForm	5-7

Chapter 6: Scanning

Fiery Remote Scan components	6-1
Using Fiery Remote Scan	6-2
Retrieving scans using Fiery Remote Scan	6-2
Sending the scan job to a specific destination	6-4
Using WebScan	6-8
Retrieving Scans with WebScan	6-8

Chapter 7: Tracking and Monitoring Jobs

Accessing Fiery WebTools	7-1
Checking Fiery status with the Status WebTool	7-2
Accessing information with WebLink	7-3
Accessing PrintMe with the PrintMe WebTool	7-4

Chapter 8: Using Fiery E-mail Service

How Fiery E-mail Service works	8-1
Printing using an E-mail Client	8-2
Job Control	8-4
Printing using the E-mail Port Monitor	8-4

Appendix A: Print Options

About printer drivers and printer description files	A-1
Where to set print options	A-2
Print option override hierarchy	A-3
Default settings	A-3
More about print options	A-10

Appendix B: Font List

PostScript printer fonts	B-1
Adobe Type 1 fonts	B-1
TrueType fonts	B-6

Appendix C: Troubleshooting

Maintaining optimal system performance	C-1
Troubleshooting	C-1
General printing problems	C-2
Problems with print quality	C-4
Problems with Fiery Downloader	C-5
Problems with Fiery Scan	C-6
Problems with Fiery WebTools	C-6

Index

Introduction

The Fiery Network Controller for DocuColor 3535 is used to print final documents or proof jobs that will be printed later on an offset press. You can send a print job to the Fiery Network Controller for DocuColor 3535 as you would to any other printer—select it from the Printers dialog box on Microsoft Windows computers, or in the Chooser on Apple Mac OS computers, and then print from within any application.

NOTE: The term “Fiery” is used in this manual to refer to the Fiery Network Controller for DocuColor 3535 installed in the copier. The name “Aero” is used in illustrations to represent the Fiery. The term “Windows 9x” is used in this manual to refer to Windows 98. The term “Windows” is used in this manual to refer to Windows 9x/Me, Windows NT 4.0, and Windows 2000/XP.

Although it may not be the case at all sites, it is assumed that an operator controls and manages jobs sent by users from remote workstations. For information on the features of Command WorkStation, Fiery WebSpooler™, and Fiery Spooler™, see the *Job Management Guide*.

About this manual

This manual is intended for remote users who send jobs via the network and the Fiery. It covers the following topics:

- Printing from a Windows computer
- Printing from a Mac OS computer
- Printing from a UNIX workstation
- Downloading files and fonts using Fiery Downloader™ and Fiery WebDownloader™
- Printing variable data documents
- Using Fiery Remote Scan™ software
- Monitoring jobs and accessing information using Fiery WebTools™
- Printing using the Fiery E-mail Service
- Specifying and overriding job settings, generating a list of fonts installed on the Fiery, and troubleshooting information

1

Chapter 1: Printing from Windows Computers

This chapter describes printing to the Fiery from Windows computers. You can print from a networked Windows computer or a computer using Windows (WINS) printing. You can also save files to print at a remote location.

You can print from a Windows computer in many ways. You can download PostScript (PS), Encapsulated PostScript (EPS), Tagged Image File Format (TIFF), or Portable Document Format (PDF) files using Fiery Downloader, or print documents using the Fiery E-mail Service. For supported file versions, see the *User Software Installation Guide*.

For basic instructions and details on using Fiery Downloader, see [Chapter 4](#). For basic instructions on using the Fiery E-mail Service, see [Chapter 8](#).

NOTE: For information on setting up the Windows environment for printing with Windows servers connected to the Fiery, see the *Configuration Guide*. For information about connecting to the Fiery over the network, installing printer drivers, and installing Fiery® utilities, see the *User Software Installation Guide*.

Printing from applications

Once the Fiery printer driver is installed and set to the proper port, as described in the *User Software Installation Guide*, you can print directly from most Windows applications. Simply set the print options for the job and choose the Print command from within your application.

To achieve the best printing results from specific applications, see the *Color Guide* and the *Fiery Color Reference*.

1

Setting options and printing from Windows computers

To print from Windows computers, install the corresponding Adobe PostScript printer driver. The driver is included on the Fiery User Software CD.

Once the Adobe PostScript printer driver and printer description file (PPD) are installed, you can specify print settings for a particular job and print it to the Fiery. You can also set default print settings using the driver.

To print from Windows applications by connecting your computer to a print server via the network, a Novell NetWare, Windows NT 4.0, or UNIX server is required. For more information, see the *Configuration Guide*.

To print from Windows applications without connecting to a print server, you can use Server Message Block (SMB) printing. For more information, see the *User Software Installation Guide*.

The following procedures explain how to use the driver to specify print options. For information about specific print options, see [Appendix A](#).

NOTE: The following procedures use Windows 98 illustrations.

TO SET PRINT OPTIONS FOR A SPECIFIC WINDOWS PRINT JOB USING THE ADOBE POSTSCRIPT PRINTER DRIVER

1. **Choose Print in your application.**
2. **Select the Fiery as your printer and click Properties.**

1

1-3 Printing from applications

3. Click the Fiery Printing tab.

Job Templates, see page 1-7

Print option bars

Shortcuts, see page 1-12

Click to display all print options

Click to hide all print options

The Fiery Printing tab serves as the control center for all frequently used printing functions.

NOTE: Supported tabs and print options may vary between Windows 9x/Me, Windows NT 4.0, and Windows 2000/XP PostScript drivers. For a complete list of print options, see [Appendix A](#).

4. Click the ColorWise print option bar.

ColorWise

Brightness: 100% Normal

Print Mode: Standard Color, Expert Color, Grayscale

Combine Separations: On, Off

Screen Switching: On

1

1-4 Printing from Windows Computers

Specify the color profile options for the job.

In the Print Mode area, specify the color mode for the job. To use advanced color management features, such as Rendering Style, click Expert Settings and proceed to [step 5](#); otherwise, skip to [step 6](#).

5. In the Expert Color Settings dialog box, click Update to display the current Fiery settings.

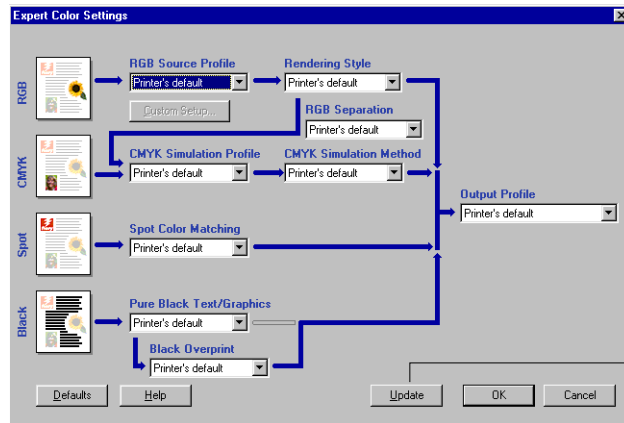

If Update does not appear, make sure Two-Way Communication is set up, as described in the *User Software Installation Guide*.

NOTE: Specify the color settings for the print job and click OK.

1

1-5 Printing from applications

6. Click the Owner Information print option bar.

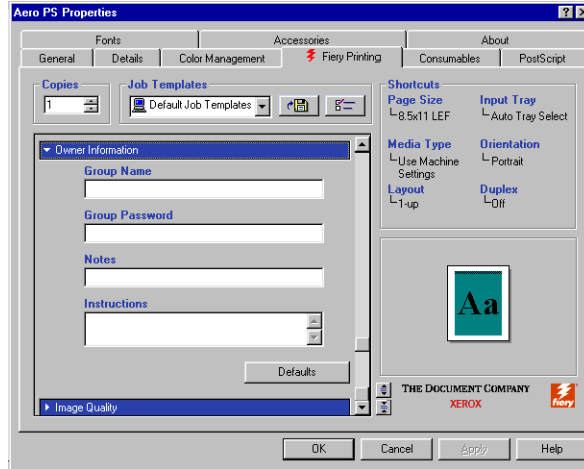

Enter the Group Name, Group Password, and text in the Notes area.

Enter user and job identification information for managing purposes, or whatever information is required at your site.

Enter the User ID in the Group Name field. The Group Name appears in Command WorkStation, WebSpooler, and Fiery Spooler, and also appears in the Job Log.

The Administrator or Operator can edit the Group Name and Group Password from the Command WorkStation, WebSpooler, or Fiery Spooler Properties windows.

The information you enter in the Notes field can be viewed by the operator in Command WorkStation and also appears in the Job Log. It *cannot* be edited or deleted by the operator.

For more information on Command WorkStation overrides, see the *Job Management Guide*.

7. In the Instructions area, enter instructions to the operator about the job.

These instructions can be displayed in Command WorkStation, but do not appear in the Job Log. These instructions *can* be edited by the operator.

8. Click the remaining print option bars to specify the appropriate settings for the print job and click OK.

These print options are specific to the Fiery and the copier. They override settings specified in Fiery Printer Setup, but can be overridden from the job management tools.

NOTE: The term “job management tools” is used in this manual to refer to Command WorkStation, Fiery Spooler, and WebSpooler.

For information about these options and overrides, see [Appendix A](#).

For information on configuring installable options, see the *User Software Installation Guide*.

For more information about job management tools, see the *Job Management Guide*.

If you choose Printer’s default, the job prints according to the settings specified in Setup. For more information, see [Appendix A](#).

NOTE: If paper loaded in the selected tray is a different size, orientation, or media type than that of the job you are sending, the Fiery displays an error message and the job fails to print. Load the correct paper in the selected tray or cancel the job.

NOTE: If you specify incompatible print settings, the Conflict dialog box provides instructions to resolve the conflict.

9. From your application, click OK.

Select the Fiery as your current copier.

10. Click OK.

1

1-7 Printing from applications

TO SET DEFAULT PRINT OPTIONS FOR ALL WINDOWS PRINT JOBS USING THE ADOBE POSTSCRIPT PRINTER DRIVER

1. Click Start, choose Settings, and then choose Printers.
2. Right-click the Fiery icon and choose Properties (Windows 9x/Me), Document Defaults (Windows NT 4.0), or Printing Preferences (Windows 2000/XP).

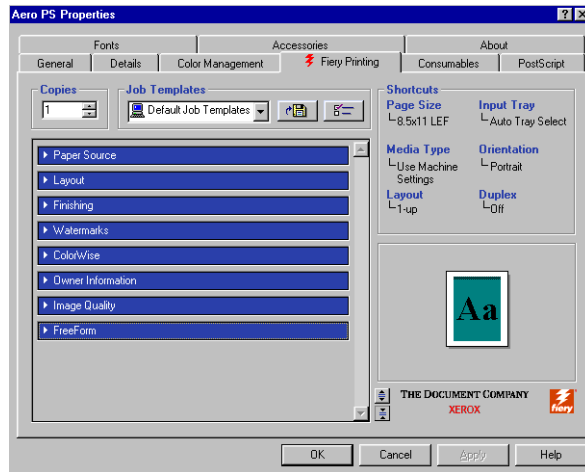

3. Specify the default settings for your print job, as described on [page 1-2](#).

NOTE:

Using job templates

You can save print option settings to your hard disk so you can easily load specifically configured settings for a particular job. You can also share job template files over a network, using the Import and Export features.

1

1-8 Printing from Windows Computers

TO CREATE JOB TEMPLATES

1. Make sure that Default Job Templates appear in the Job Templates menu, and then configure options from the print option bars.

As soon as you change any settings, the Job Templates menu displays Untitled instead of Default Job Templates.

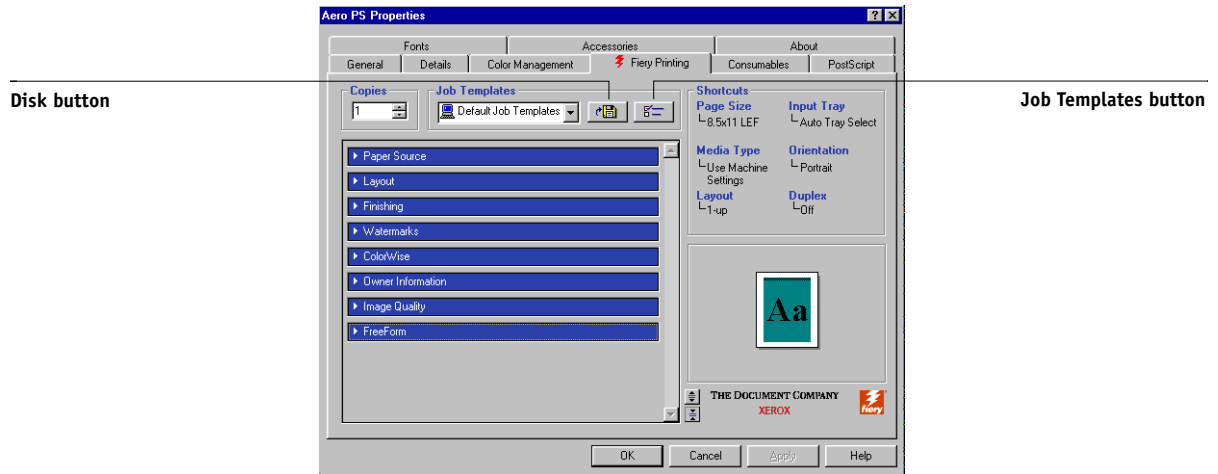

2. Click the Disk button.
3. Enter a Job Template name and click OK.

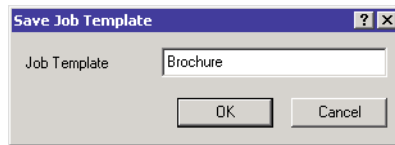

The name appears in the Job Templates menu.

1

TO LOAD JOB TEMPLATES

1. From the Fiery Printing tab, click the Job Template menu.
2. Choose the settings you want to use.

The options are automatically configured with the job template settings.

TO DELETE JOB TEMPLATES

1. From the Fiery Printing tab, click the Job Templates button.
2. Choose the settings you want to delete and click Delete.

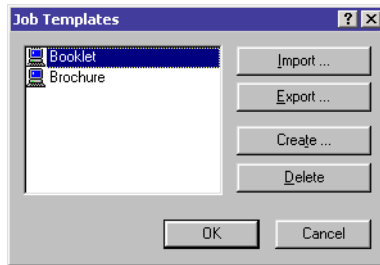

3. Click Yes to confirm the deletion and click OK.

TO MODIFY JOB TEMPLATES

1. From the Fiery Printing tab, click the Job Templates menu.
2. Choose the settings you want to modify.

The options are automatically configured with the currently saved job template.

3. Configure your new settings from the print option bars and click the Disk button.
4. Click OK to save the modified settings.

To EXPORT JOB TEMPLATES

1. From the Fiery Printing tab, click the Job Templates button.
2. Choose the Job Templates you want to export and click Export.

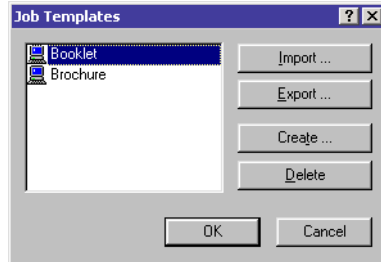

3. Browse to the location in which to save the file, enter a file name, and then click OK.

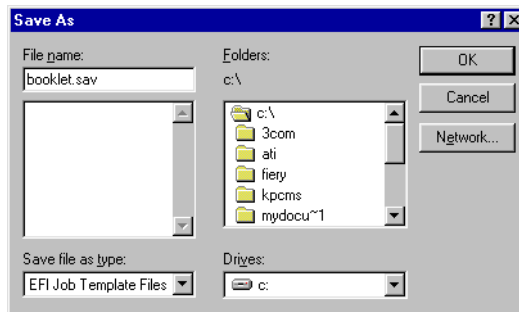

NOTE: The file name must include the .sav extension and can be up to eight characters (not including the extension). The file name does not have to match the Job Templates Name.

4. Click OK.

TO IMPORT JOB TEMPLATES

1. From the Fiery Printing tab, click the Job Templates button.
2. Click Import.
3. Browse to the location of the job template file you want to import.
4. Select the file and click OK.

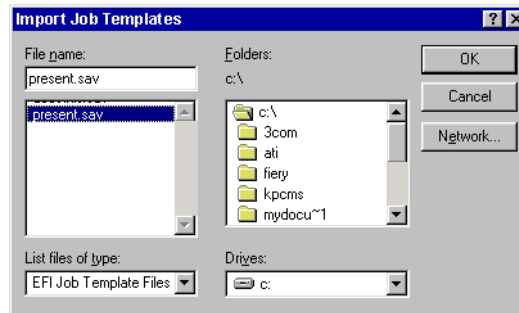

5. Click OK in the Job Templates dialog box.

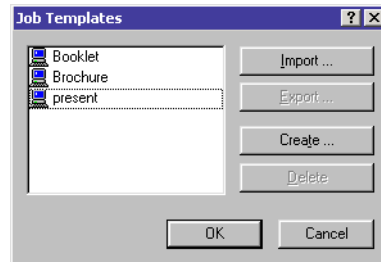

NOTE: When you import saved settings, they appear in the Job Templates menu under their Job Templates Name, not the file name. In the preceding examples, the file present.sav (file name) was imported, but it appears in the Job Templates menu as Presentation (Job Templates Name).

Using Shortcuts

The Shortcuts area of the driver interface displays the current settings for some of the most commonly used print options. You can access and change these settings quickly and easily using the Shortcuts. You can also access some page layout and finishing options by right-clicking the image of the page directly below Shortcuts.

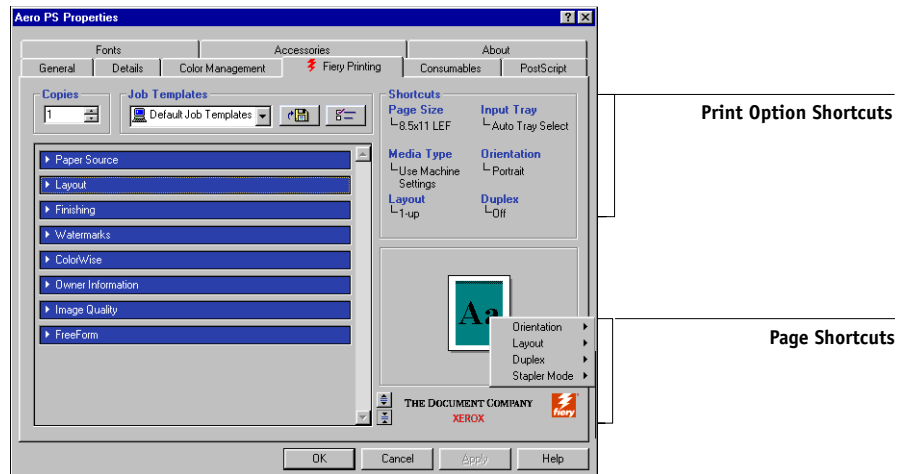

TO SET PRINT OPTIONS USING SHORTCUTS

1. From the Fiery Printing tab, position your cursor over the print option you want to set.

The cursor changes into a hand.

2. Click the selected print option and specify the appropriate settings.
Alternatively, right-click the print option and specify the settings directly.
3. Click Apply to make the new settings the default.
4. Click OK.

TO SET PRINT OPTIONS USING THE PAGE SHORTCUTS

1. From the Fiery Printing tab, click the Finishing tab, position your cursor over the page image, and then right-click.
2. Specify the appropriate settings for the print options.
3. Click Apply to assign the new settings as the default.
4. Click OK.

Defining and printing custom page sizes

When you create custom page sizes, specify Width dimensions to correspond with the shorter side of your job and specify Height dimensions to correspond with the longer side of your print job. Set custom page sizes this way, regardless of the orientation settings in the application.

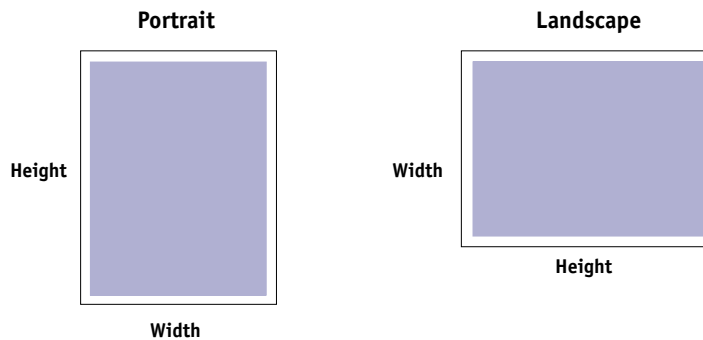

NOTE: Custom page sizes are not supported with Imposition jobs.

Working with custom page sizes in the Windows 9x/Me PostScript printer driver

With custom page sizes, you define the dimensions of a printed page. After you define a custom page size, you can use it from within an application without having to redefine it each time you print.

TO DEFINE A CUSTOM PAGE SIZE WITH THE WINDOWS 9X/ME POSTSCRIPT PRINTER DRIVER

1. Click Start, choose Settings, and then choose Printers.
2. Right-click the Fiery PS icon and choose Properties.
3. Click the Fiery Printing tab and click the Paper Source print option bar.
4. Click Custom.

Click Custom

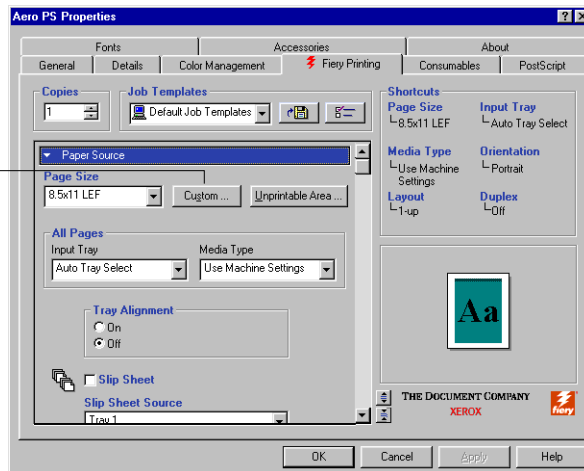

The Enter Custom Paper Size dialog box appears.

1

1-15 Defining and printing custom page sizes

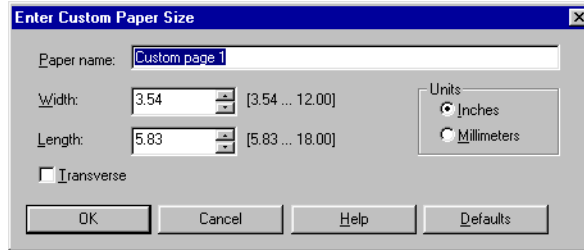

5. Specify options to define the custom page size.

Width—Enter the width of the print job.

Length—Enter the length of the print job.

Units—Select a unit of measurement for the print job.

Transverse—Select this option to swap Width and Length dimensions to correspond to the paper feed direction of the print job.

Paper name—Enter a name for your custom page size. The new custom paper name appears in the Document Size menu.

6. Click OK.

7. To define the unprintable area of the custom page, click Unprintable Area, enter the desired information, and then click OK.

8. Click OK again.

TO EDIT A CUSTOM PAGE SIZE WITH THE WINDOWS 9X/ME POSTSCRIPT PRINTER DRIVER

1. Click Start, choose Settings, and then choose Printers.
2. Right-click the Fiery PS icon and choose Properties.
3. Click the Fiery Printing tab and then click the Paper Source print option bar.



4. Choose the name of the custom page you want to edit from the Document Size menu.
5. Click Custom.
The Enter Custom Paper Size dialog box appears.
6. Edit the settings, as described on [page 1-15](#), and click OK.

**TO PRINT A CUSTOM PAGE SIZE WITH THE WINDOWS 9x/ME
POSTSCRIPT PRINTER DRIVER**

1. Choose Print from your application.
2. Select the Fiery PS icon as the printer and click Properties.
3. Click the Fiery Printing tab, and then click the Paper Source print option bar.
4. Select Tray 5 (Bypass) from the Paper Source menu.
5. Select the custom page size from the Page Size menu.
6. Click the Layout print option bar and specify Landscape for Orientation.
7. Click OK, and then click OK again to print the job.

1

Working with custom page sizes in the Windows NT PostScript printer driver

With custom page sizes, you define the dimensions of a printed page. After you define a custom page size, you can use it from within an application without redefining it each time you print.

NOTE: The copier must be set to print custom page sizes.

TO DEFINE A CUSTOM PAGE SIZE WITH THE WINDOWS NT 4.0 POSTSCRIPT PRINTER DRIVER

1. Click **Start**, choose **Settings**, and then choose **Printers**.
2. Right-click the **Fiery PS** icon and choose **Document Defaults**.
3. Click the **Page Setup** tab.
4. Choose **PostScript Custom Page Size** from the **Paper Size** menu.

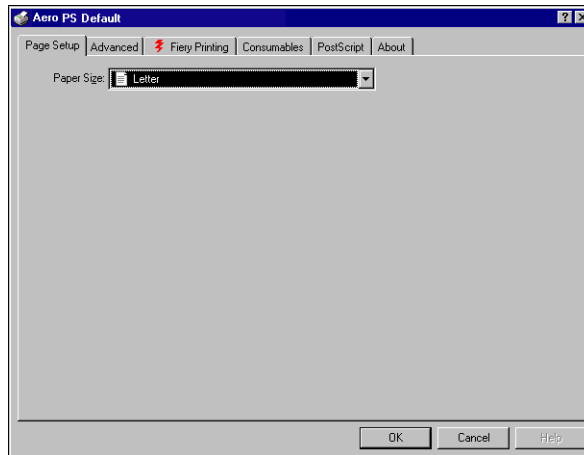

The PostScript Custom Page Size Definition dialog box appears.

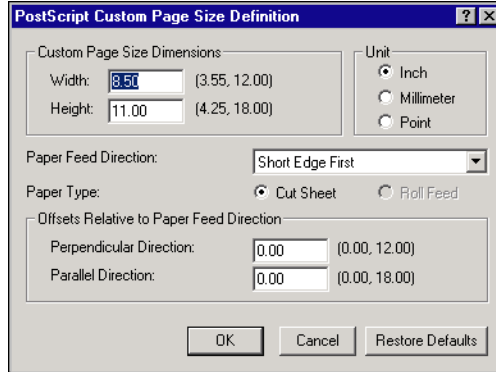

5. Specify options to define the custom page size.

Custom Page Size Dimensions—Enter the width and height of the print job.

Unit—Select a unit of measurement for the print job.

Paper Feed Direction—Choose the paper feed direction of the print job.

Paper Type—Select the type of paper for the print job.

Offsets Relative to Paper Feed Direction—Enter the offsets (margins) of the print job relative to the paper feed direction.

6. Click OK.

**TO EDIT A CUSTOM PAGE SIZE WITH THE WINDOWS NT 4.0
POSTSCRIPT PRINTER DRIVER**

1. Click Start, choose Settings, and then choose Printers.
2. Right-click the Fiery PS icon and choose Document Defaults.

1

1-19 Defining and printing custom page sizes

3. Click the **Advanced** tab and select **Paper Size** from the **Paper/Output** settings.

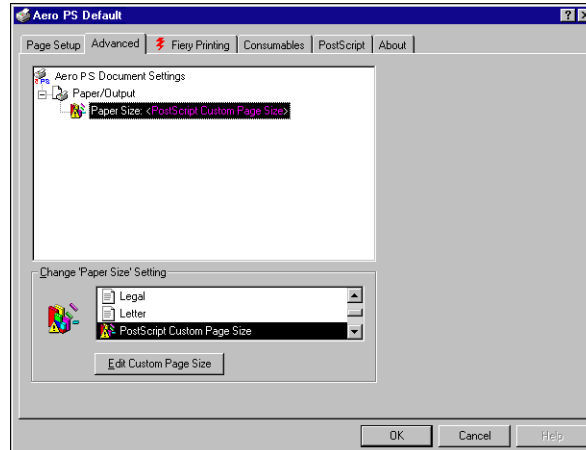

4. Choose **PostScript Custom Page Size**.

The PostScript Custom Page Size Definition dialog box appears. If it does not appear, click **Edit Custom Page Size**.

5. Edit the settings, as described on [page 1-18](#), and click **OK**.

TO PRINT A CUSTOM PAGE SIZE WITH THE WINDOWS NT 4.0 POSTSCRIPT PRINTER DRIVER

1. Choose **Print** from your application.
2. Select the **Fiery PS** as the printer and click **Properties**.
3. Choose **PostScript Custom Page** from the **Document Size** menu.
4. Click the **Fiery Printing** tab again, and specify **Landscape** for **Orientation** in the **Layout** print option bar.
5. Click **OK** and then click **OK** again to print the job.

Working with custom page sizes in the Windows 2000/XP PostScript printer driver

With custom page sizes, you define the dimensions of a printed page. After you define a custom page size, you can use it from an application without redefining it each time you print.

NOTE: Windows 2000 and Windows XP have a similar interface when setting options and printing. The following procedures use Windows 2000 illustrations, with Windows XP differences noted.

TO DEFINE A CUSTOM PAGE SIZE WITH THE WINDOWS 2000/XP POSTSCRIPT PRINTER DRIVER

1. Click **Start**, choose **Settings**, and then choose **Printers**.
2. Right-click the **Fiery PS** icon and choose **Printing Preferences**.
3. Click the **Paper/Quality** tab.
4. Click **Advanced**.

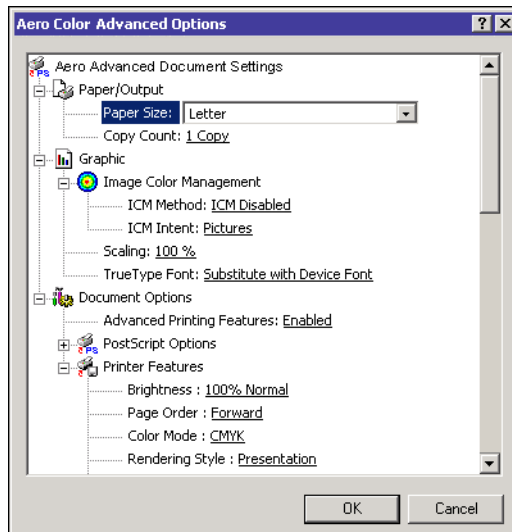

5. Choose PostScript Custom Page Size from the Paper Size menu.

The PostScript Custom Page Size Definition dialog box appears.

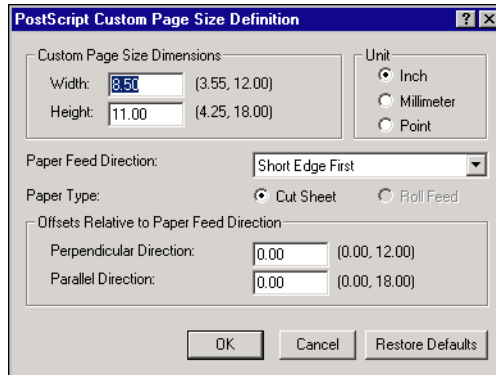
**6. Specify options to define the custom page size.**

Custom Page Size Dimensions—Enter the width and height of the print job.

Unit—Select a unit of measurement for the print job.

Paper Feed Direction—Choose the paper feed direction of the print job.

Paper Type—Select the type of paper for the print job.

Offsets Relative to Paper Feed Direction—Enter the offsets (margins) of the print job relative to the paper feed direction.

7. Click OK to close the PostScript Custom Page Size Definition dialog box.**8. Click OK to close the Advanced Options dialog box.****9. Click OK to close the Printing Preferences dialog box.**

You can now specify the custom page size from an application.

**TO EDIT A CUSTOM PAGE SIZE WITH THE WINDOWS 2000/XP
POSTSCRIPT PRINTER DRIVER**

- 1. Click Start, choose Settings, and then choose Printers.**
- 2. Right-click the Fiery PS icon and choose Printing Preferences.**
- 3. Click the Paper/Quality tab.**

4. **Click Advanced.**
5. **Choose PostScript Custom Page Size from the Paper Size menu.**

The PostScript Custom Page Size Definition dialog box appears. If it does not appear, click Edit Custom Page Size.
6. **Edit the settings, as described on [page 1-21](#), and click OK.**

TO PRINT A CUSTOM PAGE SIZE WITH THE WINDOWS 2000/XP POSTSCRIPT PRINTER DRIVER

1. **Choose Print from your application and select Properties.**
2. **Click the Paper/Quality tab.**
3. **Click Advanced.**
4. **Choose PostScript Custom Page Size from the Paper Size menu.**
5. **Verify the custom page size settings and click OK.**
6. **Select Manual Bypass Tray from the Paper Source menu.**
7. **Click OK to close the Advanced Options dialog box.**
8. **Click the Layout tab, specify Landscape for Orientation, and then click Apply.**
9. **Click OK to close the Printing Preferences dialog box.**
10. **Click Print.**

Saving files to print at a remote location

If you do not have a Fiery onsite, and are preparing files to take to a service bureau or other location, print the final files to the File port (as opposed to one of the local ports). You can also print to the File port to create a file to download using Fiery Downloader. For instructions on printing to the File port, see your Windows documentation.

Chapter 2: Printing from Mac OS Computers

You can print to the Fiery just as you would print to any other printer from any application. If you are using Mac OS 9 and earlier or Mac OS X (Classic mode), select the Fiery as the current printer in the Chooser, and then print the file from within the application. If you are using Mac OS X (Native mode), you can choose the printer and print the file from within the application.

Another way to print from a Mac OS computer is to download PostScript (PS), Encapsulated PostScript (EPS), Tagged Image File Format (TIFF), or Portable Document Format (PDF) files using Fiery Downloader. For supported file versions, see the *User Software Installation Guide*. For details on using Fiery Downloader, see [Chapter 4](#).

Printing from applications with Mac OS 9 and earlier or Mac OS X (Classic mode)

Before you can print to the Fiery from applications, you must select the Fiery in the Chooser. Then, using the Adobe PostScript printer driver and the correct printer description file, you can control many Fiery printing features by specifying job settings from print dialog boxes.

To achieve the best printing results from specific applications, see the *Color Guide* and the *Fiery Color Reference*.

Selecting the Fiery in the Chooser

Before you print a job, make sure the Fiery is the currently selected printer.

NOTE: For information about setting up the Fiery in the Chooser, see the *User Software Installation Guide*.

TO SELECT THE FIERY AS THE CURRENT PRINTER

1. **Make sure the Fiery is connected to the network and turned on.**
2. **Choose Chooser from the Apple menu.**

3. Click the AdobePS icon to select it.

NOTE: Make sure AppleTalk is set to Active.

4. If your network is divided into zones, select the zone in which the Fiery is located.

5. Select the Fiery by <Server Name>_<Queue Name>_ from the “Select a PostScript Printer” list.

The names of all supported printers in the zone appear.

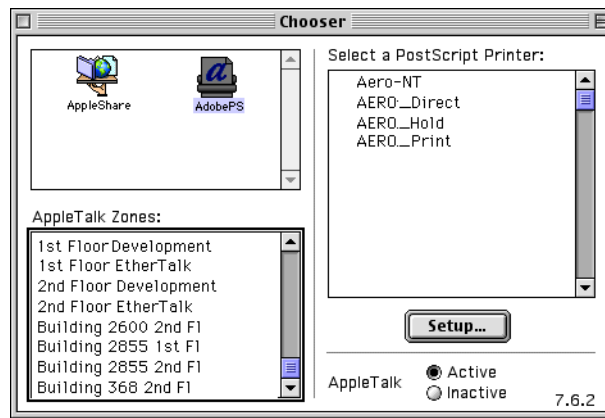

NOTE: If your system administrator has not enabled the connection to the Print queue or the Direct connection, the corresponding names will *not* appear in this list. For example, if your site has an operator who controls the flow of print jobs from Command WorkStation, you may be able to print only to the Hold queue. For more information on enabling print connections, see the [Configuration Guide](#).

6. Close the Chooser window.

The Fiery remains selected as the current printer until you select a new printer in the Chooser.

Setting options and printing from Mac OS 9 and earlier or Mac OS X (Classic mode) computers

In Mac OS applications, print options are set from both the Page Setup dialog box and the Print dialog box. For details on specific print options, see [Appendix A](#).

NOTE: Some default print options are set by the administrator during Setup. Contact the administrator or the operator for information on the current server default settings.

TO SET PRINT OPTIONS AND PRINT WITH THE ADOBEPS PRINTER DRIVER

1. Open a file and choose Page Setup from the application's File menu.
2. Choose Page Attributes in the dialog box that appears.

Select the Fiery as your printer.

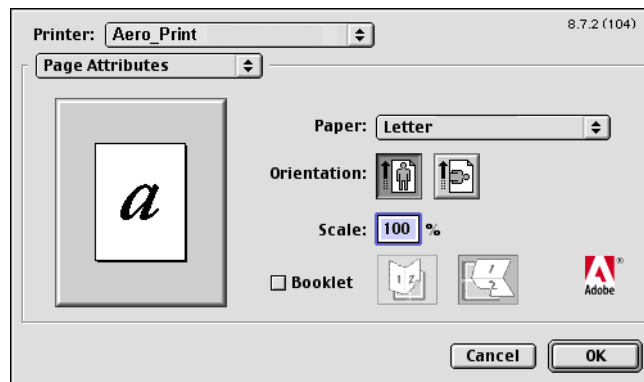

NOTE: Page Setup dialog boxes vary across applications.

3. Select the Page settings for your print job.
4. Click OK.

5. Choose Print from the application's File menu.
6. Select the Fiery as your printer and specify settings for the print options displayed.

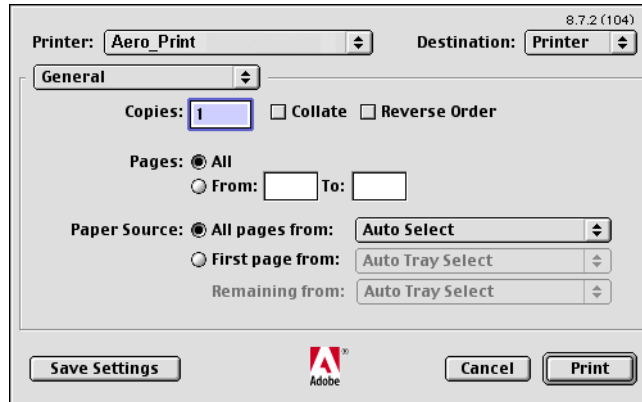

NOTE: Print dialog boxes vary across applications.

From the Paper Source menu, choose the paper tray for the job. For example, you can specify that the job be printed on paper in Tray 1.

The Paper Source selection is valid for the current job only.

NOTE: If paper loaded in the selected tray is a different size, orientation, or media type than that of the job you are sending, the Fiery displays an error message and the job fails to print. Load the correct paper into the selected tray or cancel the job.

7. Choose Fiery Job Notes.

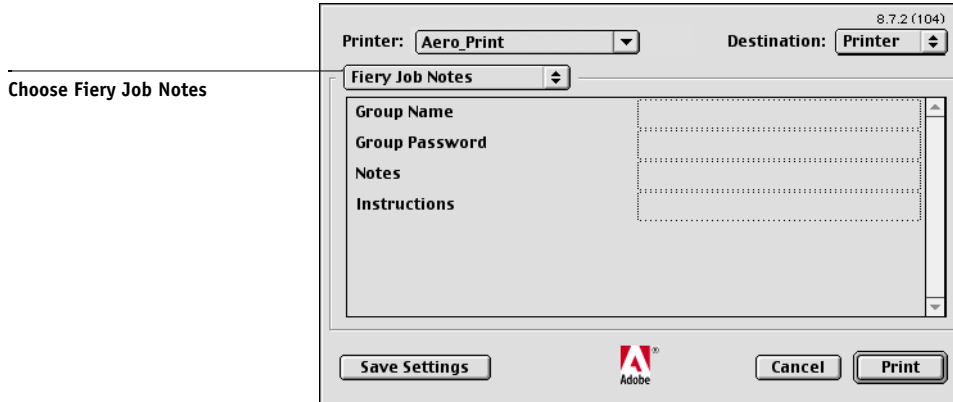

Enter user and job identification information for managing purposes, or whatever information is required at your site.

Enter the User ID in the Group Name field. The Group Name appears in Command WorkStation, WebSpooler, and Fiery Spooler, and also appears in the Job Log.

The Administrator or Operator can edit the Group Name and Group Password from the Command WorkStation, WebSpooler, or Fiery Spooler Properties window.

The information you enter in the Notes field can be viewed by the operator in Command WorkStation and also appears in the Job Log. It *cannot* be edited or deleted by the operator.

NOTE: Group Name and Group Password options are not available when printing to the Direct connection.

For more information on Command WorkStation overrides, see the *Job Management Guide*.

8. Choose Printer Specific Options and specify the appropriate settings for your print job.

Choose Printer Specific Options

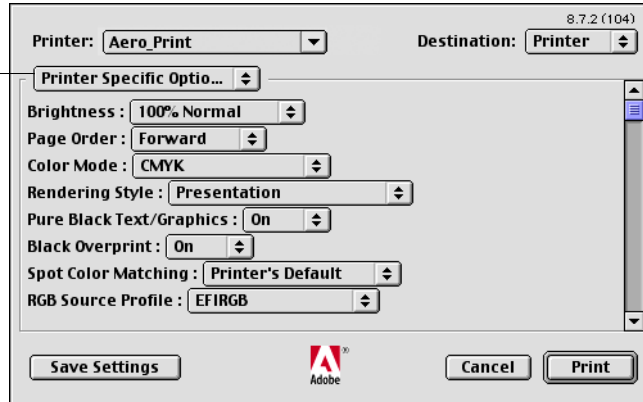

These print options are specific to the Fiery and the copier; you may have to scroll to see all the options. They override settings in Fiery Printer Setup, but can be changed from Command WorkStation, Fiery WebSpooler, or Fiery Spooler.

If you choose Printer's default, the job prints according to the settings specified in Setup.

For more information about these options and overrides, see [Appendix A](#).

Some print options, including Soft Collate, Soft Reverse Order, and Manual Duplex that are selectable from an application or Adobe PS printing, are similar to the print options available from the Printer Specific Options menu. In these cases, specify the print option from the Printer Specific Options menu. The application or Adobe PS printer driver may not set up the file properly for printing on the Fiery, which may cause an unexpected printing error and take longer to process.

You can set some print options from an application (for example, Reverse Order Printing or Collation). In these cases, use the print option to perform the function, rather than setting it from the application. The application may not set up the file properly for printing on the Fiery and take longer to process.

NOTE: If you specify incompatible print settings, a dialog box might appear. Follow the on-screen instructions to resolve the conflict.

9. To make the new settings the default settings, click Save Settings.
10. Click Print.

Defining custom page sizes

With custom page sizes, you can define page dimensions and margins. After you define a custom page size, you can use it from within an application without redefining it each time you print.

TO DEFINE A CUSTOM PAGE SIZE

1. Choose Page Setup from the application's File menu.
2. For Paper, choose Custom.
3. Choose Custom Page Default.
4. Enter the page dimensions and margins.
5. To view the minimum and maximum sizes, click the PPD Limits menu.

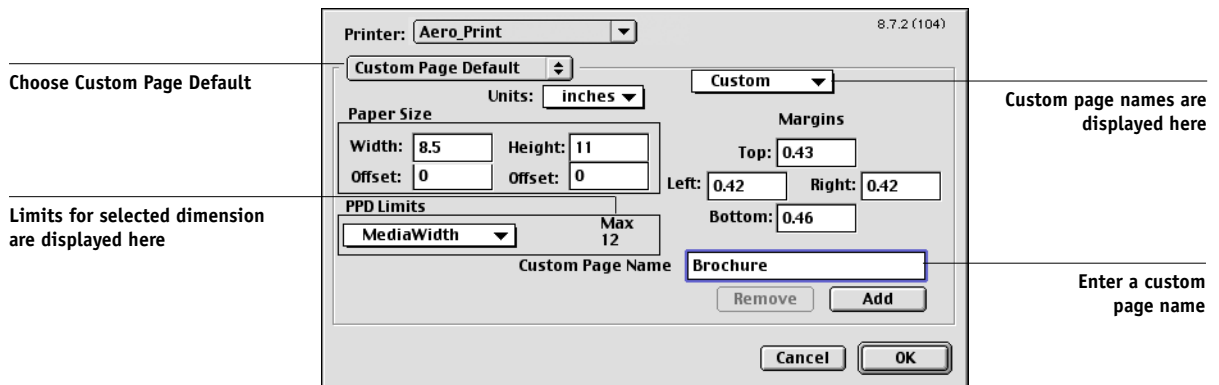

If you enter invalid sizes, an error message appears. Click Cancel and enter sizes specified within the PPD Limits.

2

6. **To save this custom page size, enter a name and click Add.**

Saved custom page sizes appear in the menu of page sizes in the upper-right corner of the dialog box. To remove a saved custom page size, choose it from the menu and click Remove.

7. **Click OK.**

TO EDIT A SAVED CUSTOM PAGE SIZE

1. **Choose Page Setup from the application's File menu.**
2. **Choose Custom Page Default.**
3. **Select the Custom Page Size name.**
4. **Edit the page dimensions and margins.**
5. **Click Add.**
6. **Replace the existing Custom Page name and click OK.**

TO PRINT A CUSTOM PAGE SIZE

1. **Choose Page Setup from the application's File menu.**
2. **Choose Custom or the Custom Page Size name from the Paper menu.**
3. **Click OK.**
4. **Choose Print from your application's File menu.**
Specify your printing options.
5. **Click Print.**

Printing from applications with Mac OS X (Native mode)

Once you install the Fiery printer description files using the PPD Installer, you will be able to print directly from most Mac OS X applications. For more information about installing printer description files with the PPD Installer see, the *User Software Installation Guide*.

To achieve the best printing results from specific applications, see the *Color Guide* and the *Fiery Color Reference*.

Setting options and printing from Mac OS X (Native mode)

In Mac OS X applications, print options are set from both the Page Setup dialog box and the Print dialog box. For details on specific print options, see [Appendix A](#).

NOTE: Some default print options are set by the administrator during Setup. Contact the administrator or the operator for information on the current server default settings.

TO SET OPTIONS AND PRINT WITH THE ADOBEPS PRINTER DRIVER

1. Open a file and choose Page Setup from the application's File menu.
2. In the dialog box that appears, choose Page Attributes for Settings and the Fiery for Format for as your printer.

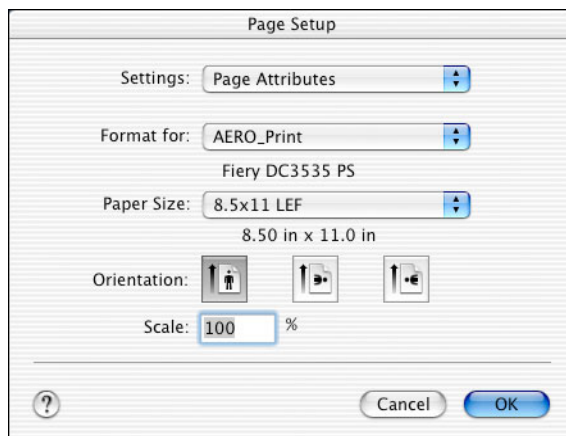

3. Select the Page settings for your print job.
4. Click OK.
5. Choose Print from the application's File menu.
6. Select the Fiery as your printer and choose an option category from the pop-up menu.

You can change the print option settings for each category.

Choose print categories

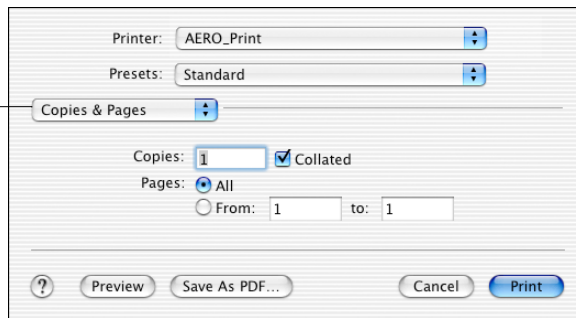

7. Choose Printer Features and specify the appropriate settings for your job.

Choose print categories

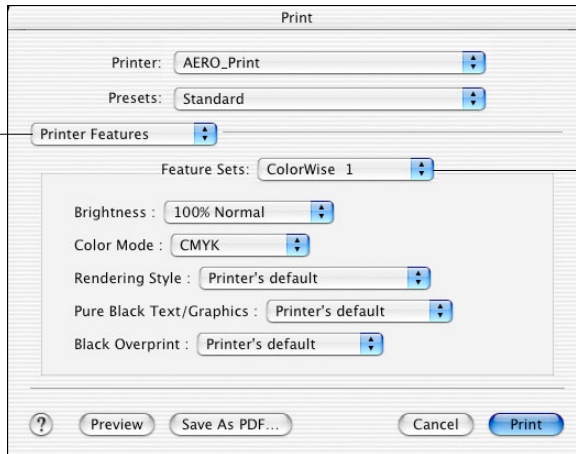

Choose a specific Feature Set category

These print options are specific to the Fiery and the copier; you will have to choose specific Feature Set categories to see all the options. They override settings in Fiery Printer Setup, but can be changed from Command WorkStation, Fiery WebSpooler, or Fiery Spooler.

If you choose Printer's default, the job prints according to the settings specified in Setup.

For more information about these options and overrides, see [Appendix A](#).

Some print options, including Soft Collate, Soft Reverse Order, and Manual Duplex that are selectable from an application or Adobe PS printing, are similar to the print options available from the Printer Features menu. In these cases, specify the print option from the Printer Features menu. The application or Adobe PS printer driver may not set up the file properly for printing on the Fiery, which may cause an unexpected printing error and take longer to process.

You can set some print options from an application (for example, Reverse Order Printing or Collation). In these cases, use the print option to perform the function, rather than setting it from the application. The application may not set up the file properly for printing on the Fiery and take longer to process.

NOTE: If you select an invalid setting or combination of settings when printing a document, no error message will appear. For example, you may be able to select duplex printing on transparency media. Invalid settings and combinations will be ignored by the Fiery.

NOTE: Group Password, Group Name, Notes, and Information cannot be entered with Mac OS X (Native mode).

8. Click Print.

Defining custom page sizes

With custom page sizes you can define page dimensions and margins. After you define a custom page size, you can use it from within an application without redefining it each time you print.

TO DEFINE A CUSTOM PAGE SIZE

1. Choose **Page Setup** from the application's **File** menu.
2. For **Settings**, choose **Custom Paper Size**.

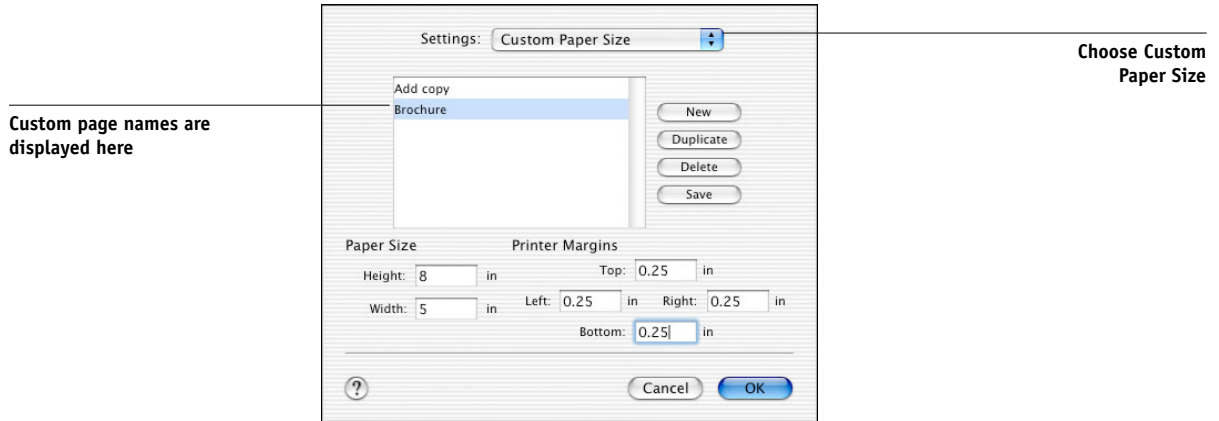

3. Click New and enter a name for the custom page size.
4. Enter the page dimensions and margins.
5. Click Save.
6. Click OK to exit.

TO EDIT A SAVED CUSTOM PAGE SIZE

1. Choose Page Setup from the application's File menu.
2. For Settings, choose Custom Paper Size.
3. Select the Custom Page Size name.
4. Edit the page dimensions and margins.
5. Replace the existing Custom Page name by clicking on it.
6. Click Save.
7. Click OK to exit.

TO DELETE A CUSTOM PAGE SIZE

1. Choose Page Setup from the application's File menu.
2. For Settings, choose Custom Paper Size.
3. Click the Custom Paper Size name.
4. Click Delete.
5. Click OK to exit.

TO MAKE A COPY OF THE CUSTOM PAGE SIZE

1. Choose Page Setup from the application's File menu.
2. For Settings, choose Custom Paper Size.
3. Click the Custom Paper Size name.
4. Click Duplicate.
5. Click OK to exit.

Chapter 3: Printing from UNIX Workstations

You can print to the Fiery directly from UNIX workstations. Jobs printed to the Fiery are sent to the Print or Hold queues and can be manipulated from Command WorkStation, or from Windows and Mac OS computers on the network using Fiery WebSpooler or Fiery Spooler.

NOTE: If you print to the Hold queue, an operator must intervene from Command WorkStation, Fiery Spooler, or Fiery WebSpooler for the job to print; jobs sent to the Hold queue are spooled to disk and held.

For more information on using Command WorkStation, Fiery Spooler, or Fiery WebSpooler, see the *Job Management Guide*.

The queue name and Fiery printer name are determined by your system administrator. Contact your system administrator for the names of your queues.

For information about setting up printing from TCP/IP, see your UNIX system documentation.

Printing to the Fiery

You can use UNIX commands to print PostScript and text files to the Fiery. In general, use basic print commands (`lpr`, `lpq`, `lprm`) to send print jobs to the Fiery. For information about UNIX commands, see the UNIX manual pages or other documentation.

NOTE: Only PostScript and ASCII text files can be printed from UNIX.

TO PRINT FROM UNIX

- **On a system running SunOS 4.1.x or another BSD-based variant, use the `lpr` command to send a job to the Fiery, as follows:**

```
lpr <-Pprinter> <#copies> <filename>
```

For example, if the Print queue of your Fiery is named `print_Server`, your file is named `Sample`, and you want to print two copies, type:

```
lpr -Pprint_Server -#2 Sample
```

- **On a system running Solaris 2.x or any System V implementation of UNIX, use the `lp` command to send a job to the Fiery, as follows:**

```
lp -d <printername> -n <copies> <filename>
```

For example, if the Print queue of your Fiery is named `print_Server`, your file is named `Sample`, and you want to print two copies, type:

```
lp -d print_Server -n 2 Sample
```

TO DISPLAY A LIST OF JOBS IN THE QUEUE

- **On a system running SunOS 4.1.x or another BSD-based variant, use the `lpq` command to see printer jobs in the queue, as follows:**

```
lpq <-Pprinter>
```

For example, if the Print queue of your Fiery is named `print_Server`, type:

```
lpq -Pprint_Server
```

Your workstation displays the contents of the queue.

- **On a system running Solaris 2.x or any System V implementation of UNIX, use the `lpstat` command to see printer jobs in the queue, as follows:**

```
lpstat -o <printername>
```

For example, if the Print queue of your Fiery is named `print_Server`, type:

```
lpstat -o print_Server
```

Your workstation displays the contents of the queue.

TO REMOVE JOBS FROM THE QUEUE

NOTE: Unless you log in as the root user, you can remove only your own jobs.

- **On a system running SunOS 4.1.x or another BSD-based variant, use the `lprm` command to remove jobs from the queue, as follows:**

```
lprm <-Pprinter> <job #...>
```

You can use the `lpq` command to check the job number.

For example, to remove job number 123 from the Print queue of your Fiery named `print_Server`, type:

```
lprm -Pprint_Server 123
```

The `lprm` command reports the names of any files it removes.

- **On a system running Solaris 2.x or any System V implementation of UNIX, use the `cancel` command to remove jobs from the queue.**

```
cancel <printername> <job ID>
```

For example, to remove job number 123 from the Print queue of your Fiery named `print_Server`, type:

```
cancel print_Server 123
```

Chapter 4: Downloading Files and Fonts

Fiery Downloader and WebDownloader allow you to send PostScript (PS), Encapsulated PostScript (EPS), Tagged Image File Format (TIFF), and Portable Document Format (PDF) files directly to the Fiery without using the application in which the files were created. These utilities also allow you to manage printer fonts on the Fiery.

You can use Fiery Downloader or WebDownloader from a remote workstation. Fiery Downloader and Fiery WebDownloader require a network connection. For information on installing and configuring Fiery Downloader and WebDownloader on supported networking protocols, see the *User Software Installation Guide*.

NOTE: The Windows and Mac OS version of Fiery Downloader and WebDownloader are fundamentally the same; differences are noted in this chapter. Where both windows or dialog boxes are illustrated, the Windows version comes first, followed by the Mac OS version.

You can also download files and fonts by using the Import feature in Command WorkStation. For more information, see the *Job Management Guide*.

Using Fiery Downloader or WebDownloader

You can use Fiery Downloader to do the following:

- Check the status of the Fiery.

NOTE: This function is not available using WebDownloader, but is available through the Status WebTool.

- Print PostScript, EPS, TIFF, and PDF files to the Fiery.
- Manage the printer fonts stored on the Fiery hard disk (this feature requires that the Direct connection be published on the Fiery).

NOTE: Fiery Downloader and WebDownloader are designed specifically for the Fiery; you cannot use them with any other printer.

TO VIEW INFORMATION WITH FIERY DOWNLOADER

1. Double-click the Fiery Downloader icon or choose Fiery Downloader from the Start > Programs menu.
2. Select the Fiery in the Chooser window and click OK (Windows) or Connect (Mac OS).

The Fiery Downloader Status window appears, displaying the Fiery Downloader toolbar, menus, and status bar.

Displays server status and user and document name of the job currently printing

Displays server status and user and document name of the job currently processing

Dynamically displays the progress of the job

Displays the amount of available disk space

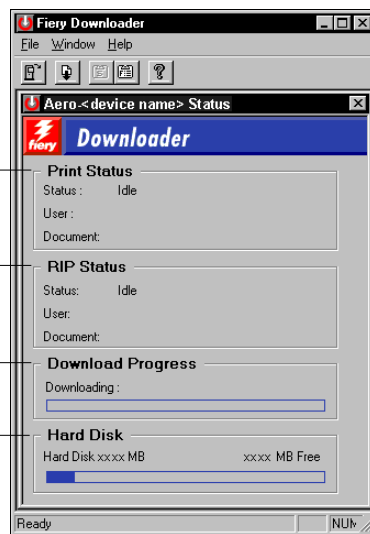

4

4-3 Using Fiery Downloader or WebDownloader

Buttons for some menu functions appear in the toolbar at the top of the window.



Open

Click to connect to a different Fiery.



Download

Click to download a file or font to the Fiery.



Status

If you are viewing the Font List, click to display the status window for the current Fiery.



Font List

If you are viewing the status window, click to display a list of printer fonts on the Fiery hard disk.



About Fiery
Downloader
(Windows only)

Click to view version information about
Fiery Downloader.

3. **To view font information in the window, choose Font List from the File menu, or click the Font List button.**
4. **To select a different Fiery, choose Open from the File menu or click the Open button.**
5. **Select the Fiery in the dialog box that appears and click OK (Windows) or Connect (Mac OS).**
6. **To close the Fiery Downloader dialog box, choose Close from the File menu. To quit Fiery Downloader, choose Exit (Windows) or Quit (Mac OS) from the File menu.**
7. **Click Download.**

Downloading printer fonts

You can download a variety of file types, as well as fonts, to the Fiery. You can specify a limited number of print option settings for the files you download.

TO DOWNLOAD A FILE OR FONT WITH FIERY DOWNLOADER

1. Use your application to generate a file.

You can save a PostScript or PDF file by selecting the appropriate option in the application's Print dialog box. With some applications, you can also save EPS and TIFF files.

If you experience problems printing EPS files with Fiery Downloader, print the file directly from the application in which you created it.

2. Start Fiery Downloader.

3. Choose Download from the File menu or click the Download button.

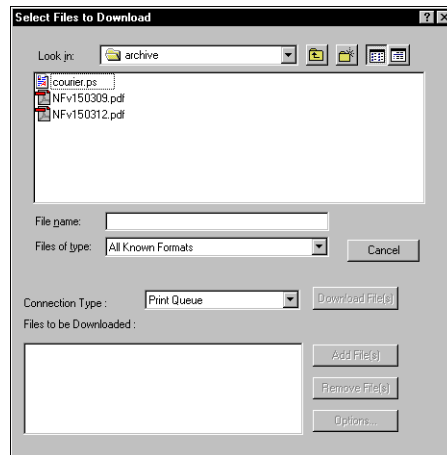

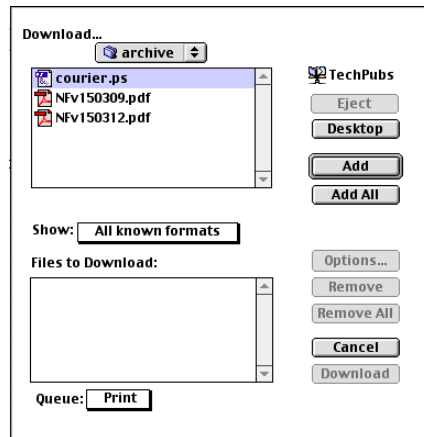

4. Choose the file type to display from the Files of type (Windows) or Show (Mac OS) menu.

All Known Formats lists all files in formats supported by Fiery Downloader.

You can download files and fonts in the same batch. If the fonts are used by files in the same batch, the fonts download first.

5. Choose the Connection Type (Windows) or Queue (Mac OS) to which you will download the files.

The options available depend on the setup at your site. The potential selections are Print Queue (Windows) or Print (Mac OS), Hold Queue (Windows) or Hold (Mac OS), and Direct Connection (Windows) or Direct (Mac OS). If your administrator has not enabled one or more of these connections, you cannot select it.

You cannot print PDF or TIFF files with the Direct connection. If you choose the Direct connection, the job is spooled to the Print queue and then printed. If the Print queue is not enabled, the job is spooled to the Hold queue and must be released for printing by the operator.

NOTE: To download fonts, you must use the Direct connection (make sure the Direct connection is published on the Fiery). If you do not have access to the Direct connection, you must embed any special fonts used by the file in the file when you generate it.

6. Select the file name and click Add File(s) (Windows) or Add (Mac OS).

The File name field (Windows) displays the name of the selected file before you click Add.

You can navigate to different drives and directories to select files to download. Click Add All (Mac OS) to add all files in a folder.

To select multiple sequential files (Windows), select the first file and then Shift-click the last file. Control-click to select multiple non-sequential files.

To remove a file, select the file name in the Files to Download list and click Remove File(s) (Windows) or Remove (Mac OS).

Click Remove All (Mac OS) to remove all files from the Files to Download list.

7. To change the attributes of a file to be downloaded, select the file and click Options.

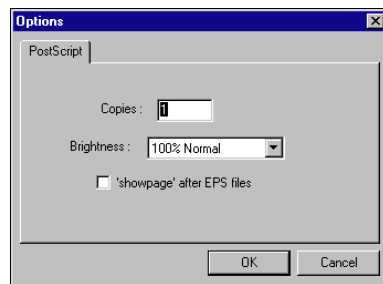

PostScript Options dialog box (Windows)

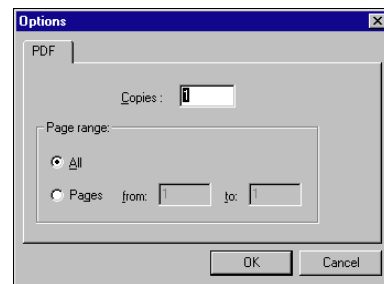

PDF Options dialog box (Windows)

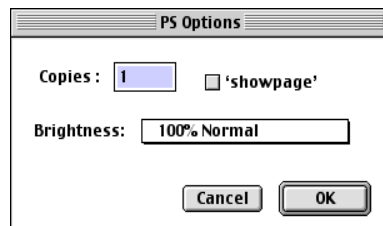

PostScript Options dialog box (Mac OS)

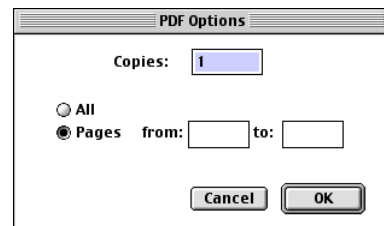

PDF Options dialog box (Mac OS)

8. Specify the following information in the dialog box and click OK.

The options you set apply only to the selected file. You can set different options, or leave the default settings, for each file.

Copies—Enter the number of copies.

Brightness (PostScript and EPS files only)—Change the Brightness setting if a file appears to be too dark or too light. Choose 85% for a substantially lighter image, 115% for a substantially darker image, or one of the options in between.

NOTE: Some applications, including Adobe Photoshop, provide transfer functions that allow you to specify density settings for an image. If the file you are printing includes transfer functions, the Fiery Downloader Brightness option has no effect. For more information on using transfer functions, see the documentation for your application.

‘showpage’ after EPS files (Windows) or **‘showpage’** (Mac OS) (PostScript and EPS files only)—In most cases, you do not need to use this option. Select the ‘showpage’ option only if an EPS file fails to print without it. This option adds a ‘showpage’ PostScript language command at the end of the print job. Some applications omit this necessary PostScript language command when they generate EPS files. Select this option when printing EPS files generated by these applications. If you select this option unnecessarily, extra blank pages may print.

If you experience problems printing EPS files with Fiery Downloader, you can print the file directly from the application in which you created it.

Page range (PDF files only)—Specify the page range you want to print.

9. **Click Download File(s) (Windows) or Download (Mac OS).**
10. **To cancel downloading, press Escape (Windows) or Command-. (Mac OS).**

TO CREATE A FONT BACKUP

1. **Start Fiery Downloader.**
2. **Choose Back up fonts from the File menu.**

4

4-8 Downloading Files and Fonts

3. Browse to the location in which to save the fonts.

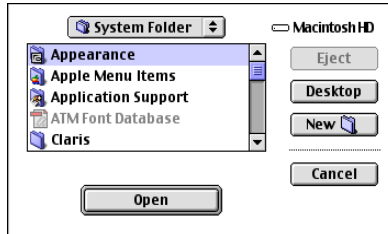
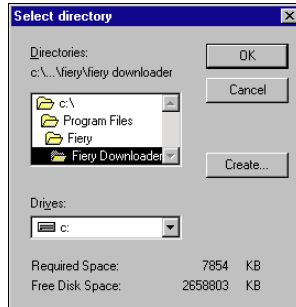

You can create a new directory by clicking Create (Windows) or New Folder (Mac).

4. Click OK.

The font backup file is saved.

TO RESTORE FONTS

1. Start Fiery Downloader.
2. Choose Restore fonts from the File menu.
3. Open the font backup file from the saved location, and click OK (Windows) or Select this folder (Mac),

This replaces all the user fonts on the Fiery.

TO DOWNLOAD FILES OR FONTS USING WEBDOWNLOADER**1. Create a PostScript, EPS, TIFF, or PDF file.**

Specify the appropriate print options, and include (embed) any necessary fonts that are not resident on the Fiery. For a list of fonts resident on the Fiery, see [Appendix B](#).

2. Start Fiery WebTools and click WebDownloader. For more information on accessing Fiery WebTools, see [page 7-1](#).**3. Select the print connection and the file you want to download.****Managing printer fonts**

The Fiery includes 136 PostScript fonts; for a complete list, see [Appendix B](#). In addition, two Adobe Multiple Master fonts are included and used for font substitution in PDF files.

Before downloading a file that uses fonts not resident on the Fiery, you must download the fonts (unless the fonts are embedded in the file). To see which fonts are resident on the Fiery, choose Font List from the File menu or click the Font List button (see [page 4-11](#)).

You can download fonts only via the Direct connection. If you do not have access to the Direct connection, you must embed any special fonts used by the file when you generate it.

The screen fonts that correspond to the printer fonts installed on the Fiery are not automatically installed on your Windows system.

NOTE: Fiery Downloader cannot download TrueType fonts. If you use TrueType fonts in Windows, convert them to Adobe Type 1 before printing. To convert to Adobe Type 1 fonts for Windows 9x/Me, click the Fonts tab in the Adobe PS printer driver and set up the Font Substitution Table. For Windows NT 4.0/2000/XP, click the PostScript tab of the Fiery Document Defaults dialog box and select TrueType Font Setting > Download as Softfont.

Printer fonts and Mac OS screen fonts

Like all PostScript fonts, the fonts included with the Fiery come in two forms: printer fonts and screen fonts. Install the screen fonts included with the Fiery user software on your Mac OS computer. If you are using these fonts in documents you print to a LaserWriter, they are probably already installed. If not, you must install them. For more information, see the *User Software Installation Guide*.

Occasionally, you may want to use Adobe Type 1 (Windows) or PostScript (Mac OS) fonts that are not included with the Fiery. If so, you must install both the screen fonts and the printer fonts on your computer. To do this, follow the instructions from the font manufacturer.

Downloading printer fonts to the Fiery

In general, each time you print from within a Mac OS application, the application automatically downloads any fonts used in your document that are not installed on the Fiery, as long as the printer fonts are installed in your System Folder. These fonts remain in the Fiery only until your document has printed. If you print the same document again, your application must download the fonts again.

If you regularly use one or more fonts from Windows or Mac OS applications that are not already installed in the Fiery, you can save time by downloading them to the Fiery hard disk with Fiery Downloader. Fonts you download to the Fiery hard disk remain installed until you remove them using Fiery Downloader, no matter how many times the Fiery is turned off and on. Consider downloading fonts you use on a regular basis to the Fiery hard disk.

Before you download PostScript, TIFF, or EPS files with Fiery Downloader, make sure all fonts included in your file are installed on the Fiery or embedded in your file; otherwise, the text in these fonts will not print correctly or may not print at all. For PDF files, font substitution occurs automatically for fonts not installed on the Fiery. Two multiple master fonts (a serif font and a sans serif font) stored on the Fiery are used exclusively for substitution with PDF files.

TO VIEW FONT INFORMATION, UPDATE, PRINT, AND DELETE FONTS

- **Choose Font List from the File menu or click the Font List button.**

The Font List dialog box includes Update, Print, and Delete buttons. The printer fonts included with the Fiery (resident fonts) are locked. Locked fonts appear with a Lock icon next to the name and cannot be deleted.

Click to print the Font List to the Print queue

Select a font and click here to delete it

Click to update the information
in the Font List

Lock icon

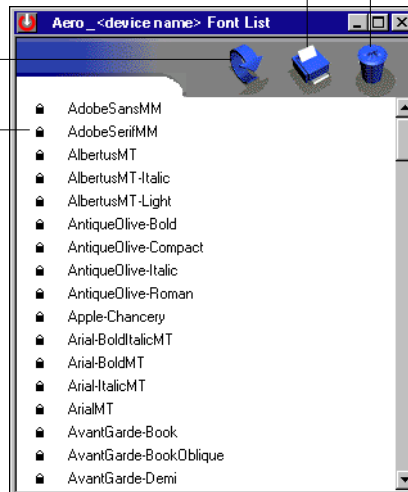

Chapter 5: Printing Variable Data Documents

This chapter describes the variable data printing features supported by the Fiery, including:

- Background information about variable data printing
- Printing variable data documents using Fiery FreeForm™

About variable data printing

Variable data printing is typically used for direct-mail advertising or other targeted mailings. It involves combining a set of master elements that are common across copies of a document with a set of variable elements that change from copy to copy. An example is a brochure that greets customers by name and may include other personal information about the customer obtained from a marketing database. Background elements, illustrations, and text blocks that do not change across copies of the brochure comprise the master elements. The customer's name and other customer-specific information comprise the variable elements.

The Fiery FreeForm feature allows you to use print options to define and store master-element documents—called FreeForm masters—on the Fiery. You can send a variable-element job to the Fiery with instructions to combine the job with a particular Fiery FreeForm master.

When printing variable data, you cannot use Combine Separations. For more information, see [Appendix A](#).

Printing variable data documents with Fiery FreeForm

In Fiery FreeForm variable data printing, you can use print options to define master documents and assign them to variable data jobs sent to the Fiery.

How Fiery FreeForm works

The basic premise of Fiery FreeForm variable data printing is that the master-element data for the job can be sent to the Fiery and rasterized separately from the variable-element data. The master-element data is stored on the Fiery in rasterized form as a FreeForm master, and can be used as often as needed with multiple sets of variable-element data. Because the FreeForm master job is preRIPped and stored on the Fiery, the only RIP time required for variable data print jobs is the time needed to RIP the variable-element data. You can use FreeForm masters for any fixed-element data you might combine with different data from day to day. For example, a letterhead template can be stored as a FreeForm master and used repeatedly as the background for different letter content (the variable-element data).

Fiery FreeForm allows you to create the master and variable documents using any application. You can create the two documents using different applications or computer platforms. To create the masters document, you can use a page layout or graphics application. To create the variable document, you can use a word processing application that has a mail merge feature, a page layout application that supports scripting, or a database application.

FreeForm functions are controlled with two print options: Create Master and Use Master. You can set these options in the printer driver when you send a job, or instruct the operator to set them with job overrides from Command WorkStation, Fiery Spooler, or Fiery WebSpooler. You can also use Command WorkStation to monitor and manage all the FreeForm masters stored on the Fiery. For more information, see the *Job Management Guide*.

Creating the master document

Before you can use Fiery FreeForm, you must create a master document and a variable document. This includes creating the layout for the combined document, as well as the elements themselves. In a page layout or graphics program, you arrange the master elements (text and graphics that do not change) on one or more pages, leaving space for the variable elements.

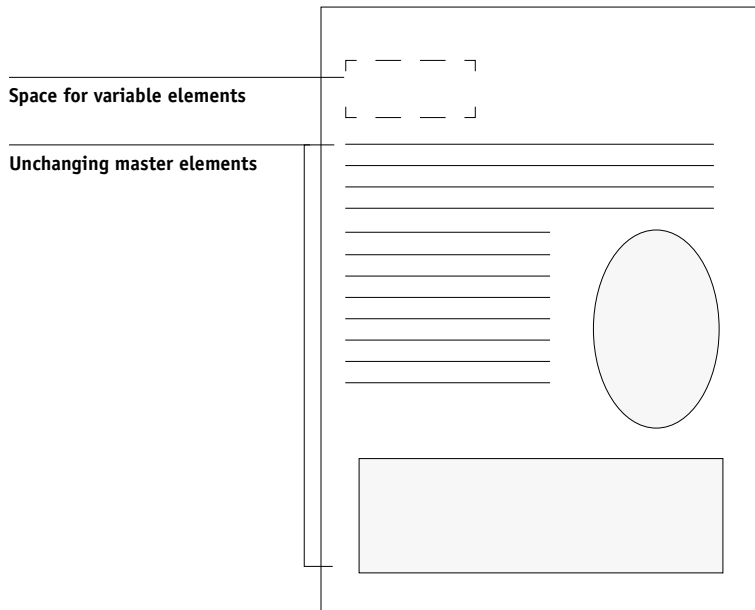

Master document

When you have finalized the design of the master document, print it to the Fiery and specify that a FreeForm master be created from the job (see [page 5-8](#)).

NOTE: Although the Fiery can store up to 100 FreeForm masters, the printer driver interface, Fiery WebSpooler, and Fiery Spooler allow you to select numbers 1 through 15 only. To create a FreeForm master with a number greater than 15, the operator must set the Create Master and Use Master options and RIP the job from Command WorkStation.

Creating the variable document

You can create the variable document with a word processing application that provides a mail merge function, a database application, or a page layout application that supports scripting. In all cases, information is taken from a list or database and merged into an existing document that is set up to accept the information. Each application has different controls for this function; for detailed instructions, see the application documentation.

Before the variable elements can be added to the master document, they must be formatted to conform to the layout of the master document. To do this, you create a document with the correct formatting, and then add the variable information in the appropriate places.

For efficient variable data printing, create a variable document that has significantly more pages than its corresponding FreeForm master.

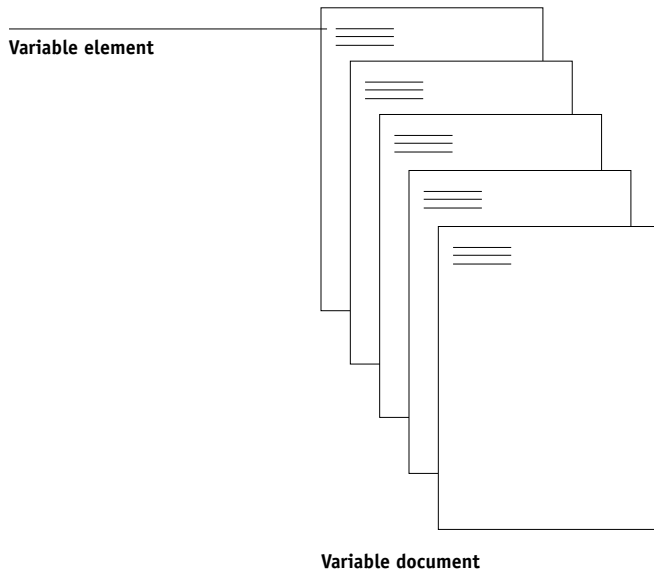

When you have created a variable document, print it to the Fiery and specify that it be combined with the corresponding FreeForm master (see [page 5-8](#)).

Combining the FreeForm master with the variable document

When you print a variable document to the Fiery, you specify the FreeForm master created from your master document with the Use Master print option. The Fiery combines the raster data of the variable document with the already RIPped FreeForm master, creating a new raster data file. The merged raster file can be soft-proofed (before it is printed) in the thumbnail windows of Command WorkStation, Fiery Spooler, or Fiery WebSpooler.

For more information about soft-proofing and thumbnail windows of Command WorkStation, see the *Job Management Guide*.

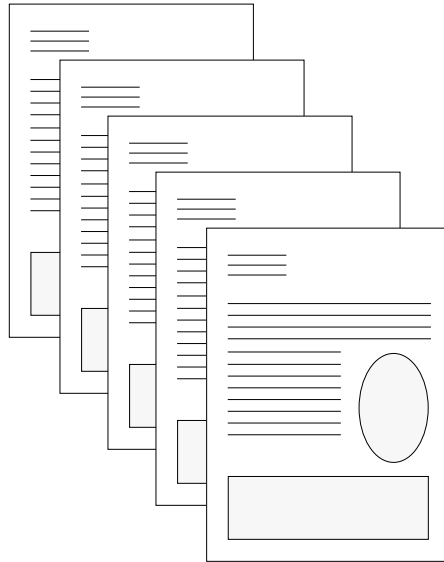

Combined document

A master document can include more than one page. When you print a variable document and specify a FreeForm master that contains multiple pages, the variable pages are combined with the master pages in a cyclical fashion. The following example illustrates how a variable document combines with a two-page master document.

5

5-6 Printing Variable Data Documents

Pages 1 and 2 of the variable document are combined with Pages 1 and 2, respectively, of the master document. The cycle of master pages then starts over, and Pages 3 and 4 of the variable document are combined respectively with Pages 1 and 2, again, of the master document. This pattern continues for each subsequent set of pages in the variable document.

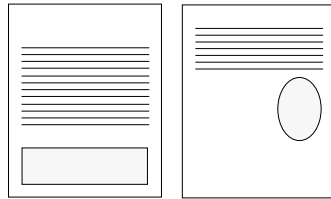

Multiple-page master document

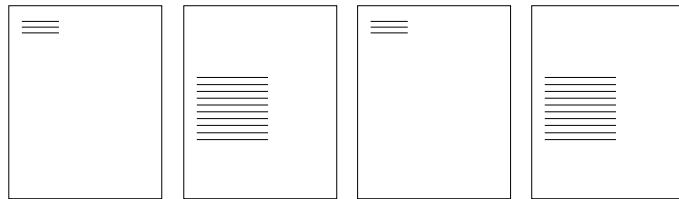

Variable document

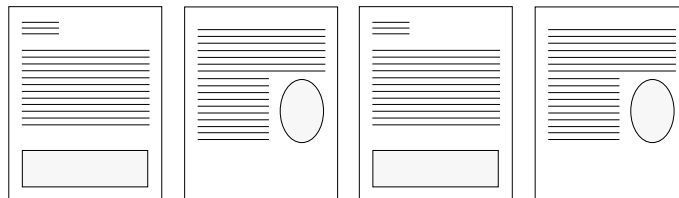

Combined document

Using Fiery FreeForm

This section provides some suggestions to help you print variable data jobs correctly.

- Consult your administrator or operator on how FreeForm master numbers are assigned at your site.

If FreeForm printing is used by a large number of users at your site, FreeForm master numbers, or ranges of numbers, can be assigned to specific users or groups. Users can select only numbers 1 through 15 as print option settings. The operator can override FreeForm master numbers and reassign them to numbers greater than 15 from Command WorkStation. You may want the operator to assign all FreeForm master numbers to avoid potential conflicts in the use of FreeForm master numbers.

- Use the Job Notes and Instructions fields to communicate instructions about your job to the operator.

If you want to create or use a FreeForm master number greater than 15, these fields can be used to tell the operator to override the appropriate job setting (Create Master or Use Master) and RIP the job from Command WorkStation.

- Give your jobs unique and descriptive names.

Both you and the operator must be able to easily identify your jobs if there are many jobs in the queues, the FreeForm master numbers are reassigned, or you want to refer to another job in the Job Notes or Instructions fields.

- For restrictions on print option settings when using Fiery FreeForm, see [Appendix A](#).

The following settings for the master document and variable document must match:

Color Mode

Page Size

The following settings for the variable document might override the corresponding settings in the master document:

Duplex

Media Type

Paper Source

Black Detection

5

5-8 Printing Variable Data Documents

Copier Mode

Page Order

Stapler Mode

Slip Sheet

NOTE: The Top-Top print option of the Duplex setting has no effect when printing using Fiery FreeForm.

TO PRINT VARIABLE DATA DOCUMENTS

1. Create a master document.

The following example shows one page of a master document for a tri-fold brochure that was created with a page layout application.

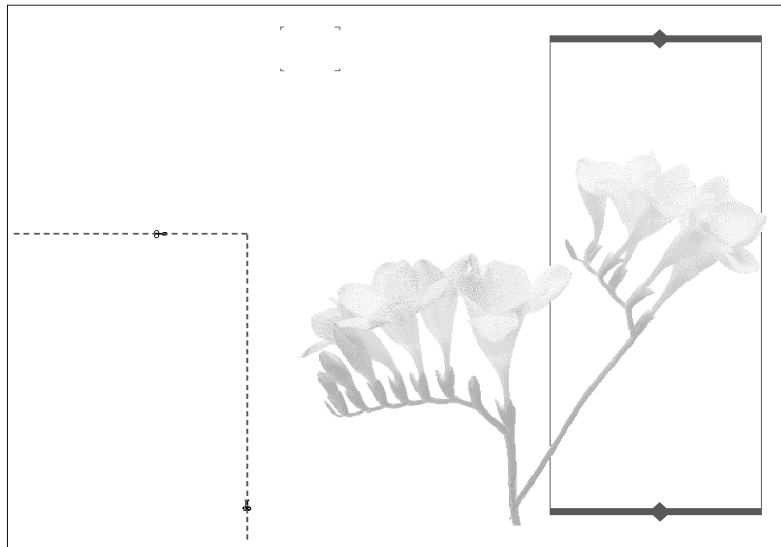

2. Print the master document to the Fiery with the Create Master print option set to one of the FreeForm Master numbers (1 through 15).

Or, set the Create Master option to None and instruct the operator to use overrides to create a FreeForm master from this job.

3. Create the variable document.

You can create the variable document using a different file, a different application, or a different computer platform than was used to create the master document, but some print options must be the same (for details see [page 5-7](#)).

The following example shows one page of the variable document for the tri-fold brochure. The data in this document can be as simple as a name and address, or as complex as multiple, full-color graphics and photographic elements.

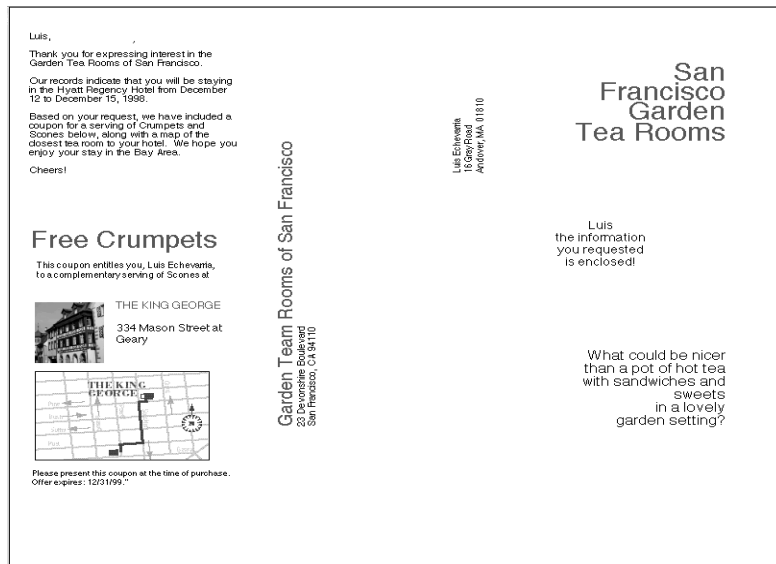

4. Print the variable document to the Fiery with the Use Master print option set to the appropriate FreeForm master number.

The FreeForm master number may be one you set when you sent the master document, or one that was assigned by the operator.

If you want to check the job before it prints, instruct the operator to RIP and Hold the job so you can preview it from Command WorkStation, Fiery Spooler, or Fiery WebSpooler.

The following example shows the FreeForm master and variable document combined. The variable data is simply overlaid on the master document.

Danielle,

Thank you for expressing interest in the Garden Tea Rooms of San Francisco.

Our records indicate that you will be staying in the Saint Francis Hotel from September 12 to September 18, 2002.

Based on your request, we have included a coupon for a serving of Crumpets and Scones below, along with a map of the closest tea room to your hotel. We hope you enjoy your stay in the Bay Area.

Cheers!

San Francisco Garden Tea Rooms

Danielle
the information
you requested
is enclosed!

What could be nicer
than a pot of hot tea
with sandwiches and
sweets
in a lovely
garden setting?

Free Crumpets

This coupon entitles you, Danielle Abrams, to a complimentary serving of Scones at



THE PARK HYATT
333 Battery at Jones
Street



Please present this coupon at the time of purchase.
Offer expires: 12/31/02

Garden Tea Rooms of San Francisco

23 De Vinnaire Boulevard
San Francisco, CA 94110

Danielle Abrams
10510 Folsom Place
San Francisco, CA 94110

Chapter 6: Scanning

With the Fiery Remote Scan TWAIN plug-in module, you can retrieve and display a scan from the Fiery in a host application, such as Photoshop. With the Fiery Remote Scan application, you can retrieve and send the scan to a specific destination. You can also use the WebScan WebTool to retrieve a scan.

The following requirements and constraints apply:

- Fiery Remote Scan cannot be used over the parallel port; it requires a network connection. For information on supported networking protocols, see the *User Software Installation Guide*.
- Fiery Remote Scan must be installed as described in the *User Software Installation Guide*.
- Photoshop RGB Setup should use EFIRGB ICC (Mac OS) or EFIRGB.icm (Windows) settings. For information on loading this file, see the *User Software Installation Guide*.

Fiery Remote Scan components

Fiery Remote Scan consists of the following software components and features:

- The Fiery Remote Scan TWAIN plug-in module and the Fiery Remote Scan application allow you to remotely retrieve a scan from a remote computer on the network to a copier.
- Scan to E-mail
- Scan to Disk
- Scan to Hold queue for document merging and editing
- Scan to FTP
- WebScan for mailbox retrieval using Fiery WebTools

Using Fiery Remote Scan

With the Fiery Remote Scan module, you can retrieve scan files remotely. You can upload a scanned job directly into Photoshop and send the scanned job to a particular destination from the copier. You can then retrieve files using Fiery Remote Scan, WebScan, or Command Workstation. For information on the WebScan WebTool, see “[To retrieve scan files using WebScan](#)” on page 6-8.

Retrieving scans using Fiery Remote Scan

When you retrieve a scan, you first scan the image to a mailbox. You then upload the scanned document to Photoshop, or save it to the Hold queue or disk, or send it via e-mail, or send it to an FTP site.

When you send a scan file to the Hold queue, the Fiery automatically stores the file on the Fiery hard disk. You can then manipulate the file using DocBuilder Pro and Command WorkStation. For information about using DocBuilder Pro, see the *Job Management Guide*. You can also save the scan to your local desktop computer.

When you send a scan file via e-mail, you can send the scan file as either an attachment or a URL. If you send an attachment that exceeds the maximum scan file size specified, the scan file is automatically sent as a URL.

NOTE: Fiery Remote Scan for Windows and Mac OS versions are similar. The following procedures use Windows illustrations, with any Mac OS differences noted.

NOTE: Depending on the PhotoShop version, the Fiery Remote Scan TWAIN Plug-in module dialog boxes may vary.

TO RETRIEVE SCANNED JOBS INTO PHOTOSHOP WITH THE FIERY REMOTE SCAN APPLICATION OR THE FIERY TWAIN PLUG-IN MODULE

1. **If you are using the Fiery Remote Scan application, start the Fiery Remote Scan application.**
2. **If you are using the Fiery Remote Scan TWAIN plug in, start Photoshop, choose Import from the File menu, and click Fiery Remote Scan.**
3. **Select the Fiery in the Choose Device dialog box and click OK.**
4. **Click the Retrieve tab.**

6

6-3 Using Fiery Remote Scan

Fiery Remote Scan application

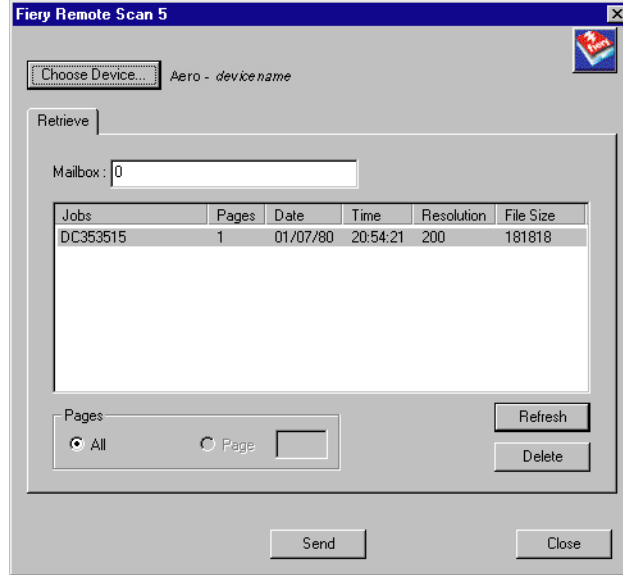

Fiery Remote Scan TWAIN plug-in

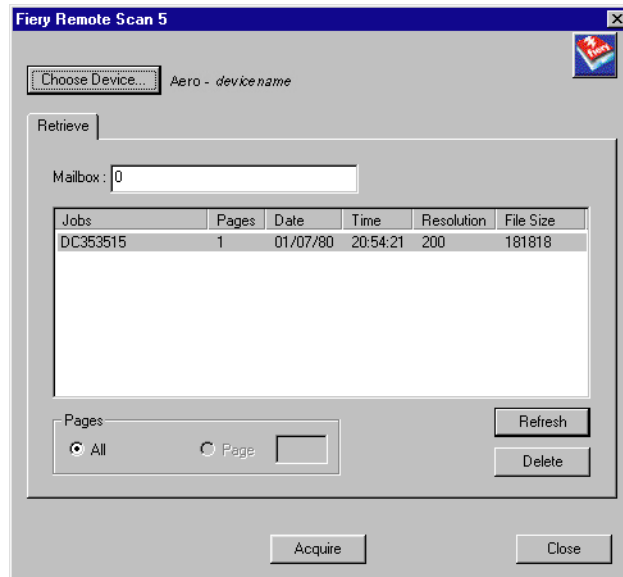

5. Enter the Mailbox name.

NOTE: Mailbox names are case sensitive.

6. Click Refresh.

All scanned images for that mailbox are listed.

7. Select the job and select a Page setting.

To open all pages of a scan, select All; to open a specific page, select Page and enter the specific number in the Page field.

8. Click Send (Fiery Remote Scan application) or Acquire (Fiery Remote Scan TWAIN Plug-in).

If you click Acquire, the scan file automatically opens in the host application, where you can view and edit the file. If you click Send, you are prompted to send the scan file to a specific destination. For more information, see [“Sending the scan job to a specific destination”](#) on page 6-4.

To delete a scanned job from the Fiery, select the job and click Delete.

Sending the scan job to a specific destination

When you retrieve a scan, you can select where to send the scan file. You can send the scan to the Hold queue, disk, e-mail, or FTP.

TO SEND A SCAN JOB TO A DESTINATION

1. After selecting the scan file to send, click Send at the bottom of the Send dialog box.

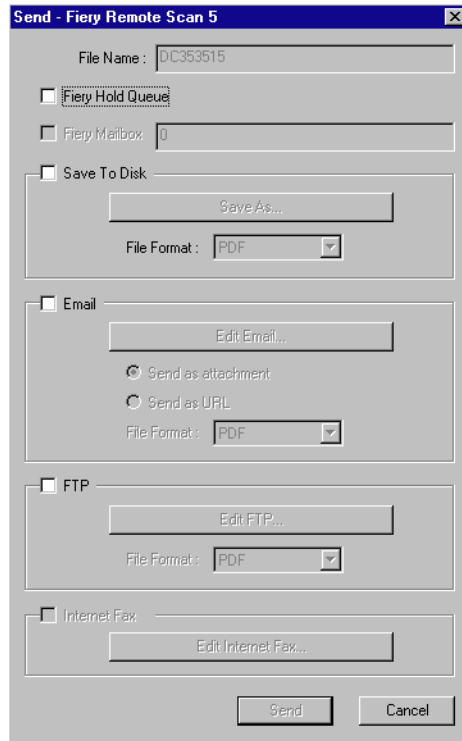

2. To send the job to the Hold queue, select Fiery Hold Queue.
3. To send the scan job to a disk drive, select Save to Disk, choose a file format, and click Save As.

Select the drive location and a file name, and then click Save.

4. To send the scan job via Email, select Email and click Edit Email.

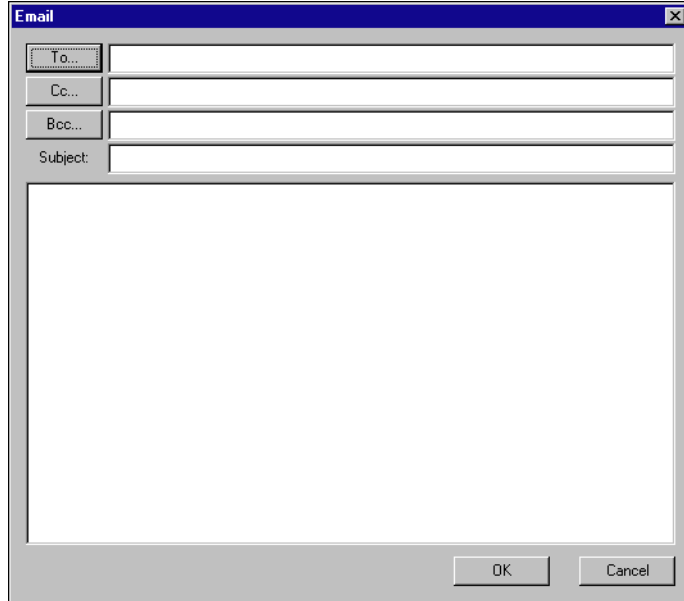

The Email message dialog box appears.

5. Enter an Email address in the To: field, or browse the list of Email addresses in the Address Book by clicking To:, Cc:, or Bcc:.

You can enter a Subject line and body text.

6. Click OK.

Indicate whether you want to send the file as an e-mail attachment or a URL, and choose a File Format (TIFF or PDF).

NOTE: Scanned TIFF files are in TIFF 6 format.

NOTE: If you open a TIFF 6.0 format file, use an application that supports this format. Scan jobs with multiple pages are not supported on some applications using TIFF 6. For more information, see your application documentation.

7. To send the scan job to an FTP site, select FTP and click Edit FTP.

The screenshot shows a dialog box titled "FTP Destination - Fiery Remote Scan 5". It contains the following fields and controls:

- Server Name: [Text Field]
- Path: [Text Field]
- Port Number: [Text Field] with value 21
- Timeout: [Text Field] with value 30, followed by "Seconds"
- Anonymous Login
- User Name: [Text Field]
- Password: [Text Field]
- Proxy Enable
- Proxy Address: [Text Field]
- Proxy Port Number: [Text Field]
- Proxy User Name: [Text Field]
- Proxy Password: [Text Field]
- Buttons: Validate, OK, Cancel

The FTP Destination dialog box appears.

8. Enter the FTP settings and click OK.

If a proxy server has been enabled, click Proxy Enable and enter the information for the proxy server.

9. Indicate whether you want to send the file as an attachment or a URL, and choose a File Format (TIFF or PDF).

NOTE: Scanned TIFF files are in TIFF 6 format. If you open a TIFF 6.0 format file, use an application that supports this format. Scan jobs with multiple pages are not supported on some applications using TIFF 6. For more information, see the documentation for your application.

10. Click Send.

Your job is sent to the selected destination.

Using WebScan

You can also download scanned files from the server using WebScan from Fiery WebTools. You can create and delete mailboxes with WebScan.

Retrieving Scans with WebScan

When you use WebScan to retrieve files, you can save the file to disk, or you can open the file directly from the server.

TO RETRIEVE SCAN FILES USING WEBSCAN

1. Click the WebScan WebTool in the Fiery WebTools menu on the home page.

The WebScan dialog box appears.

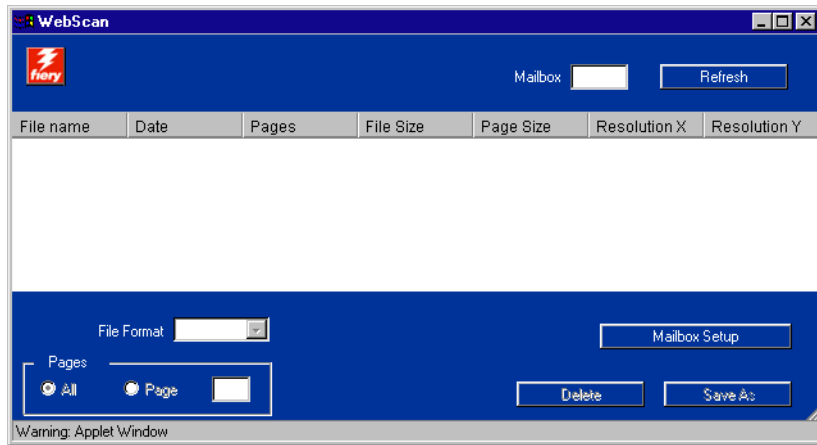

2. Enter the Mailbox name and click Refresh.

All scanned documents in the Mailbox are displayed.

NOTE: Mailbox names are case sensitive.

WebScan lists the following information about each scanned job: File name, Date, Pages, File Size, Page Size, Resolution X, and Resolution Y.

6

6-9 Using WebScan

3. Select the file you want to open.

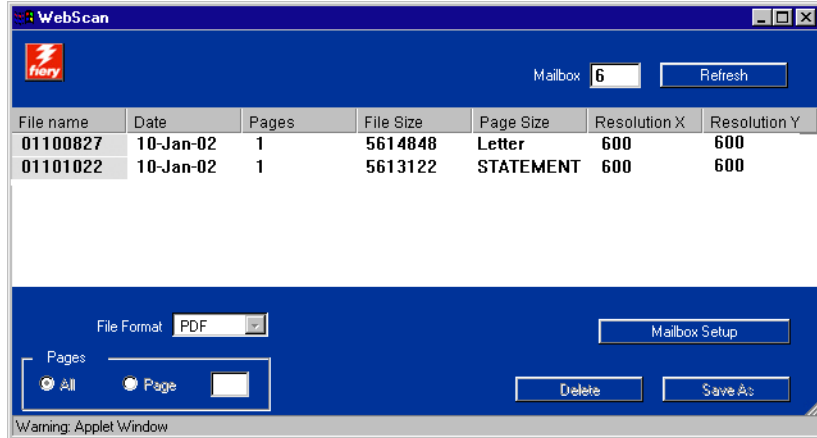

4. Choose PDF, TIFF, or JPEG from the File Format menu.

You can specify the pages you want to retrieve from your job if you choose JPEG from the File Format menu.

If you want to open all pages of scan click All. If you want to open the specific page, specify the Page number to scan.

NOTE: Scanned TIFF files are in TIFF 6 format. If you open a TIFF 6.0 format file, use an application that supports this format. Scan jobs with multiple pages are not supported on some applications using TIFF 6. For more information, see the documentation for your application.

5. Click Save As.

NOTE: Depending on the browser you are using, you may be asked to indicate whether you want to open the file from its current location, or save the file to disk.

The scanned image is displayed in your web browser.

NOTE: You must have Adobe Acrobat installed to view a scanned PDF.

6. To print the job, choose Print from the File menu.

To delete a scanned image from the Fiery hard disk, select the file that you want to delete from the WebScan window and click Delete.

TO SET UP A MAILBOX USING WEBSCAN

1. From Webscan, click Mailbox Setup.

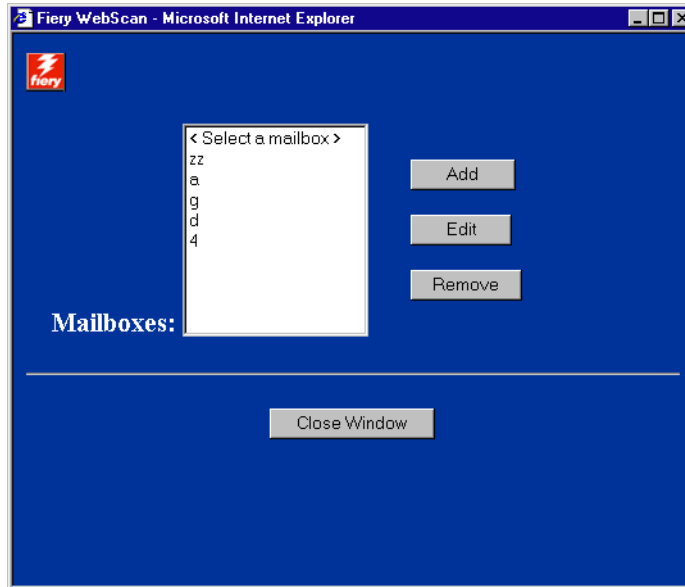

2. Click Add.
3. Enter a mailbox name and color mode.
NOTE: You can enter up to 20 characters or digits.
4. Click Create.

TO DELETE A MAILBOX FROM WEBSCAN

1. From WebScan, click Mailbox Setup.
2. Click on the mailbox name.
3. Click Remove.

Chapter 7: Tracking and Monitoring Jobs

Fiery user software includes a variety of tools that allow you to track and manage print jobs. Access to some tools is controlled by your site administrator, but other tools are available to all users.

- Command WorkStation, Fiery WebSpooler, and Fiery Spooler all provide the capability to view and control the flow of print jobs to the Fiery. If the administrator has set Administrator and Operator passwords in Setup, you must have one of these passwords to perform most Command WorkStation, Fiery WebSpooler, and Fiery Spooler functions. For information on these tools and the access privileges needed to use them, see the *Job Management Guide*.
- Fiery WebTools do not require any special access privileges. As long as the administrator has enabled Web Services in Setup and provided users with the IP address of the Fiery, anyone can use them.

Accessing Fiery WebTools

Fiery WebTools reside on the Fiery's hard disk, but can be accessed over the network from a variety of platforms. The Fiery home page allows you to view server functions and manipulate jobs remotely. This chapter describes only the Status, WebLink, and PrintMe WebTools.

For information on Fiery WebSpooler, see the *Job Management Guide*. For information on the Installer, see the *User Software Installation Guide*. For information on WebSetup, see the *Configuration Guide*. For information about WebScan, see [Chapter 6](#). For information about WebDownloader, see [Chapter 4](#).

TO ACCESS FIERY WEBTOOLS

- 1. Start your Internet browser.**

For information about supported platforms and browsers, see the *User Software Installation Guide*.

- 2. Type the IP address or the DNS name of the Fiery.**

For this information, contact the operator or administrator.

- 3. If a Log In dialog box appears, select Guest and click OK.**

The Log In dialog box appears only if the administrator has set a password. Guest access is sufficient to use the Status and WebLink WebTools, as described in this chapter.

- 4. When the Fiery home page appears, click to select one of the Fiery WebTools.**

Move the cursor over the buttons to display information about the selections.

Checking Fiery status with the Status WebTool

You can use Status to see what jobs are currently processing and printing. To access Status, open the Fiery home page and click Status. The current RIP Status and Printer Status appear in the window.

NOTE: For best results, use WebTools at the recommended resolution. For more information, see System Requirements in the *Quick Start Guide*.



To open a new browser window for the Status display, click Float. You can then close other browser windows and leave the Status window open to continue checking the status of the Fiery. As long as you keep the Status window open, it is dynamically updated.

To obtain more information about the status of jobs, use WebSpooler, Fiery Spooler, or Command WorkStation, as described in the *Job Management Guide*.

Accessing information with WebLink

WebLink on the Fiery home page provides a link to another web page or to multiple web pages, provided you have a valid Internet connection. The administrator at your site can set the WebLink destination. Check your Fiery WebLink for any available information

Accessing PrintMe with the PrintMe WebTool

PrintMe on the Fiery home page provides a link to the PrintMe web page.

The administrator at your site can enable PrintMe on the Fiery. For more information on configuring PrintMe on the Fiery, see the *Configuration Guide*.

TO ACCESS PRINTME FROM WEBTOOLS

- 1. Start your Internet browser.**

For information about supported platforms and browsers, see the *User Software Installation Guide*.

- 2. Type the IP address or the DNS name of the Fiery.**

For this information, contact the operator or administrator.

- 3. If a Log In dialog box appears, select Guest and click OK.**

The Log In dialog box appears only if the administrator has set a password. Guest access is sufficient to use the Status and WebLink WebTools, as described in this chapter.

4. When the Fiery home page appears, click the PrintMe WebTool.

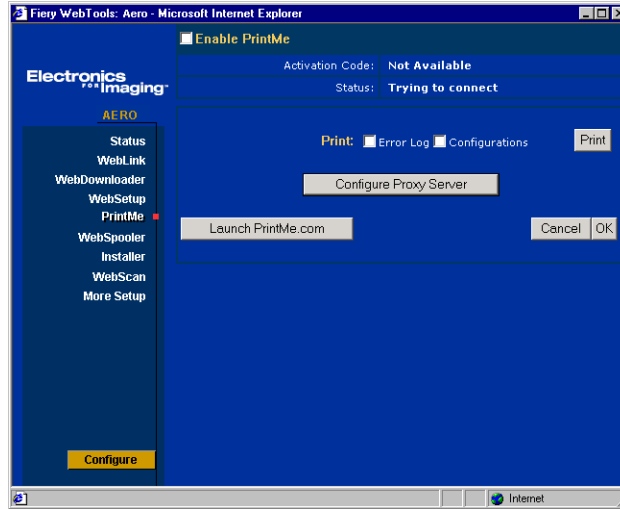

5. Click Launch PrintMe.com.

The PrintMe.com web site appears. For more information on using PrintMe, refer to the documentation on the PrintMe web site.

Chapter 8: Using Fiery E-mail Service

The Fiery E-mail Service allows you to remotely print to and control the Fiery using your current e-mail infrastructure. It allows you to print to remote locations and bypass firewalls. With Fiery E-mail Service, you can submit jobs to the Fiery as e-mail attachments.

You can use Fiery E-mail Service in the following ways:

- Print using an E-mail Client
- Print using the Fiery E-Mail Port Monitor
- Scan using Scan to E-mail

How Fiery E-mail Service works

In order to use the E-mail services, you must set up Fiery E-mail Service as described in the *Configuration Guide*.

To print with an E-mail Client, you send a file as an e-mail attachment, and Fiery E-mail Service extracts the file and sends it to the Fiery. The e-mail attachment must be a PS or PDF file.

To print using the Fiery E-mail Port Monitor, you must print to a printer connected to the Fiery E-mail Port Monitor. If you have the E-mail Port Monitor set up, your print job is e-mailed to the Fiery when you choose Print from an application. For more information about setting up the E-mail Port Monitor, see the *User Software Installation Guide*.

Fiery E-mail Service also supports Scan to E-mail features that allow you to scan a document and send it to an e-mail address as an attachment or URL. For more information about Scan to E-mail, see [Chapter 6](#).

The Fiery also supports internal address books. Administrators can retrieve, add, delete, and clear addresses from the address books by sending requests via e-mail. For more information about address books, see the *Configuration Guide*.

NOTE: Fiery E-mail Service will not process .vbs, .exe, or .bat extensions.

Printing using an E-mail Client

You can submit print jobs to the Fiery in the form of an e-mail attachment using your e-mail application. When you send an e-mail with an attachment, Fiery E-mail Service extracts the file and sends it to the Fiery Print queue. The file format must be one supported by the Fiery.

By default, anyone can print with an E-mail Client, unless the Print address book has been set up by the Administrator. If your e-mail address is not in the Print address book, you cannot send files to the Fiery via e-mail. For more information about address books, see the *Configuration Guide*.

NOTE: The Direct and Hold queues are not supported by the E-mail Client feature.

NOTE: The illustrations in the following procedure depict Microsoft Outlook E-mail.

TO PRINT USING AN E-MAIL CLIENT

1. **Open your e-mail application.**
2. **Enter the Fiery e-mail address in the To: line.**
3. **Enter text in the Subject line or leave the Subject line blank.**

4. Attach the file you want to print in the body of the e-mail.

You can enter a additional text in the body of the message, if necessary. The text will also be printed.

NOTE: If your attachment exceeds the file size limitation set by your e-mail system administrator, the e-mail will not be sent.

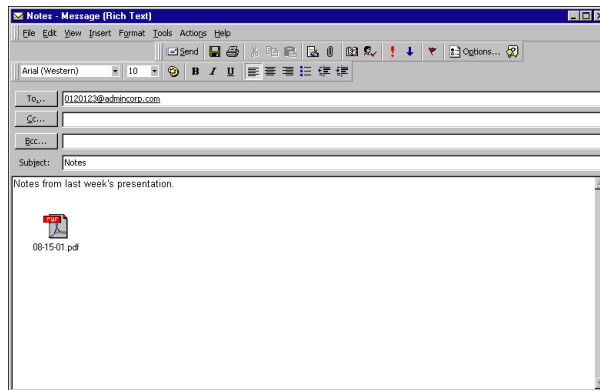

5. Click Send.

The file is sent to the Fiery and the job is printed. After the Fiery receives the job, you will receive an e-mail notification that the print job was accepted if you have the Email client set up to receive e-mail responses. The e-mail notification also provides a job identification (ID), which allows you to manage jobs with Job Control (see the following section). The e-mail notification indicates any current error at the copier.

Once the job has been printed, you receive a second e-mail notification that indicates the job printed successfully.

To check the status of your job, use Job Control to see if the job printed successfully.



Job Control

This feature allows you to manage print jobs by submitting commands to the Fiery via e-mail. You can cancel a job, check job status, and inquire help on a job. Once you send a command, the Fiery returns an e-mail response.

TO MANAGE PRINT JOBS WITH JOB CONTROL

1. **In your e-mail application, enter the Fiery e-mail address in the To: line.**
2. **Enter one of the following Job Control commands in the Subject line.**

To check the status of a job, enter #JobStatus<job id> in the Subject line.

You will receive an e-mail response to your job status query. You can only inquire about the status of the job if you sent the job or are an administrator.

To cancel a job, enter #CancelJob<job id> in the Subject line.

You will receive an e-mail response indicating that the job has been cancelled and will not print to the Fiery. You can only cancel the job if you sent the job or are an administrator.

To inquire help, enter #Help in the Subject line.

You will be sent an e-mail response that contains the links that allow you to cancel jobs, check job status, and search and manage address books. Click any of the links to perform a Job Control command.

Printing using the E-mail Port Monitor

Once you set up the E-mail Port Monitor, you can print using Fiery E-mail Service in the same manner as any other printing method. No additional steps are necessary.

NOTE: The E-mail Port Monitor is only supported on Windows.

NOTE: The Direct connection is not supported when printing with E-mail Port Monitor.

TO PRINT USING THE FIERY E-MAIL PORT MONITOR

1. Choose Print in your application.
2. Make sure the Fiery is selected as your printer and you have set up the E-mail Port Monitor for the Fiery.
3. Click Properties.
4. Click the Fiery Printing tab.

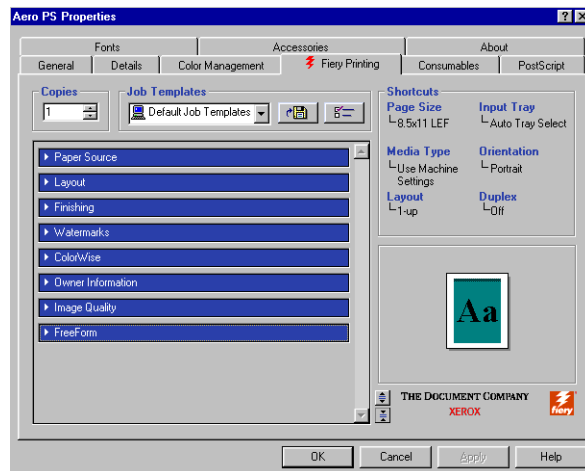

NOTE: Supported tabs and print options may vary between Windows 9x/Me, Windows NT 4.0, and Windows 2000/XP PostScript drivers. For a complete list of print options, see [Appendix A](#).

5. Set the print options and click OK.

Your job is sent to the Fiery.

To set options using the printer driver, see “Setting options and printing from Windows computers” on page 1-2.

NOTE: If the attachment exceeds the file size limitation set in your application, the attachment may be broken into several smaller messages.

Appendix A: Print Options

Print options give you access to the special features of your copier and Fiery. Print options can be specified in several places—in Fiery Setup, or from the printing application, Fiery Downloader, ColorWise Pro Tools, Command WorkStation, Fiery WebSpooler, or Fiery Spooler. The table in this appendix briefly describes each print option and its default setting, and provides information on any constraints or requirements in effect.

About printer drivers and printer description files

The Fiery receives files from computers on the network, processes (RIPs) them, and then sends them to the copier. Windows and Mac OS computers communicate with the Fiery by means of a printer driver and printer description (PPD) files. The driver allows you to use special features of the Fiery from the Print dialog box.

A printer driver manages printing communication between your application and the printer. It interprets the instructions generated by the application, merges those instructions with printer-specific options you specify, and translates all information into PostScript, a language the printer understands. The printer driver writes a PostScript file based on your original file and the options you set from the Print dialog box.

A printer driver also allows you to select print options for your copier. To do this, the printer driver must be matched with a PPD file for your Fiery. A PPD file contains information about the features and capabilities of a particular device (for example, what paper sizes and media types are supported). The printer driver reads the information in this file and presents that information to you in the form of options you can choose from the Print dialog box. For information on the specific print options for the Fiery, see the table on [page A-2](#).

Where to set print options

- During Setup

Some settings are specified during Setup by the administrator. For information on the current default server settings, contact the administrator or the operator.

- From applications

With the Adobe PostScript printer drivers, you can specify job settings when you print a job. For information about specifying job settings from applications, see [Chapters 1 and 2](#).

- From Fiery Downloader

Only a few settings—Copies, Page Range (for PDF files only), and Brightness (for PostScript and EPS files only)—can be specified when printing jobs with Fiery Downloader. To change options in Fiery Downloader, select a job in the Files to be Downloaded (Windows) or Files to Download (Mac OS) list and click Options. For more information, see [Chapter 4](#).

- From ColorWise Pro Tools

You can set the default CMYK Simulation Profile, CMYK Simulation Method, RGB Source Profile, RGB Separation, Output Profile, Rendering Style, Spot Color Matching, Pure Black Text/Graphics, and Black Overprint settings. For more information on using ColorWise Pro Tools, see the [Color Guide](#).

- Overrides from Command WorkStation, Fiery WebSpooler, and Fiery Spooler

To change job settings from Command WorkStation, double-click a job to display the Properties dialog box. To change job settings from Fiery WebSpooler and Fiery Spooler, double-click a job to display the Override Print Settings dialog box. For more information, see the [Job Management Guide](#).

Print option override hierarchy

The override hierarchy is as follows:

- A user's printer driver settings override the Fiery Setup and ColorWise Pro Tools settings.
- Settings made from Command WorkStation, Fiery WebSpooler, or Fiery Spooler override the user's printer driver settings.

Default settings

In the following table, underlined settings in the Option and settings column indicate default printer driver settings (PPD defaults). If you do not use the printer driver interface to configure a particular option, the Fiery prints the job with the underlined setting.

For options that can be configured in Setup from the Control Panel, Command WorkStation, WebSetup, or ColorWise Pro Tools, choosing Printer's default results in the Fiery printing the job with the Setup setting specified. For options that cannot be configured in Setup, the Fiery prints the job with a pre-configured Printer's default setting. For more information, see the Requirements, constraints, and information column.

To determine the current Setup defaults, print the Configuration page from Command WorkStation or the Fiery Control Panel.



Option and settings (default setting is underlined)	Description	Requirements, constraints, and information
Black Detection <u>On/Off</u>	Select Off if your job consists of black-only text pages combined with a significant number of color pages. Select On if you are printing a predominantly black and white job.	Color Mode must be set to CMYK, Standard Color, or Expert Color.
Black Overprint <u>Printer's default/Off/On</u>	Select Off to print black text with knockouts. Select On to overprint black text.	The Printer's default setting reflects the setting specified in Fiery Setup. For Windows, choose Expert Color as the Color Mode to access this option. If this option is set to On, the Combine Separations option must be set to Off. Setting this option to On automatically sets the Pure Black Text/Graphics option to On. For more information, see the <i>Color Guide</i> .
Brightness <u>85% Lightest/90% Lighter/95% Light/100% Normal/105% Dark/110% Darker/115% Darkest</u>	Select 85% for a substantially lighter image, 115% for a substantially darker image, or use one of the settings in between.	The Printer's default setting produces the same result as the 100% setting.
CMYK Simulation Method <u>Printer's default/Quick/Full (Source GCR)/ Full (Output GCR)</u>	Select Quick to use one-dimensional transfer curves to adjust density output of individual color channels. Select Full (Source GCR) for a more complete and accurate simulation by applying colorimetric transformations that adjust hue as well as output density. This option produces output that maintains the same amount of black as the source document. Select Full (Output GCR) to apply the same simulation method as Full (Source GCR), except that the output produced contains a black amount determined by the output profile.	The Printer's default setting reflects the setting specified in Fiery Setup. For Windows, choose Expert Color as the Color Mode to access this option. For more information, see the <i>Color Guide</i> .

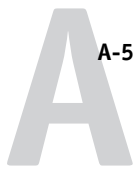

Option and settings (default setting is underlined)	Description	Requirements, constraints, and information
CMYK Simulation Profile <u>Printer's default</u> /SWOP-Coated/ DIC/Euroscale/Simulation-1/ Simulation-2/Simulation-3/ Simulation-4/Simulation-5/ Simulation-6/Simulation-7/ Simulation-8/Simulation-9/ Simulation-10/None/Match Copy	Specify the simulation goal to be used for the current print job.	The Printer's default setting reflects the setting specified in Fiery Setup. For Windows 9x/Me and Windows NT 4.0, choose Expert Color as the Color Mode to access this option. For more information, see the <i>Color Guide</i> .
Collate <u>Off</u> /On	Specify how to output multiple-page/multiple-copy jobs.	For more information, see page A-10.
Color Mode CMYK/Grayscale (from the Mac OS driver) Or Print Mode <u>Standard Color</u> /Expert Color/Grayscale (from the Windows drivers)	Specify the color mode for the current print job. Select CMYK, Standard Color, or Expert Color for a full-color document. Select Grayscale for a grayscale or black-and-white document.	The Printer's default setting reflects the setting specified in Fiery Setup. The options differ depending on which driver you use. For Windows, you must choose Expert Color to set other color print options, including Pure Black Text/Graphics.
Combine Separations <u>Off</u> /On	When printing separations from supported desktop publishing applications: Select On to combine separations on a single page. Select Off to view separations as four individual black-and-white pages, each representing one color plate.	For more information, see the <i>Color Guide</i> .
Copier Mode <u>Photo</u> /Map	Specific Copier Modes produce optimum results with certain files. Choose Copier Mode best suited for your job.	
Copies <u>1</u> -999	Specify the number of copies of the job to print.	Do not enter a value greater than 999.
Create Master <u>None</u> /1-10	To create a FreeForm master from this job, specify a number to assign to the FreeForm master file.	For more information, see page 5-2. Command WorkStation allows you to select up to 100 FreeForm Masters.



Option and settings (default setting is underlined)	Description	Requirements, constraints, and information
Duplex <u>Off/Top-Top/Top-Bottom/Manual</u>	Select Off for simplex (single-sided) printing. Select Top-Top for duplex (double-sided) printing with both sides using the same top edge. Select Top-Bottom for duplex printing with the back side upside down. Select Manual for printing using the Bypass tray.	For more information, see page A-11 .
Group Name	If Printing Groups is enabled, the Fiery Administrator has assigned users to print groups, and passwords to each group. Enter the appropriate Group Name for the print job.	This option is not supported with Mac OS X (native).
Group Password	If Printing Groups is enabled, the Fiery Administrator has assigned users to print groups, and passwords to each group. Enter the appropriate Group Password for the print job.	This option is not supported with Mac OS X (native).
Image Smoothing <u>Automatic/Off/On/Below 90 ppi</u> <u>Below 150 ppi/Below 200 ppi/Below 300 ppi</u>	Set this setting to On to minimize grainy output when printing low-resolution images.	
Input Tray <u>Auto Tray Select/Tray 1/Tray 2/Tray 3/Tray 4/Tray 3 (High Capacity)/ Tray 4 (High Capacity)/Tray 5 (Bypass)</u>	Specify the paper tray to use for your print job.	The Auto Tray Select setting automatically selects the tray containing the paper size specified for the job.
Instructions	Enter instructions for the operator about the job.	This option is not supported with Mac OS X (native).



Option and settings (default setting is underlined)	Description	Requirements, constraints, and information
Media Type (Paper Type) <u>Use Machine Settings/</u> Plain/Bond/Heavyweight1A/ Heavyweight 1B Heavyweight 2A/ Coated1/ Coated2/Gloss 1A/ Coated 1 Gloss/Transparency/Labels	Specify the media type to use for the entire job.	
Notes	Enter information about the job.	The Notes field has a 32-character limit. This option is not supported with Mac OS X (native).
(Other) Gamma <u>Printer's default</u> /1.0/1.2/1.4/1.6/ 1.8/2.0/2.2/2.4/2.6/2.8/3.0	Specify a source gamma value for printing RGB images, objects, and text.	Setting this option to Printer's default produces the same result as the 2.2 setting. For more information, see the <i>Color Guide</i> .
(Other) Phosphors <u>Printer's default</u> /Hitachi EBU/ Hitachi-Ikegami/NTSC/ Radius Pivot/SMPTE/Trinitron	Specify a source phosphors value for printing RGB images, objects, and text.	The Printer's default setting produces the same result as the SMPTE setting. For more information, see the <i>Color Guide</i> .
(Other) White Point <u>Printer's default</u> /5000 K (D50)/ 5500 K/6500 K (D65)/7500 K/9300 K	Specify a source white point value for printing RGB images, objects, and text.	The Printer's default setting produces the same result as the 5000K setting. For more information, see the <i>Color Guide</i> .
Output Destination <u>Center Output Tray</u> /Finisher Tray	Specify the output destination tray for your job.	
Output Profile <u>Printer's default</u> /Output-1/Output-2/ Output-3/Output-4/Output-5/ Output-6/Output-7/Output-8/ Output-9/Output-10/Dot Dcx + (US)/Line Dcx + (US)/Dot ColoTech (Europe)/Line ColoTech (Europe)	Specify the output profile to use for the current print job.	The Printer's default setting reflects the setting specified in ColorWise Pro Tools. For Windows, choose Expert Color as the Color Mode to access this option. For more information, see the <i>Color Guide</i> .



Option and settings (default setting is underlined)	Description	Requirements, constraints, and information
Page Order <u>Forward/Reverse</u>	Select Forward to print the pages of your job from first to last. Select Reverse to print the pages of your job from last to first.	
Paper Size (Page Size) <u>8.5 x 11 LEF/8.5 x 11 SEF/A4 LEF/A5 SEF/A3 SEF/B5 SEF/B4 SEF/A5 LEF/A5 SEF/11 x 17 SEF/12 x 18 SEF/8.5 x 13 SEF/8.5 x 14 SEF/5.5 x 8.5 LEF/5.5 x 8.5 SEF/SRA3 SEF/ Custom Page Sizes</u>	Specify the size of the paper on which to print the document	Custom Page Sizes are only for PostScript.
PowerForm Simulation <u>Printer's Default/On/Off</u>	Select On when printing PowerPoint files to the Fiery.	Setting the PowerForm option to On can reduce the processing time for PowerPoint print jobs.
Pure Black Text/Graphics <u>Printer's default/Off/On</u>	Select Off to print black text and graphics as a four-color black using C, M, Y, and K toner, and to use normal PostScript rendering. Select On to print black text and graphics as a one-color black, using 100% black toner only.	The Printer's default setting reflects the setting specified in Fiery Setup. For Windows, choose Expert Color as the Print Mode to access this option. This option is automatically set to On if the Black Overprint option is set to On. For more information, see the <i>Color Guide</i> .
Remove White PPT Background <u>On/Off</u>	Select On when using PowerPoint to create variable data in conjunction with FreeForm.	
Rendering Style <u>Printer's default/Photographic/Presentation/Relative Colorimetric/Absolute Colorimetric</u>	Specify a default color rendering dictionary (CRD) to use when you print RGB images, objects, and text.	The Printer's default setting reflects the setting specified in Fiery Setup. For Windows, choose Expert Color as the Color Mode to access this option. For more information, see the <i>Color Guide</i> .
RGB Separation <u>Printer's default/Output/Simulation</u>	Select Output for RGB jobs you are printing to the final output device. Select Simulation for RGB jobs for which you want to simulate an output device other than the device you are printing to.	The Printer's default setting reflects the setting specified in Fiery Setup. For Windows, choose Expert Color as the Color Mode to access this option.



Option and settings (default setting is underlined)	Description	Requirements, constraints, and information
RGB Source Profile <u>EFIRGB/sRGB (PC)</u> / Apple Standard/Other/Source-1/ Source-2/Source-3/Source-4/Source-5/ Off	Specify a source color space definition for printing RGB images, objects, and text.	The Printer's default setting reflects the setting specified in Fiery Setup. For Windows, choose Expert Color as the Color Mode to access this option. For more information, see the <i>Color Guide</i> .
Screen Switching <u>On/Off</u>	If Off, all objects on page will use a low frequency screen. If you choose On, text will use a high-frequency screen and graphics and image objects will use a low-frequency screen.	
Sharpness Softer/ <u>Normal</u> /Sharper	Change the Sharpness setting to alter the results of a print. Select Softer to decrease the clarity of the printed image. Softer reduces the clarity than Soft. Select Sharper to increase the clarity of the printed image. The comparative degree interprets the level of the clarity. Select Normal to render a slight sharpness.	
Slip Sheet <u>On/Off</u>	Specify whether to insert a slip sheet between copies of multiple-copy jobs.	
Slip Sheet Paper Source <u>Tray 1</u> /Tray 2/Tray 3/Tray 4/Tray 3 (High Capacity)/ Tray 4 (High Capacity)/Tray 5 (Bypass)	Specify the paper tray to use for the slip sheet.	



Option and settings (default setting is underlined)	Description	Requirements, constraints, and information
Spot Color Matching <u>Printer's default</u> /Off/On	Select Off to print specified PANTONE colors in your job using the current CMYK Simulation and CMYK Simulation Method. Select On to activate the PANTONE Lookup Table. The Fiery prints specified PANTONE colors in your job by matching the CMYK print blend to the same color from the PANTONE library.	The Printer's default setting reflects the setting specified in Fiery Setup. For Windows, choose Expert Color as the Color Mode to access this option. For more information, see the <i>Color Guide</i> .
Stapler Mode <u>Off</u> /Corner/Single/Dual	Specify whether or not to staple the job.	
Tray Alignment On/ <u>Off</u>	Specify if you want to enable tray alignment.	If you select On, Input Tray cannot be set to Auto Tray Select. For more information, see the <i>Job Management Guide</i> .
Text/Graphics Enhancement <u>On</u> /Off	Specify if you want to sharpen the edges of text or vector graphics.	
Use Master None/ <u>1-10</u>	For variable data print jobs, specify a FreeForm master number to be used for the job.	For more information, see page 5-2 . Command Workstation allows you to select up to 100 FreeForm Masters.

More about print options

The following sections provide additional information about print options. For more information on the settings, requirements, and constraints in effect for these options, see the preceding table.

Collate

Use this option to specify sorting options.

Off—Copies of a complete job are output, uncollated, into the top tray.

On—Copies of a complete job are collated and output into the top tray.

Duplex

All duplex printing features are available only with plain paper media type.

TO PRINT DUPLEX PAGES

1. Choose Print in your application and locate the Duplex print option.

The location of Fiery print options varies, depending on the printer driver you are using.

2. Choose one of the Duplex settings:

Top-Top—Prints the top of the image on Side 1, on the same edge of the page as the top of the image on Side 2.

Top-Bottom—Prints the top of the image on Side 1, on the opposite edge of the page from the top of the image on Side 2.

Manual—Prints without using the duplex tray by printing even and odd pages separately from the Bypass tray.

The following table shows how the Duplex settings correspond to printed output:

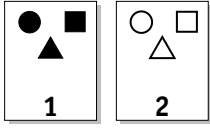
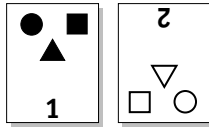
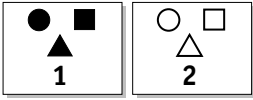
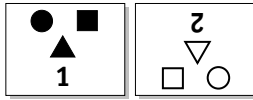
	Top-Top	Top-Bottom
Portrait		
Landscape		

TO PRINT DUPLEX PAGES MANUALLY**1. Choose Print in your application, and locate the Duplex print option.**

The location of Fiery print options varies, depending on the printer driver you are using.

2. Set the Duplex option to Manual.**3. Print the job.**

Make sure there is paper in Tray 5 (Bypass). If you see this message on the copier, “The paper type currently loaded in Tray 5 (Bypass) is different from the driver setting: <mediatype> (S2). Remove Paper from Tray 5 (Bypass) and load <mediatype> (S2)”, ignore the message, remove all sheets in the Tray 5 (Bypass) if there are any, and place the printed pages face down.

4. Remove the pages from the output tray and flip them as shown below.

In either the Top-Top or Top-Bottom row, find the illustration that shows how the pages look in the output tray. Before you place the pages in Tray 5 (Bypass), flip them along the edge indicated by the arrows.

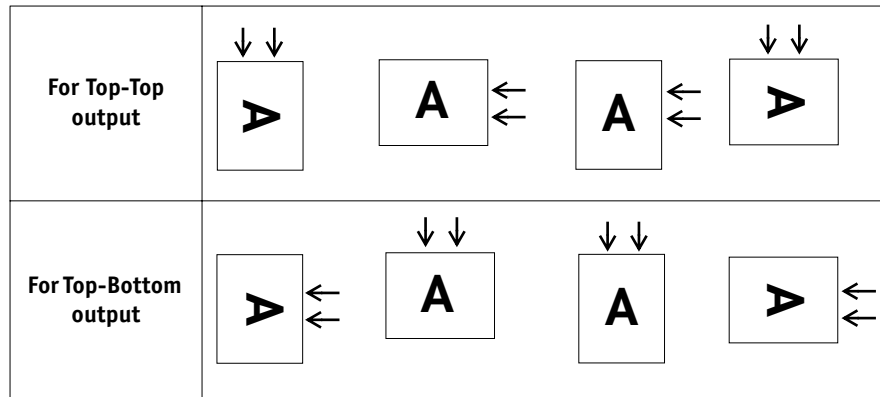

NOTE: For jobs imposed using Fiery Imposition, *always* flip the pages along the long edge of the page.

5. Place the pages in Tray 5 (Bypass), then use the line selection button to choose OK in the Fiery display window.

Appendix B: Font List

This appendix lists the built-in printer fonts included with your Fiery.

PostScript printer fonts

The following table lists the 136 built-in PostScript printer fonts on the Fiery. In addition to these fonts, two Adobe Multiple Master fonts are included and used for font substitution in PDF files.

NOTE: For Mac OS computers, install the corresponding screen fonts from the User Software CD. For instructions, see the *User Software Installation Guide*.

Adobe Type 1 fonts

The Fiery includes 126 Adobe Type 1 fonts:

- The Mac OS column lists the name as it appears on the Font menu on a Mac OS computer. For example, in most applications, to use “Bodoni-Bold,” choose Bodoni Bold from the Font menu.
- The Windows menu name is the name as it appears on the Font menu on a Windows computer. The style refers to the style that must be selected in the application to access the particular PostScript font. For example, to use “Bodoni-Bold,” choose Bodoni from the Font menu and Bold from the Style menu.

PostScript name	Mac OS menu name	Windows menu name, style
AlbertusMT-Light	Albertus MT Lt	Albertus MT Lt
AlbertusMT	Albertus MT	Albertus MT
AlbertusMT-Italic	Albertus MT It	Albertus MT, Italic
AntiqueOlive-Roman	Antique Olive Roman	Antique Olive Roman
AntiqueOlive-Bold	Antique Olive Bold	Antique Olive Roman, Bold
AntiqueOlive-Italic	Antique Olive Italic	Antique Olive Roman, Italic
AntiqueOlive-Compact	Antique Olive Compact	Antique Olive Compact
Arial-BoldItalicMT	Arial Bold Italic	Arial, Bold Italic
Arial-BoldMT	Arial Bold	Arial, Bold
Arial-ItalicMT	Arial Italic	Arial, Italic

PostScript name	Mac OS menu name	Windows menu name, style
ArialMT	Arial	Arial
AvantGarde-Book	Avant Garde	AvantGarde
AvantGarde-Demi	Avant Garde Demi	AvantGarde, Bold
AvantGarde-BookOblique	Avant Garde BookOblique	AvantGarde, Italic
AvantGarde-DemiOblique	Avant Garde DemiOblique	AvantGarde, Bold Italic
Bodoni	Bodoni	Bodoni
Bodoni-Bold	Bodoni Bold	Bodoni, Bold
Bodoni-Italic	Bodoni Italic	Bodoni, Italic
Bodoni-BoldItalic	Bodoni BoldItalic	Bodoni, Bold Italic
Bodoni-Poster	Bodoni Poster	Bodoni Poster
Bodoni-PosterCompressed	Bodoni PosterCompressed	Bodoni PosterCompressed
Bookman-Light	Bookman	Bookman
Bookman-Demi	Bookman Demi	Bookman, Bold
Bookman-LightItalic	Bookman LightItalic	Bookman, Italic
Bookman-DemiItalic	Bookman DemiItalic	Bookman, Bold Italic
Carta	Carta	Carta
Clarendon-Light	Clarendon Light	Clarendon Light
Clarendon	Clarendon	Clarendon
Clarendon-Bold	Clarendon Bold	Clarendon, Bold
CooperBlack	Cooper Black	Cooper Black
CooperBlack-Italic	Cooper Black Italic	Cooper Black, Italic
Copperplate-ThirtyThreeBC	Copperplate33bc	Copperplate33bc
Copperplate-ThirtyTwoBC	Copperplate32bc	Copperplate32bc
Coronet	Coronet	Coronet
Courier	Courier	Courier
Courier-Bold	Courier Bold	Courier, Bold
Courier-Oblique	Courier Oblique	Courier, Italic
Courier-BoldOblique	Courier BoldOblique	Courier, Bold Italic
Eurostile	Eurostile	Eurostile
Eurostile-Bold	Eurostile Bold	Eurostile Bold
Eurostile-ExtendedTwo	Eurostile ExtendedTwo	Eurostile ExtendedTwo

PostScript name	Mac OS menu name	Windows menu name, style
Eurostile-BoldExtendedTwo	Eurostile BoldExtendedTwo	Eurostile ExtendedTwo, Bold
GillSans	GillSans	GillSans
GillSans-Bold	GillSans Bold	GillSans, Bold
GillSans-Italic	GillSans Italic	GillSans, Italic
GillSans-BoldItalic	GillSans BoldItalic	GillSans, Bold Italic
GillSans-Light	GillSans Light	GillSans Light
GillSans-LightItalic	GillSans LightItalic	GillSans Light, Italic
GillSans-Condensed	GillSans Condensed	GillSans Condensed
GillSans-BoldCondensed	GillSans BoldCondensed	GillSans Condensed, Bold
GillSans-ExtraBold	GillSans ExtraBold	GillSans ExtraBold
Goudy	Goudy	Goudy
Goudy-Bold	Goudy Bold	Goudy, Bold
Goudy-Italic	Goudy Italic	Goudy, Italic
Goudy-BoldItalic	Goudy BoldItalic	Goudy, Bold Italic
Goudy-ExtraBold	Goudy ExtraBold	Goudy ExtraBold
Helvetica	Helvetica	Helvetica
Helvetica-Bold	Helvetica Bold	Helvetica, Bold
Helvetica-Oblique	Helvetica Oblique	Helvetica, Italic
Helvetica-BoldOblique	Helvetica BoldOblique	Helvetica, Bold Italic
Helvetica-Narrow	Helvetica Narrow	Helvetica-Narrow
Helvetica-Narrow-Bold	Helvetica Narrow Bold	Helvetica-Narrow, Bold
Helvetica-Narrow-Oblique	Helvetica Narrow Oblique	Helvetica-Narrow, Italic
Helvetica-Narrow-BoldOblique	Helvetica Narrow BoldObl	Helvetica-Narrow, Bold Italic
Helvetica-Condensed	Helvetica Condensed	Helvetica Condensed
Helvetica-Condensed-Bold	Helvetica CondensedBold	Helvetica Condensed, Bold
Helvetica-Condensed-Oblique	Helvetica CondensedOblique	Helvetica Condensed, Italic
Helvetica-Condensed-BoldObl	Helvetica CondensedBoldObl	Helvetica Condensed, Bold Italic
HoeflerText-Ornaments	Hoefler Text Ornaments	Hoefler Text Ornaments

B

B-4 Font List

PostScript name	Mac OS menu name	Windows menu name, style
JoannaMT	Joanna MT	Joanna MT
JoannaMT-Bold	Joanna MT Bd	Joanna MT, Bold
JoannaMT-Italic	Joanna MT It	Joanna MT, Italic
JoannaMT-BoldItalic	Joanna MT Bd It	Joanna MT, Bold Italic
LetterGothic	Letter Gothic	Letter Gothic
LetterGothic-Bold	Letter Gothic Bold	Letter Gothic, Bold
LetterGothic-Slanted	Letter Gothic Slanted	Letter Gothic, Italic
LetterGothic-BoldSlanted	Letter Gothic BoldSlanted	Letter Gothic, Bold Italic
LubalinGraph-Book	Lubalin Graph	LubalinGraph
LubalinGraph-Demi	Lubalin Graph Demi	LubalinGraph, Bold
LubalinGraph-BookOblique	Lubalin Graph BookOblique	LubalinGraph, Italic
LubalinGraph-DemiOblique	Lubalin Graph DemiOblique	LubalinGraph, Bold Italic
Marigold	Marigold	Marigold
MonaLisa-Recut	Mona Lisa Recut	Mona Lisa Recut
NewCenturySchlbk-Roman	New Century Schlbk	NewCenturySchlbk
NewCenturySchlbk-Bold	New Century Schlbk Bold	NewCenturySchlbk, Bold
NewCenturySchlbk-Italic	New Century Schlbk Italic	NewCenturySchlbk, Italic
NewCenturySchlbk-BoldItalic	New Century Schlbk BoldIt	NewCenturySchlbk, Bold Italic
Optima	Optima	Optima
Optima-Bold	Optima Bold	Optima, Bold
Optima-Italic	Optima Italic	Optima, Italic
Optima-BoldItalic	Optima BoldItalic	Optima, Bold Italic
Oxford	Oxford	Oxford
Palatino-Roman	Palatino	Palatino
Palatino-Bold	Palatino Bold	Palatino, Bold
Palatino-Italic	Palatino Italic	Palatino, Italic
Palatino-BoldItalic	Palatino BoldItalic	Palatino, Bold Italic
StempelGaramond-Roman	StempelGaramond Roman	StempelGaramond Roman
StempelGaramond-Bold	StempelGaramond Bold	StempelGaramond Roman, Bold

PostScript name	Mac OS menu name	Windows menu name, style
StempelGaramond-Italic	StempelGaramond Italic	StempelGaramond Roman, Italic
StempelGaramond-BoldItalic	StempelGaramond BoldItalic	StempelGaramond Roman, Bold Italic
Symbol	Symbol	Symbol
Tekton	Tekton	Tekton
Times-Roman	Times	Times
Times-Bold	Times Bold	Times, Bold
Times-Italic	Times Italic	Times, Italic
Times-BoldItalic	Times BoldItalic	Times, Bold Italic
TimesNewRomanPS-BoldMT	Times New Roman Bold	Times New Roman, Bold
TimesNewRomanPS-BoldItalicMT	Times New Roman Bold Italic	Times New Roman, Bold Italic
TimesNewRomanPS-ItalicMT	Times New Roman Italic	Times New Roman, Italic
TimesNewRomanPSMT	Times New Roman	Times New Roman
Univers-Extended	Univers Extended	Univers Extended
Univers-BoldExt	Univers BoldExt	Univers Extended, Bold
Univers-ExtendedObl	Univers ExtendedObl	Univers Extended, Italic
Univers-BoldExtObl	Univers BoldExtObl	Univers Extended, Bold Italic
Univers-Light	Univers 45 Light	Univers 45 Light
Univers-Bold	Univers 65 Bold	Univers 45 Light, Bold
Univers-LightOblique	Univers 45 LightOblique	Univers 45 Light, Italic
Univers-BoldOblique	Univers 65 BoldOblique	Univers 45 Light, Bold Italic
Univers	Univers 55	Univers 55
Univers-Oblique	Univers 55 Oblique	Univers 55, Italic
Univers-CondensedBold	Univers 67 CondensedBold	Univers 47 CondensedLight, Bold
Univers-CondensedBoldOblique	Univers 67 CondensedBoldObl	Univers 47 CondensedLight, Bold Italic
Univers-Condensed	Univers 57 Condensed	Univers 57 Condensed

PostScript name	Mac OS menu name	Windows menu name, style
Univers-CondensedOblique	Univers 57 CondensedOblique	Univers 57 Condensed, Italic
ZapfChancery-MediumItalic	Zapf Chancery	ZapfChancery
ZapfDingbats	Zapf Dingbats	ZapfDingbats

TrueType fonts

The Fiery includes 10 TrueType fonts:

PostScript name	Mac OS menu name	Windows menu name, style
Apple-Chancery	Apple Chancery	Apple Chancery
Chicago	Chicago	Chicago
Geneva	Geneva	Geneva
HoeflerText-Black	Hoefler Text Black	Hoefler Text Black
HoeflerText-BlackItalic	Hoefler Text Black	Hoefler Text Black, Italic
HoeflerText-Italic	Hoefler Text	Hoefler Text, Italic
HoeflerText-Regular	Hoefler Text	Hoefler Text
Monaco	Monaco	Monaco
New York	New York	New York
Wingdings-Regular	Wingdings	Wingdings

Appendix C: Troubleshooting

This appendix provides troubleshooting tips.

Maintaining optimal system performance

The Fiery does not require maintenance. Beyond the routine requirements of servicing and maintaining the copier and replenishing consumables, you can improve the overall performance of your system by doing the following:

- Check job ticket information carefully before printing.

Print jobs with the same output and paper specifications together, to minimize paper changes. Also, print routine jobs while you prepare to print jobs with special instructions or special media.

- Reduce unnecessary server connections to Command WorkStation.

If you use a second or third Fiery on an occasional basis, you can improve performance by logging off when those systems that are not in use.

- Avoid printing with the Fiery “Disk full” warning.

If you see this warning, delete jobs that are not likely to be reused. Avoid this condition by deleting old jobs on a regular basis. The date associated with a job is the original date it was sent.

Troubleshooting

This section provides some troubleshooting guidelines should a problem arise. If you are unable to resolve a problem after referring to this section, contact your site operator or administrator. Also, make sure there are no applications installed on the Fiery, with the exception of the Fiery utilities from the User Software CD. Applications other than the Fiery utilities are not supported and can cause system problems.



General printing problems

If this happens	Try this
You cannot connect to the Fiery.	<ul style="list-style-type: none">• Make sure the Fiery is not being calibrated from the Control Panel. If the Fiery is being calibrated from the Control Panel, you can select it in the Chooser, but you cannot connect to it. This ensures that only one person is calibrating the Fiery at any time and that print jobs do not use unexpected calibration.
You cannot select or view one of the queues.	<ul style="list-style-type: none">• Request that your system administrator enable the queue in Setup.
You cannot connect to the Fiery from a Windows computer with Command WorkStation or the Fiery utilities.	<ul style="list-style-type: none">• Make sure the connection is configured correctly. For instructions, see the <i>User Software Installation Guide</i>.
Printing seems to take too long.	<ul style="list-style-type: none">• Print to a queue instead of to the Direct connection. When you print to a queue, the job is stored on the Fiery until it can be processed and printed; when you print to the Direct connection, the job cannot be sent to the Fiery until the previous job is finished processing, so you must wait longer to use your computer.



If this happens	Try this
One or more Media Type options are dimmed.	<ul style="list-style-type: none">• Select a Paper Source that supports the Media Type you are using. For information on requirements and constraints pertaining to special papers and transparencies, see Appendix A.
The Fiery does not respond to a Print command.	<ul style="list-style-type: none">• Make sure the copier was not disconnected. If the administrator or operator has selected Suspend Printing on the Fiery Control Panel or Command WorkStation to interrupt printing, your print job will not resume until someone selects Resume Printing from the Functions menu on the Control Panel or clicks the function key on Command WorkStation.• Make sure the Fiery is selected as the current copier. Before printing, you must select the Fiery as the current printer from your Windows computer, Mac OS computer, or UNIX workstation.• Make sure the copier is switched on. Someone may have turned the copier off, or the Power Saver mode function may have engaged. Even with the copier off, the Fiery appears in the Chooser as long as the Fiery itself is turned on.• If you are printing over an IPX (Novell) network, verify through the PCONSOLE utility that the job was sent to the Novell queue and that the queue is being used by the Fiery.• Make sure the job does not contain a PostScript error. Contact the operator, or use Fiery WebSpooler or Fiery Spooler to check job status. In Fiery WebSpooler or Fiery Spooler, a job containing a PostScript error appears in red. To obtain information on the PostScript error, make sure the Print to PS Error option is set to Yes in Fiery Setup. For more information, see the Configuration Guide.
You cannot print with QuarkXPress 3.32 using the PSPrinter 8.7.2 driver on a Mac OS computer.	<ul style="list-style-type: none">• Remove the file called Balloon Help from your QuarkXPress application folder and restart QuarkXPress.



Problems with print quality

For information about printing with specific applications and optimizing color output, see the *Color Guide*.

If this happens	Try this
Print settings for your job output do not match the settings you gave.	<ul style="list-style-type: none">• Make sure you did not override the settings for the job in another place. For information about options and overrides, see Appendix A.
You have poor printing results.	<ul style="list-style-type: none">• Check if your application requires one of the Fiery's printer description files. Your application may require the Fiery PPD. If you print from Adobe PageMaker, make sure the Fiery PPD is installed correctly. For information about installing this file, see the <i>User Software Installation Guide</i>.• Make sure the system has been calibrated. For instructions, see the <i>Color Guide</i>.
The registration or colors of an image are not what you expected.	<ul style="list-style-type: none">• Ask the operator to print a Test Page with the copier. The problem may be with the copier. If your Test Page shows that the copier is working properly, correct the problem within your application. If the Test Page is wrong, your copier may need to be adjusted.
Your printed file appears too dark.	<ul style="list-style-type: none">• Adjust the Brightness option. You can use the Brightness option when printing from an application or from Fiery Downloader to lighten your image whenever you print a PostScript or Encapsulated PostScript (EPS) file.
Color file prints in black and white.	<ul style="list-style-type: none">• In the Color Matching dialog box, make sure that Color/Grayscale, or ColorSync Color Matching or PostScript Color Matching is selected (not Black and White).• Make sure the Color Mode print option is set to an option other than Grayscale.
Desktop Color Separations (DCS) format images print incorrectly.	<ul style="list-style-type: none">• Make sure you selected the correct options to send separations in the application's Print dialog box.• Make sure you have the file for every layer of separation that you are printing.• Set the Combine Separations option to On. This combines the high-resolution files for an image and prints them. With Combine Separations Off, the low-resolution master file will print.



If this happens	Try this
QuickDraw fill patterns print as solids.	<ul style="list-style-type: none">• Use the Adobe PostScript Printer driver (or the Apple LaserWriter 8.3 or later printer driver).

Problems with Fiery Downloader

If this happens	Try this
General problems.	<ul style="list-style-type: none">• Make sure you are using the latest version. If you are updating your Fiery to new system software, delete the previous version of Fiery Downloader from your Windows or Mac OS computer and install the latest version to ensure full compatibility.• Make sure the connection is configured correctly. For instructions, see the <i>User Software Installation Guide</i>.
You cannot print an EPS file using Fiery Downloader.	<ul style="list-style-type: none">• Try printing using the ‘showpage’ after EPS files (Windows) or ‘showpage’ (Mac OS) option in the Download PostScript File dialog box. This option adds a showpage PostScript language command at the end of the print job. Certain applications omit this necessary command when they generate EPS files. You must select the Append Showpage option when printing EPS files generated by these applications. If you continue having difficulties printing an EPS file with Fiery Downloader, try printing the file from the application in which it was created.• Make sure the EPS file was saved <i>without</i> a preview image header. Preview image headers are useful when images are placed in documents with page layout applications, but they cause problems when images are downloaded directly.• Make sure the job does not contain a PostScript error. Contact the operator or use Command WorkStation, Fiery WebSpooler, or Fiery Spooler to check the job’s status. Jobs with a PostScript error appear with an Error icon.
You have problems downloading a font with Fiery Downloader.	<ul style="list-style-type: none">• Check with the administrator to make sure that the Direct connection is enabled. The Direct connection must be used to download fonts.
An extra blank page prints after a Fiery Downloader job.	<ul style="list-style-type: none">• Turn off the ‘showpage’ after EPS files (Windows) or ‘showpage’ (Mac OS) option. This option adds a special PostScript command that will cause an extra blank page to print if it is not necessary.



Problems with Fiery Scan

If this happens:	Try this
Fiery Scan main window does not appear after launching.	<ul style="list-style-type: none">• Check to see if the TWAIN module(s) installed by Adobe Photoshop are located in the correct folder. If not, reinstall Adobe Photoshop software.

Problems with Fiery WebTools

If this happens	Try this
General problems.	<ul style="list-style-type: none">• Clear the cache (Netscape Communicator) or history (Microsoft Internet Explorer).

Index

A

- Adobe Photoshop
 - scanning with 6-2
 - transfer functions 4-7
- Adobe Type 1 fonts B-1

B

- Black Detection option A-4
- Black Overprint option A-4
- Brightness option A-2, A-4
- BSD 3-2

C

- CMYK Simulation Method option A-4
- CMYK Simulation Profile option A-5
- Collate option A-5
- Color Mode option A-5
- ColorWise Pro Tools
 - job overrides A-2
- Combine Separations option A-5
- Command WorkStation
 - managing print jobs 7-1
 - overriding FreeForm Master number 5-3
 - overriding Printer Setup settings 1-6
- Create Master option 5-2
- Custom Page Sizes
 - defining for Windows 2000/XP 1-20
 - defining for Windows NT 4.0 1-14, 1-17, 1-20
- Custom Paper Sizes
 - defining for Mac OS 2-7

D

- DCS (Desktop Color Separations) C-4
- Direct connection
 - downloading fonts 4-9
 - not in Chooser, Mac OS 2-2
 - required to download fonts C-5
- Duplex option A-11, A-12

E

- EFIRGB ICC file 6-1
- EFIRGB.icm file 6-1
- EPS (Encapsulated PostScript) files
 - downloading 4-1
 - downloading from Windows 1-1
 - problems downloading C-5

F

- Fiery Downloader
 - Brightness option 4-7
 - choosing a printer 4-3
 - Connection Type 4-5
 - Download Progress bar 4-2
 - downloading file or font 4-4 to 4-7
 - Hard Disk area 4-2
 - installing printer fonts 4-10
 - job overrides A-2
 - PDF files 1-1
 - Print Status area 4-2
 - problems with C-5
 - Queue 4-5
 - RIP Status area 4-2
 - Toolbar 4-3
 - using 4-1
- Fiery Remote Scan
 - retrieving scans 6-2
 - sending to the Hold queue 6-5
- Fiery Scan
 - problems with C-6
- Fiery WebTools
 - accessing 7-1
 - home page 7-2, 7-5
 - overview 7-3
 - problems with C-6
 - WebLink 7-3

Fiery E-mail Service
 about 8-1
 Job Control 8-4
 managing print jobs 8-4
 printing using an E-mail client 8-2
 printing using the E-mail Port
 Monitor 8-4

File name entry field 4-6

File port, saving files to 1-22

Files of type menu (Windows) 4-5

font list
 Adobe Type 1 B-1
 displaying 4-3, 4-11
 PostScript B-1 to B-6
 printing 4-3, 4-11
 TrueType B-6

Font List button 4-3

fonts
 Adobe Type 1 4-10, B-1
 downloading and managing 4-1, 4-5
 installing 4-10
 PostScript 4-10
 printer fonts 4-10
 printer fonts on server 4-11
 screen fonts 4-10
 substitution with PDF files 4-10
 TrueType B-6

FreeForm
 Master number 5-3

G

Gamma option A-7

H

Hold queue 2-2

I

installing printer fonts 4-10
 Instructions field 1-5

J

job overrides
 (Other) Gamma option A-7
 (Other) Phosphors option A-7
 (Other) White Point option A-7
 Black Detection option A-4
 Black Overprint option A-4
 Brightness option A-4
 CMYK Simulation Method option A-4
 CMYK Simulation Profile option A-5
 Collate option A-5
 Color Mode option A-5
 Combine Separations option A-5
 Duplex option A-11
 Page Order option A-8
 print settings A-2
 Pure Black Text Graphics option A-8
 Rendering Style option A-8
 Slip Sheet option A-9
 Spot Color Matching option A-10

Job Templates 1-7

L

LaserWriter printer, fonts installed on 4-10

lp command 3-2

lpq command 3-1, 3-2, 3-3

lpr command 3-1, 3-2

lprm command 3-1, 3-3

lpstat command 3-2

M

Mac OS
 Paper Source menu 2-4
 PostScript printer setup 2-3 to 2-7
 Printer Specific Options menu 2-6
 printing 2-1
 screen fonts 4-10
 tray selection 2-4

N

Notes fields
 Windows 1-5

O

- (Other) Gamma option A-7
- (Other) Phosphors option A-7
- (Other) White Point option A-7
- Output Profile option A-7
- overrides, of job settings A-2

P

- Page Order option A-8
- Page Range option A-2
- Paper Source menu
 - Mac OS 2-4
- PDF files
 - downloading 4-1
 - downloading from Windows 1-1
 - font substitution 4-10
- performance, optimizing C-1
- Phosphors option A-7
- Portable Document Format, *see* PDF files
- PostScript
 - downloading files 4-1
 - font list B-1 to B-6
- PostScript printer description files, *see* PPDs
- PostScript printer drivers
 - explained A-1
 - Mac OS 2-1
 - Windows 1-2
- PPDs (PostScript printer description files)
 - options A-2
 - setting print options with Mac OS 2-1
- Print command (Windows) 1-1
- print options
 - Mac OS 2-3 to 2-7
 - Windows 1-2 to 1-6
- print quality, problems with C-4
- printer default settings
 - where to set A-2
 - Windows 1-6
- printer setup
 - Mac OS 2-3 to 2-7
 - Windows 1-2 to 1-6

Printer Specific Options menu 2-6

printing

- duplex pages A-11, A-12
- font list 4-3
- Mac OS 2-1
- to File port 1-22
- troubleshooting C-2 to C-3
- Windows 1-2

Pure Black Text Graphics option A-8

R

- Rendering Style option A-8
- RGB Separation option A-8
- RIPping A-1

S

- Scanning
 - Fiery Remote Scan 6-2
- scanning
 - from the copier glass 6-1
- Shortcuts 1-12
- Show menu (Mac OS) 4-5
- showpage after EPS files option 4-7
- Slip Sheet option A-9
- SMB printing 1-2
- Solaris 2.x 3-2
- Spot Color Matching option A-10
- SunOS 4.1.x 3-2

T

- TCP/IP printing 3-1
- tray selection
 - Mac OS 2-4
- troubleshooting
 - EPS files C-5
 - Fiery Downloader C-5
 - Fiery Scan C-6
 - Fiery WebTools C-6
 - general printing problems C-2 to C-3
 - print quality C-4
- TrueType fonts B-6

U

UNIX

- BSD (Berkeley Software Distribution)
 - variant of 3-3
- displaying jobs in queue 3-2
- printing with 3-1
- removing jobs from queue 3-3
- System V 3-2
- Use Master option 5-2

W

- WebLink, *see* Fiery WebTools
- White Point option A-7
- Windows
 - Notes fields 1-5
 - PostScript printer driver 1-2
 - printer default settings 1-6
 - printing with 1-2
 - setting print options 1-2 to 1-6