

DATA SHEET

SURFACE-MOUNT CERAMIC MULTILAYER CAPACITORS

General data



PACKING

TAPE AND REEL SPECIFICATIONS

Packing conforms fully with “IEC 60286-3”, “EIA 481-1” and “JIS C0806” industrial standards.

Multilayer Chip Capacitors (MLCCs) are supplied on tape on reel or in bulk case. For MLCCs with a product thickness of <1 mm, paper/PE tape is preferred. MLCCs with a product thickness of ≥ 1 mm, are supplied in embossed blister tape.

For the combination carrier/cover tape no electrostatic behaviour is observed (relative humidity ≥ 30%). The products do not stick to the cover tape. The technical and thermal properties of polycarbonate tapes are excellent, so there is no change in dimensions as a function of time. The peel off force is very stable as a function of time and temperature, and it is defined as 0.1 to 0.7 N at a peel-off speed of 300 mm/minute.

Table 1 Properties of carrier tape - polycarbonate
8.1/12 MM TAPE WIDTH, 0.2 MM TOLERANCE

Thickness	130 to 360 μm
Tensile strength at break	> 60 MPa
Elongation at break	100 to 150%
Surface resistance	< 10 ¹² Ω/sq.

Table 2 Properties of cover tape - polyester (antistatic)
5.5/9.5 MM TAPE WIDTH, 0.1 MM TOLERANCE

Thickness	62 μm
Breaking force	> 20 N / ≥ 17.6 N
Elongation at break	105 ±60%
Surface resistance	< 10 ¹¹ Ω/sq.

BULK-CASE SPECIFICATION

In accordance with “IEC 60286-6”.

Reduced costs

- Storage
- Transport
- Machine handling
- Packing

Customized labelling (bar codes)

Available component size please see table 3

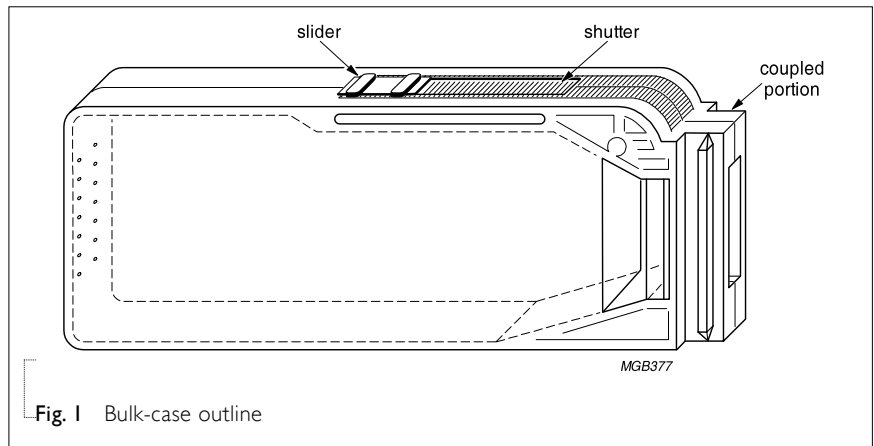

Fig. 1 Bulk-case outline

OUTLINES

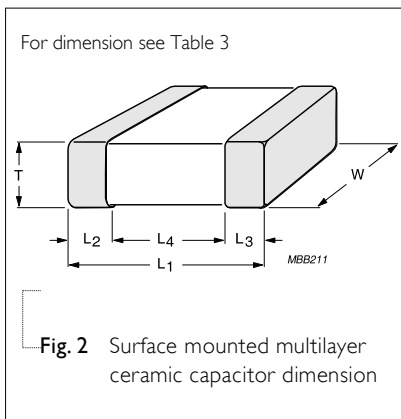

Table 3 Packing quantities for component size; see note 1 and Fig. 1

SIZE CODE	L ₁ (mm)	W (mm)	T (mm)	QUANTITY PER BULK CASE
0402	1.0	0.5	0.5	50,000
0603	1.6	0.8	0.8	15,000
0805	2.0	1.25	0.6	10,000
0805	2.0	1.25	0.85	8,000
0805	2.0	1.25	1.25	5,000

NOTE

1. Refer to the selection charts in product data for specific values

PAPER/PE TAPE SPECIFICATION

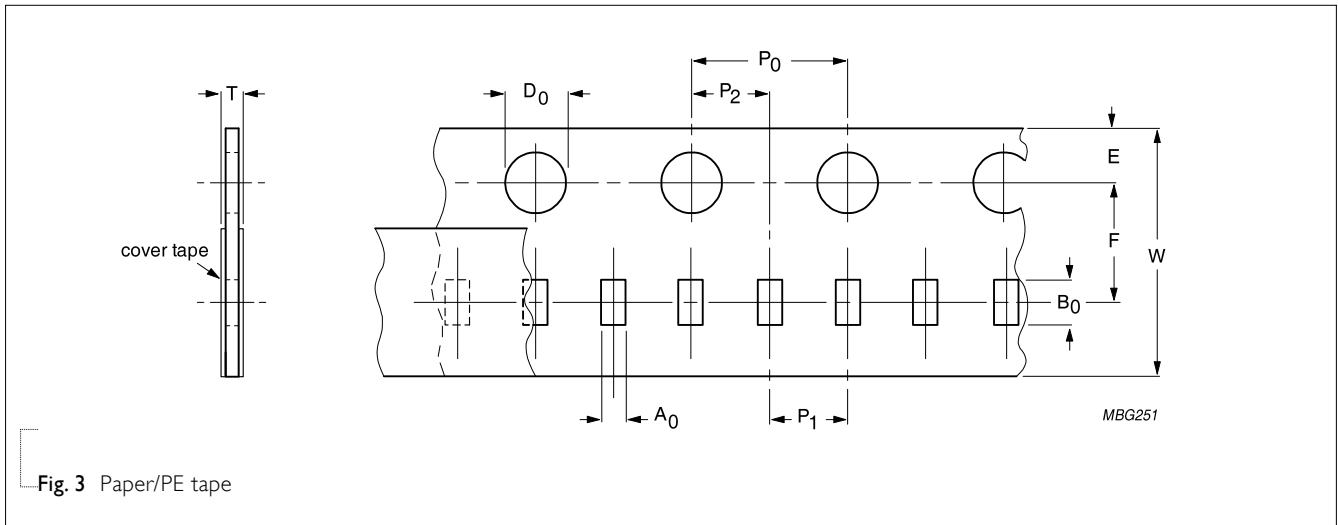

Fig. 3 Paper/PE tape

Table 4 Dimensions of paper/PE tape for relevant chip size; see Fig.3

SIZE CODE	SYMBOL										Unit: mm
	A ₀	B ₀	W	E	F	P ₀ ⁽¹⁾	P ₁	P ₂	ØD ₀	T	
01005	0.23 ± 0.02	0.43 ± 0.02	8.0 ± 0.20	1.70 ± 0.05	3.50 ± 0.05	4.0 ± 0.10	2.0 ± 0.05	2.0 ± 0.05	1.50 ± 0.1	0.31 ± 0.02	
0201	0.37 ± 0.03	0.69 ± 0.05	8.0 ± 0.20	1.75 ± 0.1	3.50 ± 0.05	4.0 ± 0.10	2.0 ± 0.05	2.0 ± 0.05	1.55 ± 0.03	0.42 ± 0.05	
0402	0.65 ± 0.15	1.10 ± 0.15	8.0 ± 0.20	1.75 ± 0.1	3.50 ± 0.05	4.0 ± 0.05	2.0 ± 0.05	2.0 ± 0.05	1.50 +0.1 /-0	0.60 ± 0.10	
0603	0.95 ± 0.15	1.78 ± 0.15	8.0 ± 0.20	1.75 ± 0.1	3.50 ± 0.05	4.0 ± 0.05	4.0 ± 0.05	2.0 ± 0.05	1.50 +0.1 /-0	0.95 ± 0.15	
0805	1.50 ± 0.15	2.26 ± 0.20	8.0 ± 0.20	1.75 ± 0.1	3.50 ± 0.05	4.0 ± 0.05	4.0 ± 0.05	2.0 ± 0.05	1.50 +0.1 /-0	(0.95 / 0.75)± 0.10	
1206	1.90 ± 0.15	3.50 ± 0.20	8.0 ± 0.20	1.75 ± 0.1	3.50 ± 0.05	4.0 ± 0.05	4.0 ± 0.05	2.0 ± 0.05	1.50 +0.1 /-0	(0.95 / 0.75)± 0.10	
4 × 0402	1.50 ± 0.15	2.26 ± 0.20	8.0 ± 0.20	1.75 ± 0.1	3.50 ± 0.05	4.0 ± 0.05	4.0 ± 0.05	2.0 ± 0.05	1.50 +0.1 /-0	(0.95 / 0.75)± 0.10	
4 × 0603	1.90 ± 0.15	3.50 ± 0.20	8.0 ± 0.20	1.75 ± 0.1	3.50 ± 0.05	4.0 ± 0.05	4.0 ± 0.05	2.0 ± 0.05	1.50 +0.1 /-0	(0.95 / 0.75)± 0.10	
0508	1.50 ± 0.15	2.26 ± 0.20	8.0 ± 0.20	1.75 ± 0.1	3.50 ± 0.05	4.0 ± 0.05	4.0 ± 0.05	2.0 ± 0.05	1.50 +0.1 /-0	(0.95 / 0.75)± 0.10	
0612	1.90 ± 0.15	3.50 ± 0.20	8.0 ± 0.20	1.75 ± 0.1	3.50 ± 0.05	4.0 ± 0.05	4.0 ± 0.05	2.0 ± 0.05	1.50 +0.1 /-0	(0.95 / 0.75)± 0.10	

NOTE

1. P₀ pitch tolerance over any 10 pitches is ±0.2 mm
2. 4 × 0402 stands for 0508 array
3. 4 × 0603 stands for 0612 array

BLISTER TAPE SPECIFICATION

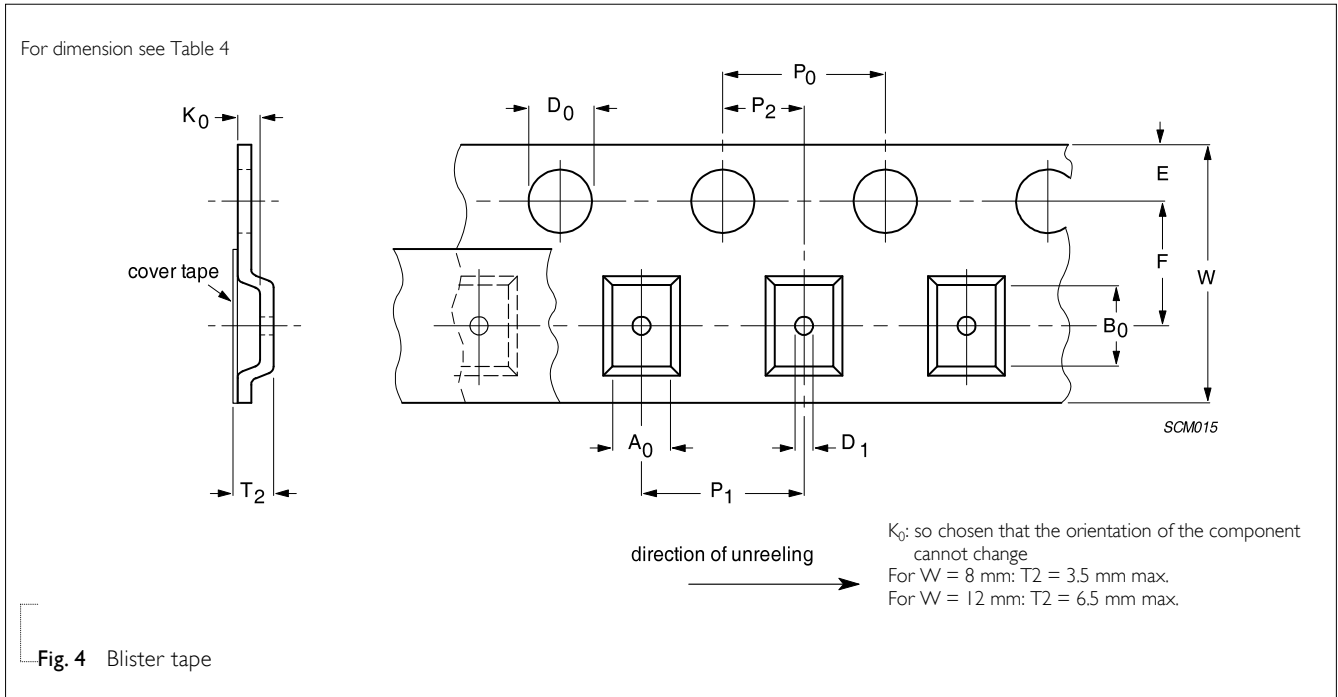

Table 5 Dimensions of blister tape for relevant chip size; see Fig.4

SIZE CODE	SYMBOL											Unit: mm		
	A ₀		B ₀		K ₀		W	E	F	ØD ₀	ØD ₁	P ₀ ⁽²⁾	P ₁	P ₂
	Min.	Max.	Min.	Max.	Min.	Max.					Min.			
0805	1.29	1.65	2.15	2.60	1.25	1.55	8.1 ±0.20	1.70 ±0.1	3.5 ±0.05	1.5 +0.1/-0.0	1 +0.1/-0.0	4.0 ±0.10	4.0 ±0.10	2.0 ±0.05
1206	1.70	2.00	3.40	3.75	1.22	2.15	8.1 ±0.20	1.70 ±0.1	3.5 ±0.05	1.5 +0.1/-0.0	1 +0.1/-0.0	4.0 ±0.10	4.0 ±0.10	2.0 ±0.05
1210	2.68	2.92	3.40	3.75	0.97	2.80	8.1 ±0.20	1.70 ±0.1	3.5 ±0.05	1.5 +0.1/-0.0	1 +0.1/-0.0	4.0 ±0.10	4.0 ±0.10	2.0 ±0.05
1808	2.05	2.42	4.85	5.20	1.35	2.35	12.1 ±0.20	1.70 ±0.1	5.5 ±0.05	1.5 +0.1/-0.0	1.5 +0.1/-0.0	4.0 ±0.10	4.0 ±0.10	2.0 ±0.05
1812	3.35	3.75	4.80	5.06	0.70	1.45	12.1 ±0.20	1.70 ±0.1	5.5 ±0.05	1.5 +0.1/-0.0	1.5 +0.1/-0.0	4.0 ±0.10	8.0 ±0.10	2.0 ±0.05
2220	5.12	5.32	5.84	6.04	1.28	1.48	12.0 ±0.20	1.70 ±0.1	5.5 ±0.05	1.5 +0.1/-0.0	1.5 +0.1/-0.0	4.0 ±0.10	8.0 ±0.10	2.0 ±0.05

NOTE

1. Typical capacitor displacement in pocket
2. P₀ pitch tolerance over any 10 pitches is ±0.2 mm

REEL SPECIFICATION

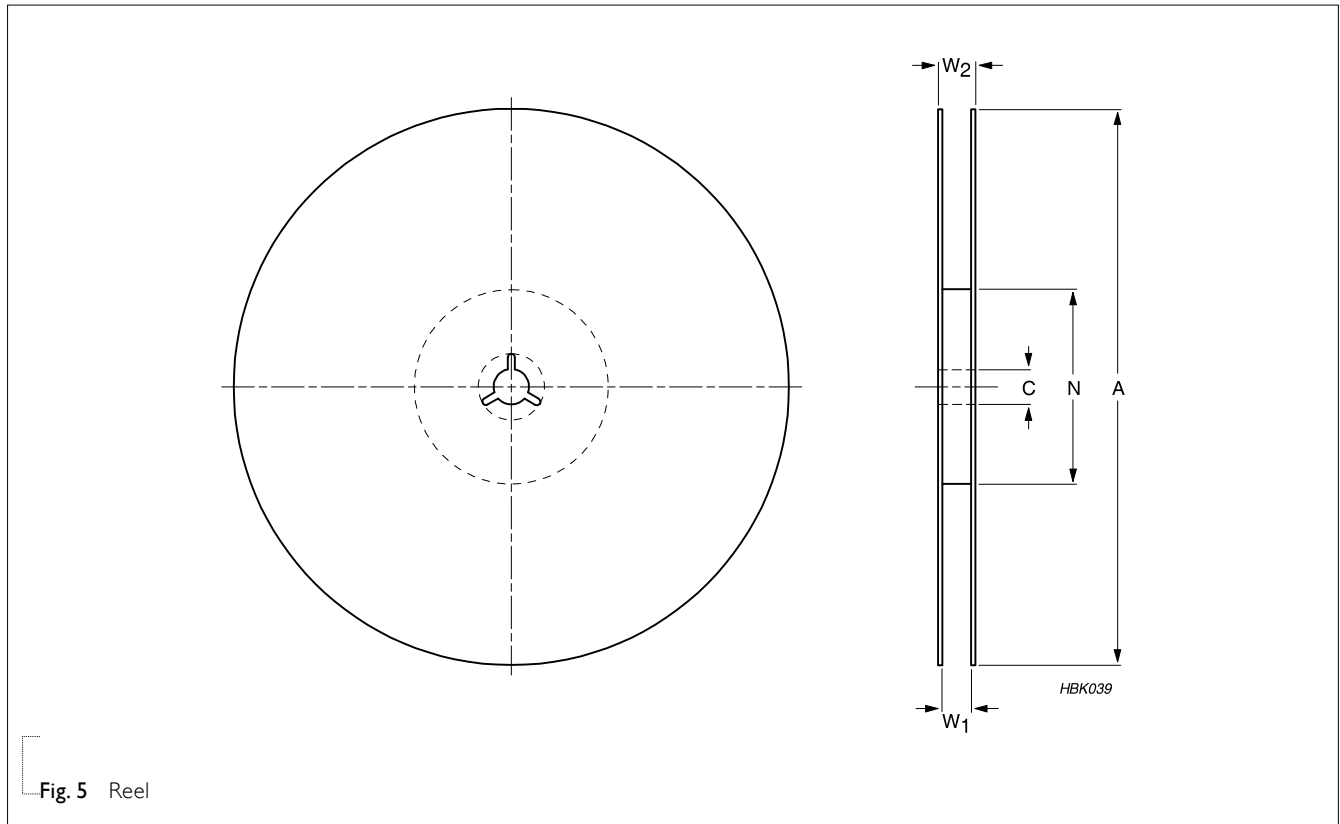

Fig. 5 Reel

Table 6 Reel dimensions; see Fig.5

TAPE WIDTH	SYMBOL					Unit: mm
	A	N	C	W ₁	W _{2max.}	
8 (Ø178 mm/7")	178 ±1.0	60 ±1.0	13 +0.50/-0.20	9.0 ±0.2	14.4	
8 (Ø330 mm/13")	330 ±1.0	100 ±1.0	13 +0.50/-0.20	9.0 ±0.2	14.4	
12 (Ø178 mm/7")	178 ±1.0	60 ±1.0	13 +0.50/-0.20	13.4 ±1.5	18.4	

PROPERTIES OF REEL

Material: polystyrene

Surface resistance: <math> <10^{10} \Omega/\text{sq}</math>.

THICKNESS CLASSES AND PACKING QUANTITY

Table 7

SIZE CODE	THICKNESS CLASSIFICATION	TAPE WIDTH QUANTITY PER REEL	Ø180 MM / 7 INCH		Ø330 MM / 13 INCH		QUANTITY PER BULK CASE
			Paper/PE	Blister	Paper/PE	Blister	
0201	0.3 ±0.03 mm	8 mm	15,000	---	50,000	---	---
0402	0.5 ±0.05 mm	8 mm	10,000	---	50,000	---	50,000
0603	0.8 ±0.1 mm	8 mm	4,000	---	15,000	---	15,000
0805	0.6 ±0.1 mm	8 mm	4,000	---	20,000	---	10,000
	0.85 ±0.1 mm	8 mm	4,000	---	15,000	---	8,000
	1.25 ±0.2 mm	8 mm	---	3,000	---	10,000	5,000
1206	0.6 ±0.1 mm	8 mm	4,000	---	20,000	---	---
	0.85 ±0.1 mm	8 mm	4,000	---	15,000	---	---
	1.00 / 1.15 ±0.1 mm	8 mm	---	3,000	---	10,000	---
	1.25 ±0.2 mm	8 mm	---	3,000	---	10,000	---
	1.6 ±0.15 mm	8 mm	---	2,500	---	10,000	---
	1.6 ±0.2 mm	8 mm	---	2,000	---	8,000	---
1210	0.6 / 0.7 ±0.1 mm	8 mm	---	4,000	---	15,000	---
	0.85 ±0.1 mm	8 mm	---	4,000	---	10,000	---
	1.15 ±0.1 mm	8 mm	---	3,000	---	10,000	---
	1.15 ±0.15 mm	8 mm	---	3,000	---	10,000	---
	1.25 ±0.2 mm	8 mm	---	3,000	---	---	---
	1.5 ±0.1 mm	8 mm	---	2,000	---	---	---
	1.6 / 1.9 ±0.2 mm	8 mm	---	2,000	---	---	---
	2.0 ±0.2 mm	8 mm	---	2,000 1,000	---	---	---
1808	1.15 ±0.15 mm	12 mm	---	3,000	---	---	---
	1.25 ±0.2 mm	12 mm	---	3,000	---	---	---
	1.35 ±0.15 mm	12 mm	---	2,000	---	---	---
	1.5 ±0.1 mm	12 mm	---	2,000	---	---	---
	1.6 ±0.2 mm	12 mm	---	2,000	---	---	---
	2.0 ±0.2 mm	12 mm	---	2,000	---	---	---
1812	0.6 / 0.85 ±0.1 mm	12 mm	---	2,000	---	---	---
	1.15 ±0.1 mm	12 mm	---	1,000	---	---	---
	1.25 ±0.2 mm	12 mm	---	1,000	---	---	---
	1.5 ±0.1 mm	12 mm	---	1,000	---	---	---
	1.6 ±0.2 mm	12 mm	---	1,000	---	---	---
	2.0 ±0.2 mm	12 mm	---	1,000	---	---	---
	2.5 ±0.2 mm	12 mm	---	500	---	---	---

LEADER/TRAILER TAPE SPECIFICATION

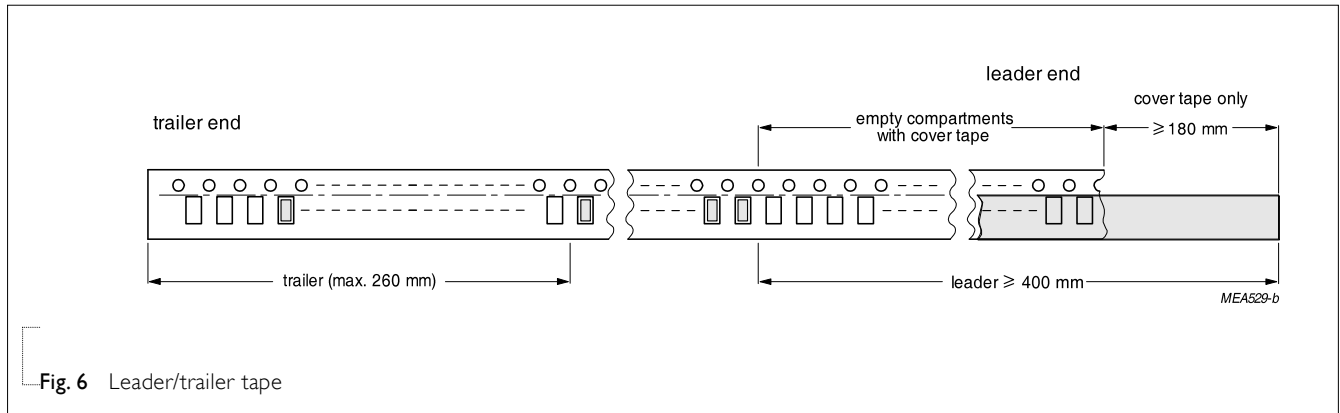

Fig. 6 Leader/trailer tape

Table 8 Leader/trailer tape data

DESCRIPTION	VALUE
Minimum length of empty compartments at leader end	≥ 400 mm of which a minimum 260 mm of empty compartments are covered with cover tape and ≥ 180 mm cover tape only
Minimum length of empty compartments at trailer end	≥ 180 mm

LABELLING

Label examples are shown in Fig. 7

LINE	MARKING EXPLANATION
1	Quantity
2	Bar code of batch no (1D)
3	Unique batch number
4	Bar code of CTC (2D)
5	Taping week code
6	Series code of reel

YNM0010

Fig. 7 Packing label

MOUNTING

SOLDER REPAIRS

Conventional solder repairs are carried out with a soldering iron as shown as Tab.9 . The tip of the soldering iron should not directly touch the chip component to avoid thermal shock on the interface between termination and body during mounting, repairing or de-mounting processes. Ensure the termination solder has melted before removing the chip component.

Table 9 Recommended soldering iron condition

TYPE	Temp(°C)	DURATION (SEC.)	PREHEATING TEMP(°C)	ATMOSPHERE
CC0201/CC0402/CC0603/CC0805/CC1206	350 max.	3 max.	150 min.	air
CC1210/CC1808/CC1812/CC2220	280 max.	3 max.	150 min.	air

SOLDERING CONDITIONS

For normal use the capacitors may be mounted on printed-circuit boards or ceramic substrates by applying wave soldering, reflow soldering or conductive adhesive in accordance with IEC 61760-1 (Standard method for the specification of surface mounting components). For advised soldering profiles see Figs 8, 9, 10.

An improper combination of soldering, substrate and chip size can lead to a damaging of the component. The risk increases with the chip size and with temperature fluctuations (>100 °C).

Therefore, it is advised to use the smallest possible size and follow the dimensional recommendations given in Tables 8, 9 and 10 for reflow and wave soldering. More detailed information is available on request.

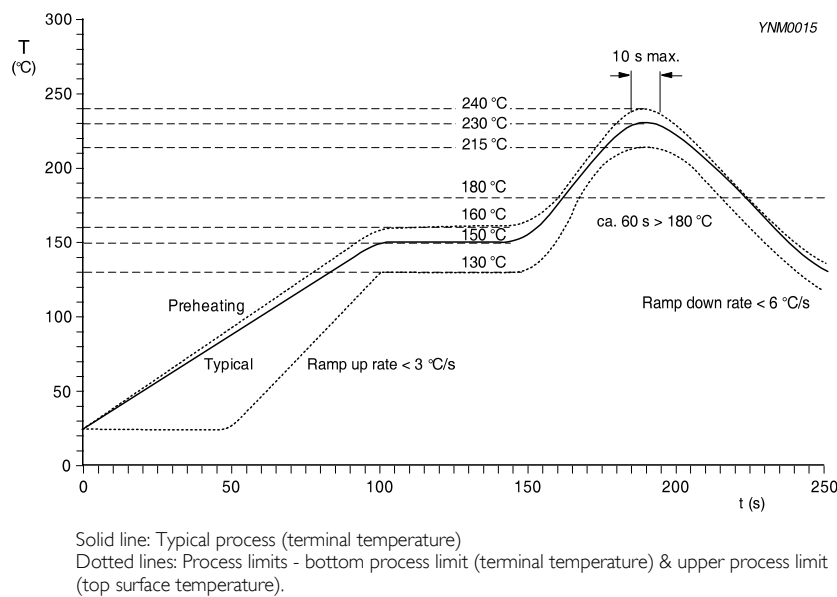

Fig. 8 Infrared soldering, forced gas convection reflow soldering - Temperature/time profile for SnPb solders

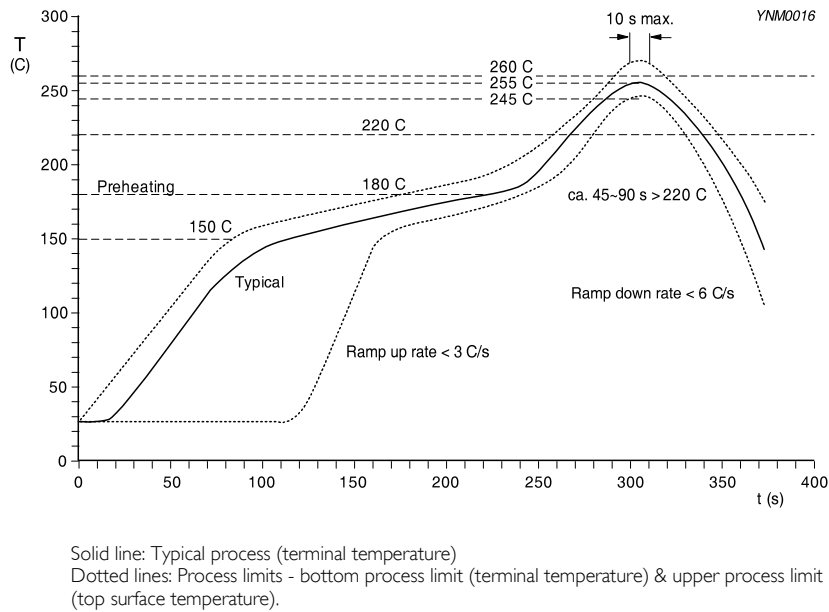

Fig. 9 Infrared soldering, forced gas convection reflow soldering - Temperature/time profile for lead-free SnAgCu solders

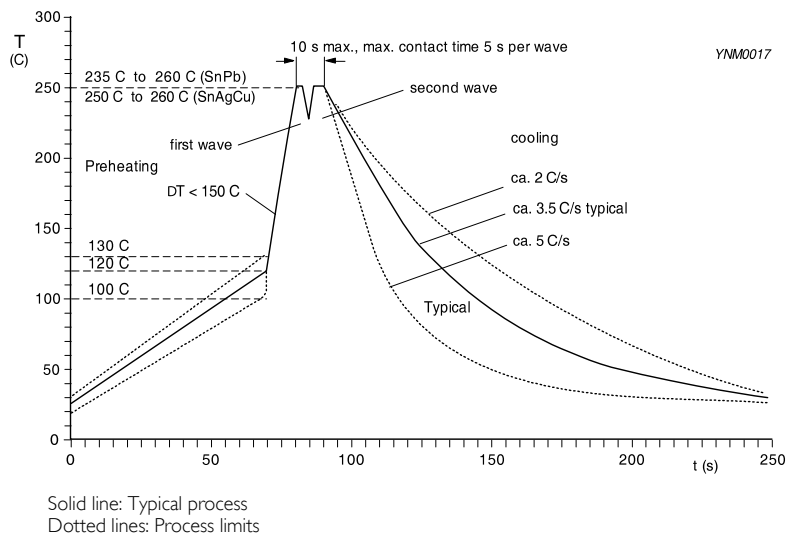

Fig. 10 Double wave soldering for SnPb and lead-free SnAgCu solder - Temperature/time profile (terminal temperature)

FOOTPRINT DIMENSIONS

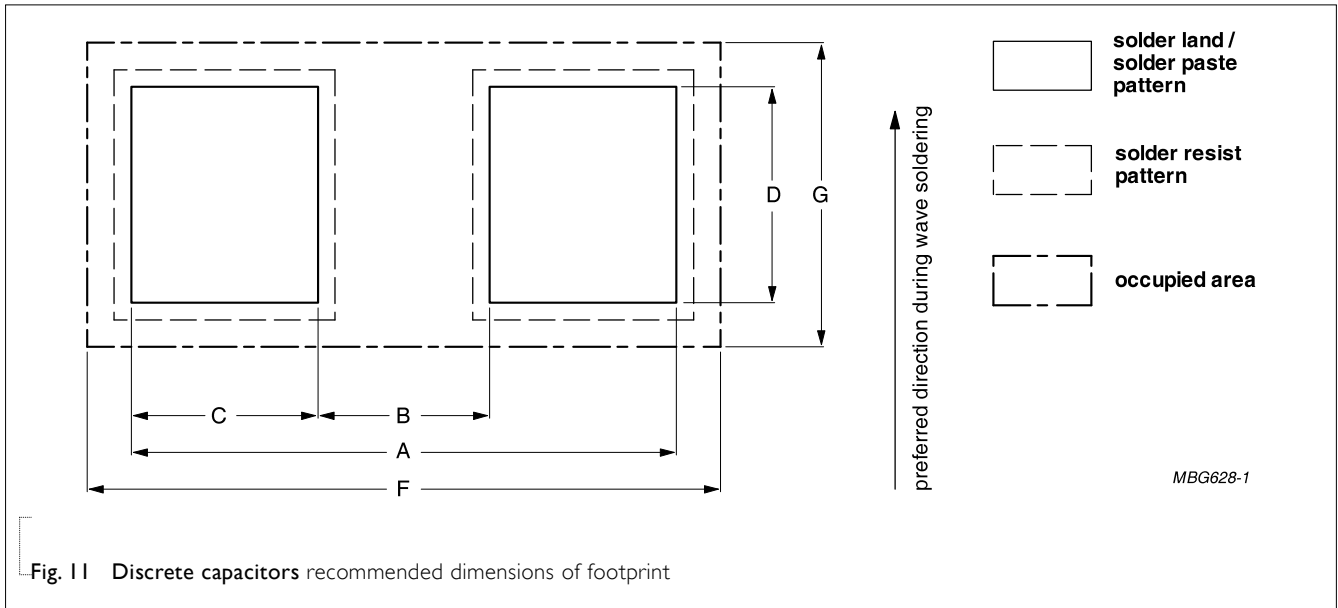

Fig. 11 Discrete capacitors recommended dimensions of footprint

Table 10 Reflow soldering; for footprint dimensions see Fig. 11

SIZE	FOOTPRINT DIMENSIONS						Unit: mm
CODE	A	B	C	D	F	G	Processing remarks
01005	0.48 ±0.08	0.18 ±0.02	0.15 ±0.03	0.215 ±0.15	---	---	
0201	0.8 ±0.20	0.25 ±0.05	0.28 ±0.07	0.3 ±0.10	---	---	
0402	1.5 ±0.15	0.5 ±0.15	0.5 ±0.15	0.5 ±0.15	1.75 ±0.15	0.95 ±0.15	
0603	2.3 ±0.15	0.7 ±0.15	0.8 ±0.15	0.9 ±0.15	2.7 ±0.15	1.5 ±0.15	
0603	2.3 ±0.25	0.5 ±0.25	0.9 ±0.25	0.9 ±0.25	2.7 ±0.25	1.5 ±0.25	IR or hot plate soldering
0805	2.8 ±0.25	0.9 ±0.25	0.95 ±0.25	1.4 ±0.25	3.2 ±0.25	2.1 ±0.25	
1206	4.0 ±0.25	2.0 ±0.25	1.0 ±0.25	1.8 ±0.25	4.4 ±0.25	2.5 ±0.25	
1210	4.0 ±0.25	2.0 ±0.25	1.0 ±0.25	2.7 ±0.25	4.4 ±0.25	3.4 ±0.25	
1808	5.4 ±0.25	3.3 ±0.25	1.05 ±0.25	2.3 ±0.25	5.8 ±0.25	2.9 ±0.25	
1812	5.4 ±0.25	3.3 ±0.25	1.05 ±0.25	3.5 ±0.25	5.8 ±0.25	4.1 ±0.25	
2220	6.6 ±0.25	4.5 ±0.25	1.05 ±0.25	5.3 ±0.25	7.0 ±0.25	5.9 ±0.25	
0204	0.55~0.65	0.15~0.20	0.2~0.25	0.7~1.0	0.95 ±0.15	1.75 ±0.15	Ceramic substrate only
0306	0.7~1.0	0.2~0.3	0.3~0.4	1.4~1.6	1.5 ±0.15	2.7±0.15	
0508	1.2~1.5	0.4~0.5	0.4~0.5	1.4~1.8	2.1 ±0.25	3.2 ±0.25	
0612	1.8~2.3	0.6~0.8	0.6~0.7	2.6~2.8	2.5 ±0.25	4.4 ±0.25	

Table 11 Wave soldering (no dummy tracks allowed for ≥ 500 V); for footprint dimensions see Fig.11

SIZE	FOOTPRINT DIMENSIONS						Unit: mm
CODE	A	B	C	D	F	G	Number & dimensions to dummy tracks
0603	2.4 ±0.10	1.0 ±0.10	0.7 ±0.10	0.8 ±0.10	3.0 ±0.10	1.9 ±0.10	1 × (0.2 × 0.8)
0603	2.7 ±0.25	0.9 ±0.25	0.9 ±0.25	0.8 ±0.25	3.2 ±0.25	2.1 ±0.25	1 × (0.3 × 0.8)
0805	3.2 ±0.15	1.4 ±0.15	0.9 ±0.15	1.3 ±0.15	4.1 ±0.15	2.5 ±0.15	1 × (0.3 × 1.3)
0805	3.4 ±0.25	1.3 ±0.25	1.05 ±0.25	1.3 ±0.25	4.3 ±0.25	2.7 ±0.25	1 × (0.2 × 1.3)
1206	4.8 ±0.25	2.3 ±0.25	1.25 ±0.25	1.7 ±0.25	5.9 ±0.25	3.2 ±0.25	3 × (0.25 × 1.7)
0508	1.3~2.1	0.4~0.7	0.5~0.7	1.4~1.8	2.5 ±0.15	4.1 ±0.15	---
0612	2.0~2.9	0.6~1.0	0.8~0.9	2.6~2.8	3.2 ±0.25	5.9 ±0.25	---

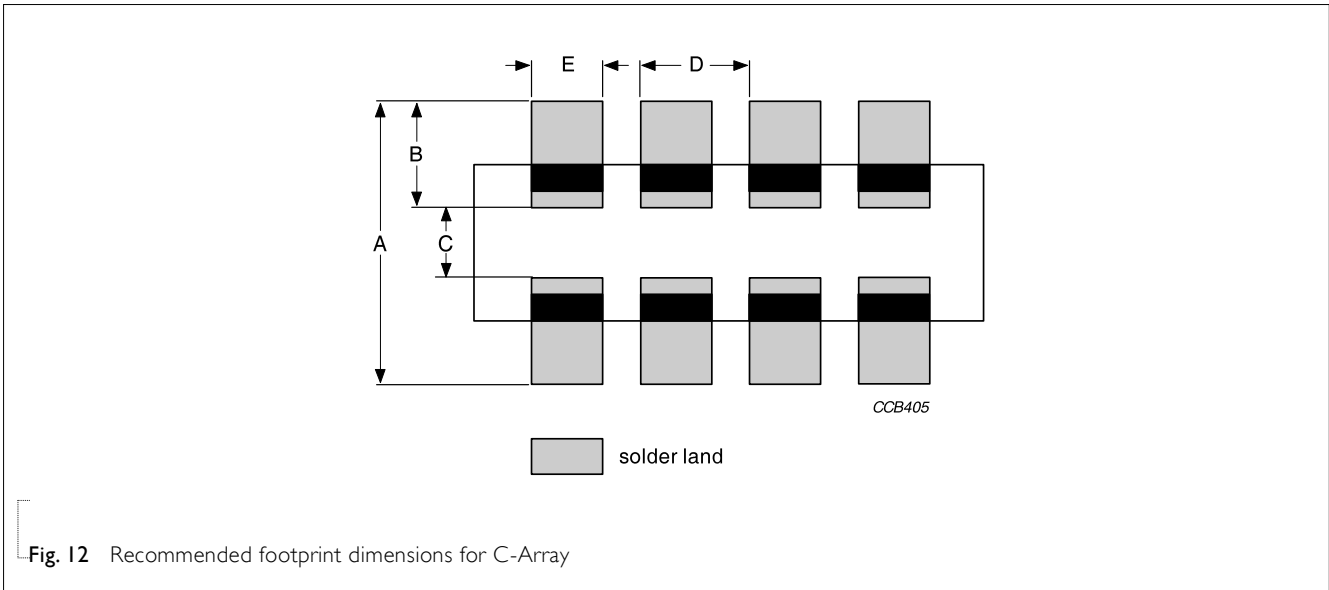

Fig. 12 Recommended footprint dimensions for C-Array

Table 12 C-Array footprint dimensions; see Fig.12

SIZE CODE	FOOTPRINT DIMENSIONS					Unit: mm
	A	B	C	D	E	
0405 (2 x 0402)	1.4 ±0.15	0.4 ±0.05	0.6 ±0.05	0.64	0.35 ±0.05	
0508 (4 x 0402)	1.65 ±0.15	0.55 ±0.05	0.55 ±0.05	0.5	0.25 ±0.05	
0612 (4 x 0603)	2.54 ±0.15	0.89 ±0.10	0.76 ±0.10	0.80 ±0.10	0.45 ±0.10	

REVISION HISTORY

REVISION	DATE	CHANGE NOTIFICATION
Version 24	May 7, 2018	- Dimensions of 1808 blister tape updated
Version 23	Jun.7, 2017	- Dimensions of blister tape updated
Version 22	Jan. 26, 2016	- Size update
Version 21	Oct. 19 2015	- Mounting update
Version 20	Sep. 09 2015	- Dimensions of paper
Version 19	Jan. 27 2015	- Dimensions of paper
Version 18	Jun. 10, 2014	- Dimensions of paper
Version 17	Jun. 17, 2013	- Thickness classes and Packing quantity updated
Version 16	Oct 05, 2012	- Thickness classes and Packing quantity updated
Version 15	Mar 09, 2011	- Packing quantity added
Version 14	Feb 18, 2011	- 0201 PE tape specifications added
Version 13	Sep 15, 2010	- Dimensions of blister tape updated
Version 12	Sep 18, 2009	- PE tape specifications updated
Version 11	Sep 07, 2009	- PE tape specifications added
Version 10	Jun 12, 2009	- Paper tape specifications updated
Version 9	Apr 03, 2009	- Change to dual brand datasheet - Label definition updated - Reflow soldering for Sn/Pb chart updated - Reflow soldering for lead free (Pb-free) chart added - Double wave soldering chart updated - Tests and requirements updated
Version 8	Apr 11, 2006	- Taping quality improved
Version 7	Jul 10, 2003	- Company logo updated - Taping specification updated - Label definition updated