

Cisco UCS 6324 Fabric Interconnect

Cisco Unified Computing System Overview

The Cisco Unified Computing System™ (Cisco UCS®) is a next-generation data center platform that unites computing, networking, storage access, and virtualization resources into a cohesive system designed to reduce total cost of ownership (TCO) and increase business agility. The system integrates a low-latency, lossless 10 Gigabit Ethernet unified network fabric with enterprise-class, x86-architecture servers. The system is an integrated, scalable, multichassis platform in which all resources participate in a unified management domain (Figure 1).

The Cisco UCS 6324 Fabric Interconnect extends the Cisco UCS architecture into environments with requirements for smaller domains. Providing the same unified server and networking capabilities as in the full-scale Cisco UCS solution, the Cisco UCS 6324 Fabric Interconnect embeds the connectivity within the Cisco UCS 5108 Blade Server Chassis to provide a smaller domain of up to 20 servers.

Figure 1. The Cisco Unified Computing System Is a Highly Available Cohesive Architecture

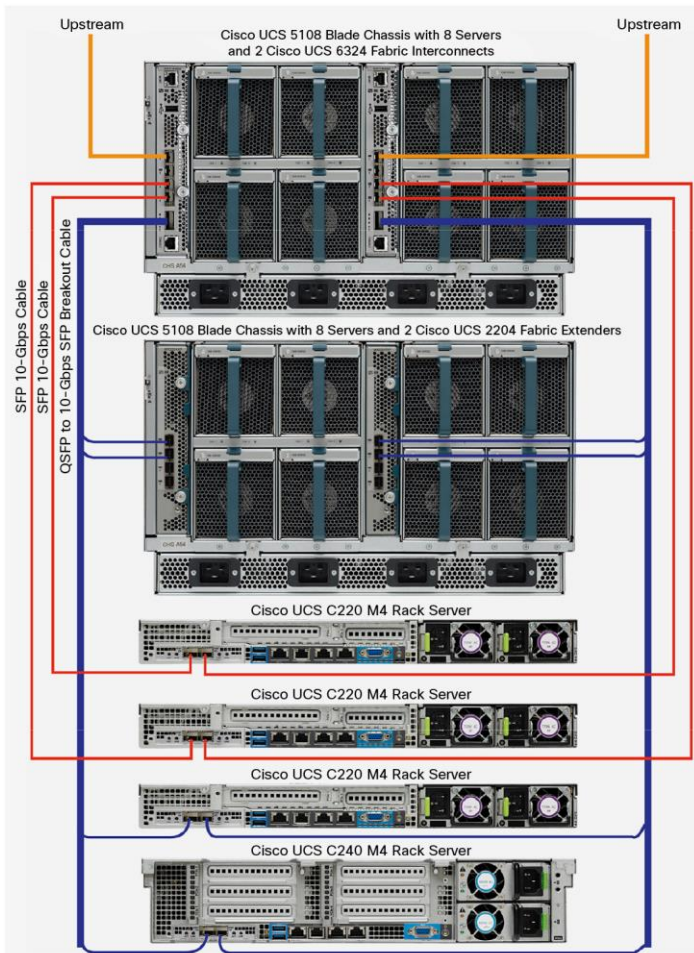

Product Overview

The Cisco UCS 6324 Fabric Interconnect provides the management, LAN, and storage connectivity for the Cisco UCS 5108 Blade Server Chassis and direct-connect rack-mount servers. It provides the same full-featured Cisco UCS management capabilities and XML API as the full-scale Cisco UCS solution in addition to integrating with Cisco UCS Central Software and Cisco UCS Director (Figure 2).

From a networking perspective, the Cisco UCS 6324 Fabric Interconnect uses a cut-through architecture, supporting deterministic, low-latency, line-rate 10 Gigabit Ethernet on all ports, switching capacity of up to 500 Gbps, and 80-Gbps uplink bandwidth for each chassis, independent of packet size and enabled services. Sixteen 10-Gbps links connect to the servers, providing a 20-Gbps link from each Cisco UCS 6324 Fabric Interconnect to each server. The product family supports Cisco® low-latency, lossless 10 Gigabit Ethernet¹ unified network fabric capabilities, which increase the reliability, efficiency, and scalability of Ethernet networks. The fabric interconnect supports multiple traffic classes over a lossless Ethernet fabric from the blade through the fabric interconnect. Significant TCO savings come from a Fibre Channel over Ethernet (FCoE)-optimized server design in which network interface cards (NICs), host bus adapters (HBAs), cables, and switches can be consolidated.

Figure 2. Cisco UCS Management Architecture

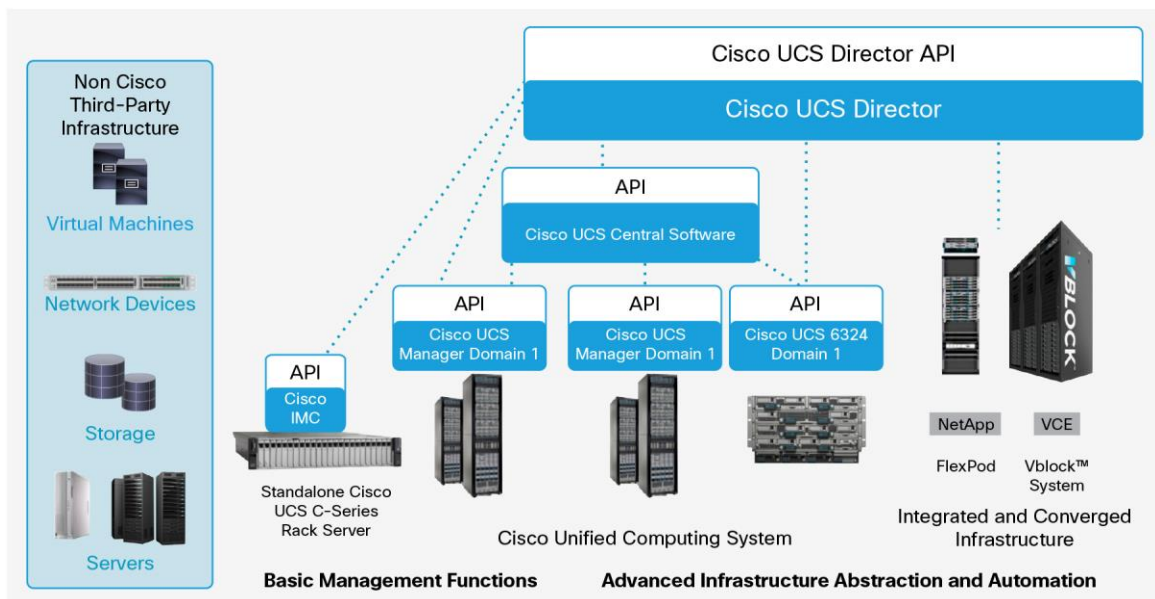

Unified Fabric with FCoE: I/O Consolidation

The Cisco UCS 6324 Fabric Interconnect is built to consolidate LAN and storage traffic onto a single unified fabric, eliminating the capital expenditures (CapEx) and operating expenses (OpEx) associated with multiple parallel networks, different types of adapter cards, switching infrastructure, and cabling within racks. The unified ports allow the fabric interconnect to support direct connections from Cisco UCS to Fibre Channel, FCoE, and Small Computer System Interface over IP (iSCSI) storage devices.

¹ All Cisco UCS 6324 Fabric Interconnect SFP+ ports can alternatively be configured for 1 Gigabit Ethernet.

Cisco UCS Manager

The Cisco UCS 6324 Fabric Interconnect hosts and runs Cisco UCS Manager in a highly available configuration, enabling the fabric interconnects to fully manage all Cisco UCS elements. The Cisco UCS 6324 Fabric Interconnect Fabric Interconnects support out-of-band management through a dedicated 10/100/1000-Mbps Ethernet management port. Cisco UCS Manager typically is deployed in a clustered active-passive configuration on with two UCS 6324 Fabric Interconnects connected through the cluster interconnect built into the chassis.

Optimization for Virtualization

For virtualized environments, the Cisco UCS 6324 Fabric Interconnect supports Cisco virtualization-aware networking and Cisco Data Center Virtual Machine Fabric Extender (VM-FEX) architecture. Cisco Data Center VM-FEX allows the fabric interconnects to provide policy-based virtual machine connectivity, with network properties moving with the virtual machine and a consistent operational model for both physical and virtual environments.

Cisco UCS 6324 Fabric Interconnect

The Cisco UCS 6324 Fabric Interconnect Fabric Interconnect (Figure 3) is a 10 Gigabit Ethernet, FCoE, and Fibre Channel switch offering up to 500-Gbps throughput and up to four unified ports and one scalability port.

Figure 3. Cisco UCS 6324 Fabric Interconnect

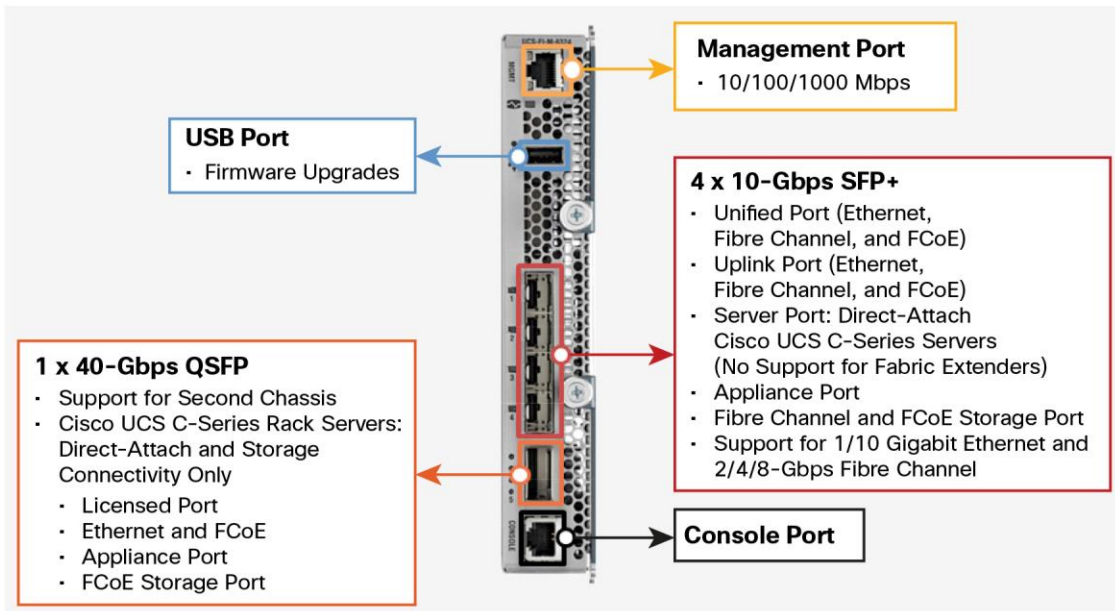

Table 1 summarizes the characteristics of the Cisco UCS 6324 Fabric Interconnect.

Table 1. Characteristics of Cisco UCS 6324 Fabric Interconnect²

Item	Cisco UCS 6324
Description	Fabric interconnect with 4 unified ports and 1 scalability port
Form factor	I/O module for Cisco UCS 5108 chassis
Number of 1 and 10 Gigabit Ethernet, FCoE, or Fibre Channel Enhanced Small Form-Factor Pluggable (SFP+) external ports	4
Number of 40 Gigabit Ethernet or FCoE Enhanced Quad SFP (QSFP) ports	1
Server ports	16 x 10GBASE-KR lanes
Number of rack servers supported³	Single Cisco UCS 5108 Blade Server Chassis: 7 With second Cisco UCS 5108 Blade Server Chassis: 4
Throughput	500 Gbps
Latency	Less than a microsecond
Quality-of-service (QoS) hardware queues	16 (8 each for unicast and multicast)

Features and Benefits

Table 2 summarizes the features and benefits of the Cisco UCS 6324 Fabric Interconnect.

Table 2. Features and Benefits

Feature	Benefit
Management by Cisco UCS Manager	<ul style="list-style-type: none"> Allows all elements connected to the interconnects to participate in a single, highly available management domain
Unified fabric	<ul style="list-style-type: none"> Decreases TCO by reducing the number of NICs, HBAs, switches, and cables needed Transparently encapsulates Fibre Channel packets into Ethernet
Performance	<ul style="list-style-type: none"> Provides high-speed, low-latency connectivity to the chassis
Lossless fabric	<ul style="list-style-type: none"> Provides a reliable, robust foundation for unifying LAN and SAN traffic on a single transport
Priority flow control (PFC)	<ul style="list-style-type: none"> Simplifies management of multiple traffic flows over a single network link Supports different classes of service, helping enable both lossless and classic Ethernet on the same fabric
Cisco Data Center VM-FEX technology	<ul style="list-style-type: none"> Helps enable a consistent operational model for both virtual and physical environments Provides the same level of network visibility for virtualized and nonvirtualized environments Improves diagnostic and troubleshooting capabilities in a virtual environment Simplifies network and security policy enforcement when migrating virtual machines from one host to another
SFP+ ports	<ul style="list-style-type: none"> Increases flexibility with a range of interconnect solutions, including copper Twinax cable for short runs and fiber for long runs Consumes less power per port than traditional solutions Helps enable cost-effective connections on fabric extenders with Cisco Fabric Extender Transceiver (FET) optics
SFP-compatible ports	<ul style="list-style-type: none"> Allows all fixed SFP+ ports to be configured to operate in 1 Gigabit Ethernet mode with the transceiver options specified for use with the SFP-compatible ports listed in Table 3

² The Cisco UCS 6324 Fabric Interconnect requires Cisco UCS Manager Release 3.0 or later operating software.

³ See the Cisco UCS Mini blade server chassis specifications sheet for all the permutations.

Product Specifications

Unified Port Transceivers

The Cisco UCS 6324 Fabric Interconnect supports a wide variety of 10 Gigabit Ethernet connectivity options using Cisco 10GBASE SFP+ modules. In addition, the four SFP+ uplink ports support 1 Gigabit Ethernet connectivity options using 1GBASE SFP modules. Alternatively, 2/4/8-Gbps Fibre Channel SFP+ interfaces are supported.

Table 3 lists the supported transceiver options.

Table 3. Cisco UCS 6324 Fabric Interconnect Transceiver Support Matrix

Cisco SFP	Description
Cisco DS-SFP-FC4G-LW	4-Gbps Fibre Channel LW SFP, LC (10-km reach)
Cisco DS-SFP-FC4G-SW	4-Gbps Fibre Channel SW SFP, LC
Cisco DS-SFP-FC8G-LW	8-Gbps Fibre Channel LW SFP+, LC
Cisco DS-SFP-FC8G-SW	8-Gbps Fibre Channel SW SFP+, LC
Cisco GLC-T	1000BASE-T SFP
Cisco GLC-LH-SM	GE SFP, LC connector LX/LH transceiver (SMF) (for SFP-compatible ports only, as defined in Table 2)
Cisco GLC-SX-MM	GE SFP, LC connector SX transceiver (MMF) (for SFP-compatible ports only, as defined in Table 2)
Cisco GLC-T	1000BASE-T SFP (for SFP-compatible ports only, as defined in Table 2)
Cisco SFP-10G-AOC10M	10GBASE active optical SFP+ cable, 10m
Cisco SFP-10G-AOC1M	10GBASE active optical SFP+ cable, 1m
Cisco SFP-10G-AOC3M	10GBASE active optical SFP+ cable, 3m
Cisco SFP-10G-AOC5M	10GBASE active optical SFP+ cable, 5m
Cisco SFP-10G-AOC7M	10GBASE active optical SFP+ cable, 7m
Cisco SFP-10G-LR	10GBASE-LR SFP module
Cisco SFP-10G-LR-X	10GBASE-LR SFP module for extended temperature range
Cisco SFP-10G-SR	10GBASE-SR SFP+ module (multimode fiber [MMF])
Cisco SFP-10G-SR-X	10GBASE-SR SFP+ transceiver module for MMF, 850-nm wavelength, LC duplex connector, extended temperature range
Cisco SFP-H10GB-ACU10M	10GBASE-CU SFP+ cable, 10m (Twinax cable)
Cisco SFP-H10GB-ACU7M	10GBASE-CU SFP+ cable, 7m (Twinax cable)
Cisco SFP-H10GB-CU1M	10GBASE-CU SFP+ cable, 1m (Twinax cable)
Cisco SFP-H10GB-CU2M	10GBASE-CU SFP+ cable, 2m (Twinax cable)
Cisco SFP-H10GB-CU3M	10GBASE-CU SFP+ cable, 3m (Twinax cable)
Cisco SFP-H10GB-CU5M	10GBASE-CU SFP+ cable, 5m (Twinax cable)

Scalability Port Transceivers

The Cisco UCS 6324 Fabric Interconnect supports a QSFP+ port that provides connectivity for up to 4 Cisco UCS rack servers. Table 4 lists the transceiver options support by the scalability port.

Table 4. QSFP+ Transceiver Support Matrix

QSFP-4SFP10G-CU1M	40GBASE-CR4 QSFP+ to 4 10GBASE-CU SFP+ direct-attach breakout cable assemblies, 1m passive
QSFP-4SFP10G-CU3M	40GBASE-CR4 QSFP+ to 4 10GBASE-CU SFP+ direct-attach breakout cable assemblies, 3m passive
QSFP-4SFP10G-CU5M	40GBASE-CR4 QSFP+ to 4 10GBASE-CU SFP+ direct-attach breakout cable assemblies, 5m passive
QSFP-40G-SR4	40GBASE-SR4, 4 lanes, 850 nm MMF QSFP transceiver nodule with MPO connector

QSFP-4x10G-AC10M	40GBASE-CR4 QSFP+ to 4 10GBASE-CU SFP+ direct-attach breakout cable assemblies, 10m active
QSFP-4x10G-AC7M	40GBASE-CR4 QSFP+ to 4 10GBASE-CU SFP+ direct-attach breakout cable assemblies, 7m active
QSFP-4X10G-AOC10M	40GBASE active optical QSFP to 4SFP breakout cable, 10m

Cabling

Table 5 provides cabling specifications for the Cisco UCS 6324 Fabric Interconnect.

Table 5. Cabling Specifications

Connector (Media)	Cable	Distance	Power (Each Side)	Transceiver Latency (Link)	Standard
SFP+ copper (CU)	Twinax	1, 3, 5, 7, and 10m	Approximately 0.1 watt (W)	Approximately 0.1 microsecond	SFF 8431
SFP+ short reach (SR) and MMF	MM OM2 MM OM3 MM OM4	82 and 300m	1W	Approximately 0 microseconds	IEEE 802.3ae
QSFP+ copper (CU)	Twinax	1, 3, 5, 7, and 10m	1.5W	Approximately 0.1 microsecond	SFF 8635

Performance

- Cisco UCS 6324 Fabric Interconnect: Layer 2 hardware forwarding at 500 Gbps or 375 million packets per second (mpps)
- MAC address table entries: 20,000
- Low-latency cut-through design: Provides predictable, consistent traffic latency regardless of packet size, traffic pattern, or enabled features

Layer 2

- Layer 2 interconnect ports and VLAN trunks
- IEEE 802.1Q VLAN encapsulation
- Support for up to 512 VLANs and 32 virtual SANs (VSANs) per interconnect
- Internet Group Management Protocol (IGMP) Versions 1, 2, and 3 snooping
- Link Aggregation Control Protocol (LACP): IEEE 802.3ad
- Advanced EtherChannel hashing based on Layer 2, 3, and 4 information
- Jumbo frames on all ports (up to 9216 bytes)
- Pause frames (IEEE 802.3x)

QoS

- Layer 2 IEEE 802.1p (class of service [CoS])
- CoS trust
- CoS-based egress queuing
- Egress port-based scheduling: Deficit Weighted Round-Robin (DWRR)
- 16 hardware queues (8 each for unicast and multicast)

High Availability

- Two Cisco UCS 6324 Fabric Interconnect Fabric Interconnects can be clustered together within the chassis to provide a highly available interconnect system
- Firmware upgrades can be performed on each fabric interconnect independently, allowing server connectivity to be maintained while firmware upgrades are completed

Management

- Interconnect management using redundant 10/100/1000-Mbps management or console ports
- All management provided through Cisco UCS Manager; please refer to the Cisco UCS Manager data sheet for more information about management interfaces

Data Center Bridging 10 Gigabit Ethernet Unified Network Fabric

- IEEE 802.1Qpfc (per-priority pause frame support)
- Data Center Bridging Exchange (DCBX) Protocol
- IEEE 802.1Qaz: Bandwidth management

Unified Ports

- All 4 SFP+ ports configurable as 1/10 Gigabit Ethernet or 2/4/8-Gbps Fibre Channel

Industry Standards

- IEEE 802.1p: CoS prioritization
- IEEE 802.1Q: VLAN tagging
- IEEE 802.3: Ethernet
- IEEE 802.3ad: LACP
- IEEE 802.3ae: 10 Gigabit Ethernet
- IEEE 802.1AB LLDP
- SFP+ support
- RMON

Physical Specifications

SFP+ Optics

Cisco UCS products support 10 Gigabit Ethernet SFP+ copper Twinax cables for short distances and SFP+ optics for longer distances. SFP+ has several advantages compared to other 10 Gigabit Ethernet connectivity options:

- Small 10 Gigabit Ethernet form factor
- Optical interoperability with XENPAK, X2, and 10 Gigabit Small Form-Factor Pluggable (XFP) interface types
- Low power consumption
- Hot-swappable device

Cisco UCS 6324 Fabric Interconnect Physical and Environmental Specifications

Table 6 summarizes the physical and environmental specifications for the Cisco UCS 6324 Fabric Interconnect.

Table 6. Physical and Environmental Specifications

Property	Cisco UCS 6324
Physical (height x width x depth)	7.64 x 1.36 x 7.2 in. (194 x 34.5 x 183 mm)
Ambient Operating temperature	32 to 95°F (0 to 35°C)
Nonoperating temperature	-40 to 158°F (-40 to 70°C)
Humidity	5 to 95% (noncondensing)
Altitude	0 to 10,000 ft (0 to 300m)
Weight	2.5 lb (1.134 kg)

Regulatory Standards Compliance: Safety and EMC

Table 7 summarizes Cisco UCS 6324 Fabric Interconnect regulatory compliance.

Table 7. Regulatory Standards Compliance

Specification	Description
Regulatory compliance	Products complies with CE Markings according to directives 2004/108/EC and 2006/95/EC
Safety	<ul style="list-style-type: none">• UL 60950-1• CAN/CSA-C22.2 No. 60950-1• EN 60950-1• IEC 60950-1• AS/NZS 60950-1• GB4943
EMC: Emissions	<ul style="list-style-type: none">• 47CFR Part 15 (CFR 47) Class A• AS/NZS CISPR22 Class A• CISPR22 Class A• EN55022 Class A• ICES003 Class A• VCCI Class A• EN61000-3-2• EN61000-3-3• KN22 Class A• CNS13438 Class A
EMC: Immunity	<ul style="list-style-type: none">• EN50082-1• EN61000-6-1• EN55024• CISPR24• EN300386• KN 61000-4 series
RoHS	The product is RoHS 6-compliant

Warranty Information

Warranty information is provided at Cisco.com on the [Product Warranties](#) page.

Cisco Unified Computing Services

Using a unified view of data center resources, Cisco and our industry-leading partners deliver services that accelerate your transition to a unified computing environment. Cisco Unified Computing Services helps you quickly deploy your data center resources and optimize ongoing operations to better meet your business needs. For more information about these and other Cisco Data Center Services, visit <http://www.cisco.com/go/dcservices>.

Why Cisco?

Cisco has significant experience in listening to customer requirements and providing solid technology innovation for the enterprise data center. Cisco delivers standards-based solutions backed by a broad partner ecosystem of industry leaders to provide end-to-end customer solutions. Unified computing elevates the traditional product classification of network, server, storage, operating systems, and applications to a vision that encompasses the whole data center. Cisco, as one of the largest technology providers in the world, has the resources, expertise, and customer focus to deliver on this vision.

Cisco Capital

Financing to Help You Achieve Your Objectives

Cisco Capital can help you acquire the technology you need to achieve your objectives and stay competitive. We can help you reduce CapEx. Accelerate your growth. Optimize your investment dollars and ROI. Cisco Capital financing gives you flexibility in acquiring hardware, software, services, and complementary third-party equipment. And there's just one predictable payment. Cisco Capital is available in more than 100 countries. [Learn more.](#)

For More Information

For more information about the Cisco UCS 6324 Fabric Interconnect, visit <http://www.cisco.com/en/US/products/ps10276/index.html> or contact your local account representative.



Americas Headquarters
Cisco Systems, Inc.
San Jose, CA

Asia Pacific Headquarters
Cisco Systems (USA) Pte. Ltd.
Singapore

Europe Headquarters
Cisco Systems International BV Amsterdam,
The Netherlands

Cisco has more than 200 offices worldwide. Addresses, phone numbers, and fax numbers are listed on the Cisco Website at www.cisco.com/go/offices.

Cisco and the Cisco logo are trademarks or registered trademarks of Cisco and/or its affiliates in the U.S. and other countries. To view a list of Cisco trademarks, go to this URL: www.cisco.com/go/trademarks. Third party trademarks mentioned are the property of their respective owners. The use of the word partner does not imply a partnership relationship between Cisco and any other company. (1110R)