



Cisco TelePresence SpeakerTrack 60

INSTALLATION GUIDE



The SpeakerTrack 60 uses a unique dual-camera technique to quickly view a close-up of the active speaker in the meeting room.

Contents

Installation	3
Safety instructions.....	4
Room guidelines	5
Mounting the unit above the monitor.....	6
Mounting in a recess above the monitor	7
Mounting the unit below the monitor.....	8
Mounting in a recess below the monitor	9
Mount the wall bracket.....	10
Mount the base unit	11
Mount the cables	12
Mount the assembly to the wall.....	13
Mount the interface plate	14
Connect the camera cables.....	15
Fasten the cameras	16
Finish up.....	17
User documentation and support.....	18

Installation

We invite you to explore the *Project Workplace* guide to inspire you on room design and room setup. Go to: www.cisco.com/go/projectworkplace

Main box contents

- A. 1 × Cover plate
- B. 1 × Microphone panel with four built-in microphones
- C. 2 × Precision 60 Camera
- D. 1 × Base unit, with connectors
 - 1 × Accessories box
 - 1 × Installation Guide

Accessories

- E. 2 × Camera interface plate
- F. 1 × Wall bracket
- G. 1 × DC Power cable w/ barrel plug, 20 cm / 7.87 in
- H. 1 × DC Power cable w/ barrel plug, 45 cm / 17.72 in
- I. 1 × Ethernet cable, 20 cm / 7.87 in
- J. 1 × Ethernet cable, 35 cm / 13.78 in
- K. 1 × Power adapter and power cable
- L. 1 × Gloves
- M. 1 × Torx Key (T20)
- N. 1 × Allen Key
- O. 2 × Thumb nut, M4
- P. 4 × Pan headed screw, M4 16 mm
- Q. 2 × 1/4" UNC screw
- R. 1 × Template for attaching the wall bracket (not shown)

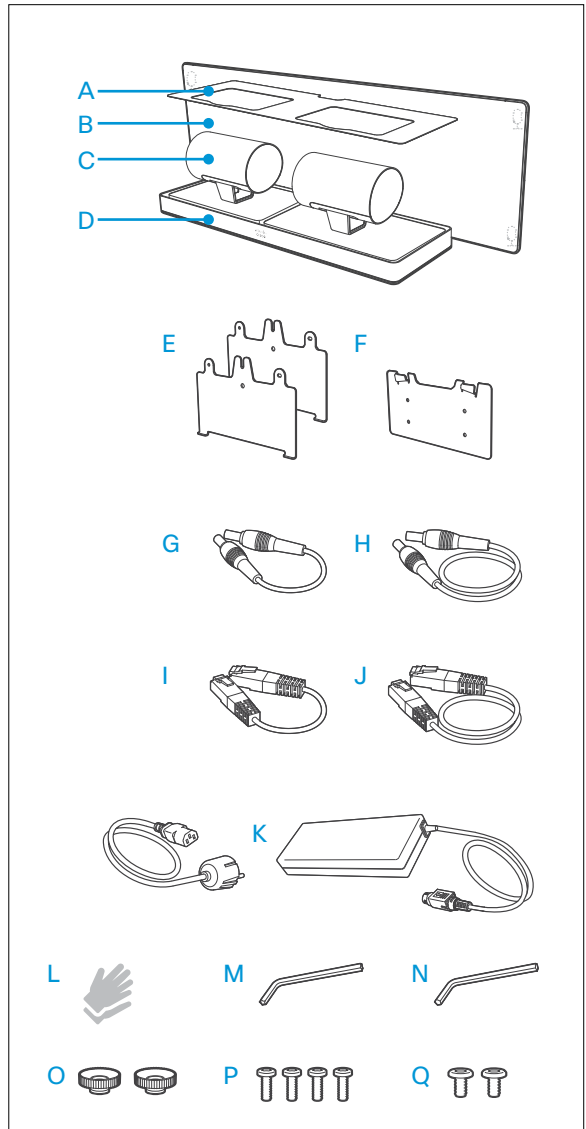

Safety instructions

WARNING: Use Ethernet cable only when connecting to the Ethernet port on the camera. Do not connect a serial VISCA cable to the Ethernet port on the camera, as this will cause severe damage to the camera.

NOTE: It is of great importance that the wall mount unit is safely installed, that the wall is able to support the product and that the screws or mounting means used are suitable for the wall and the weight of the product.

NOTE: According to the relevant international safety standard for IT products the wall is required to support four times the actual load, which implies that the SpeakerTrack 60 must be mounted to a wall which supports at least: $4 \times 11.25 \text{ kg} = 45 \text{ kg}$ ($4 \times 24.8 \text{ lbs} = 99.2 \text{ lbs}$).

NOTE: This type of equipment is to be installed by the submitter's/dealer's qualified installer. The installer is responsible for obtaining safety inspection of the structural integrity of the installation by the local authority/inspection department.

NOTE: Note that the surface is hot when the camera is in operation.

Room guidelines

The participants should be seated within the horizontal field of view (HFOV) and within the maximum microphone range. For optimal audio tracking the SpeakerTrack should be mounted at some distance from the side walls. In acoustically dampened rooms, the SpeakerTrack 60 can be used at the full effective range. In less dampened rooms, the performance may be decreased.

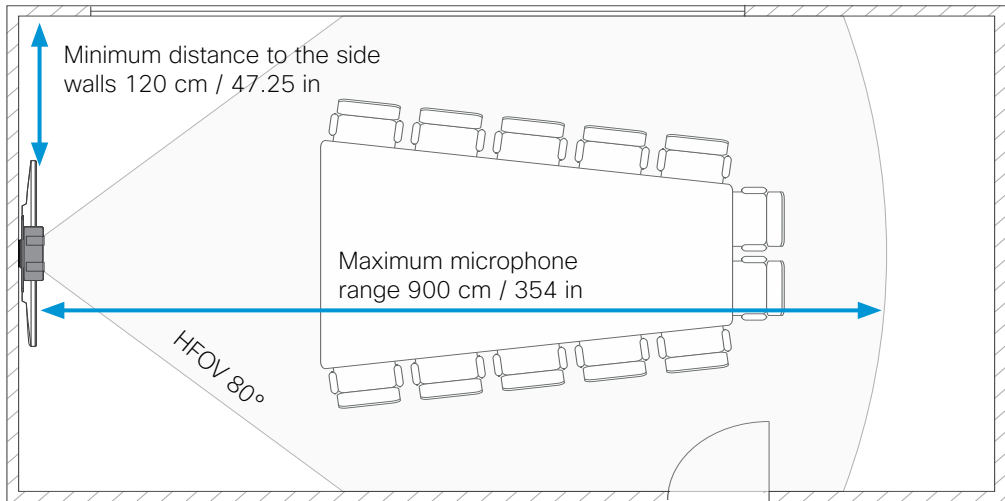

Top view of a room with SpeakerTrack 60.

Mounting the unit above the monitor

Having eye contact with remote participants is essential for a good user experience, and therefore you should consider if SpeakerTrack 60 should be mounted above or below the monitor.

NOTE: Obstacles placed in front of the microphone panel, or in the sight line of the microphones, will cause severe loss in the speaker track performance.

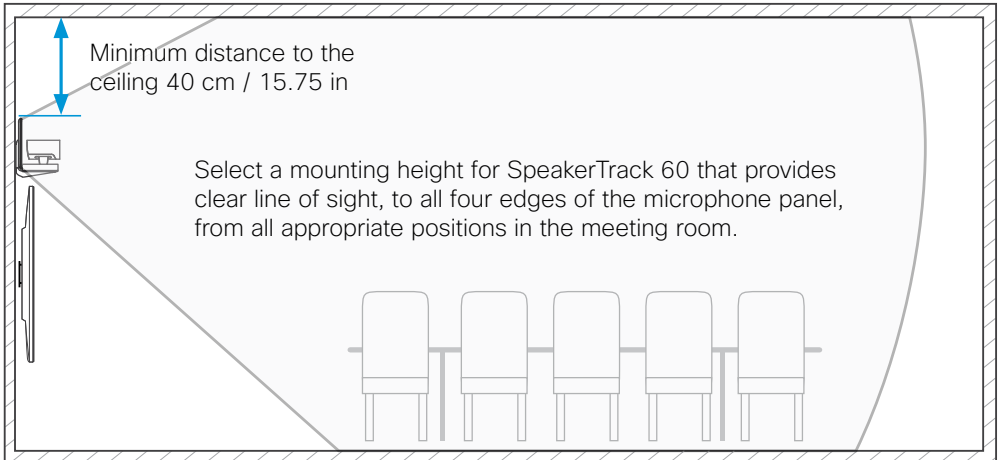

Side view of a room with SpeakerTrack 60 mounted above the monitor. For optimal audio tracking the SpeakerTrack should be mounted at some distance to the ceiling.

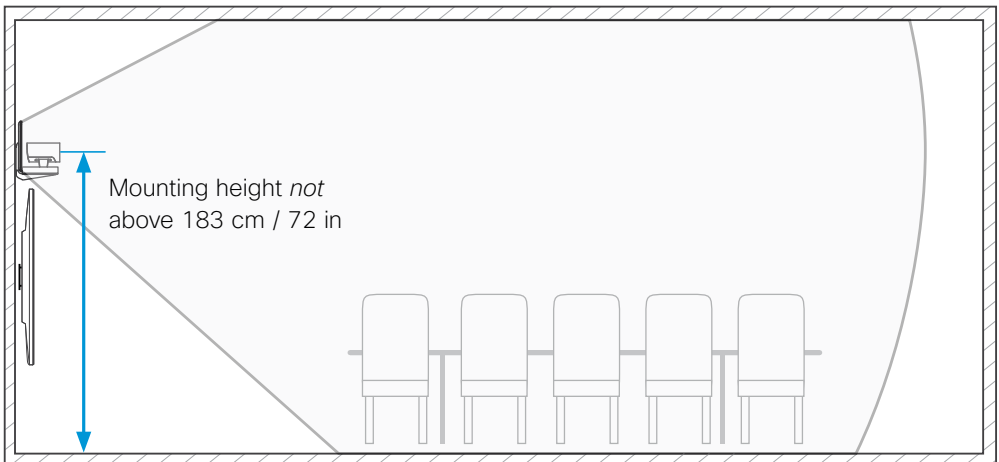

Side view of a room with SpeakerTrack 60 mounted above the monitor. The recommended mounting height of SpeakerTrack (measured to the center of the camera lens) is not to be higher than 183 cm / 72 in above the floor.

Mounting in a recess above the monitor

SpeakerTrack 60 is designed to be wall mounted. If mounted in a recess, the sound from any participant in the room must reach at least three of the four microphones on the microphone panel. To obtain this, the recess should be constructed with sloping walls.

CAD drawings with details and dimensions: <http://www.cisco.com/go/telepresence/docs> and navigate to: Collaboration Endpoints > Collaboration Peripherals > TelePresence Peripherals > TelePresence SpeakerTrack 60 > Technical References

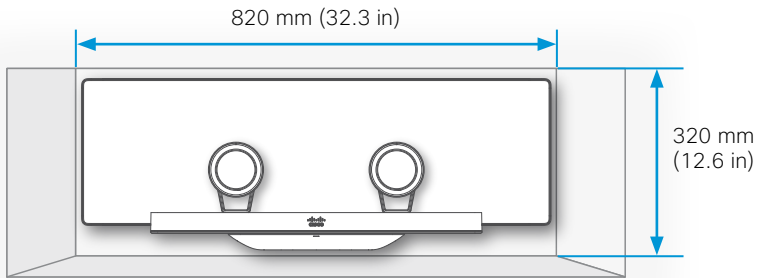

- The bottom wall of the recess is sloped 17°
- The side walls of the recess are sloped 45°
- The maximum depth of the recess is 217.6 mm (8.56 in). If less depth the camera will protrude from the wall. Follow local building regulations and accessibility requirements.

Mounting the unit below the monitor

Having eye contact with remote participants is essential for a good user experience, and therefore you should consider if SpeakerTrack 60 should be mounted above or below the monitor.

NOTE: Obstacles placed in front of the microphone panel, or in the sight line of the microphones, will cause severe loss in the speaker track performance.

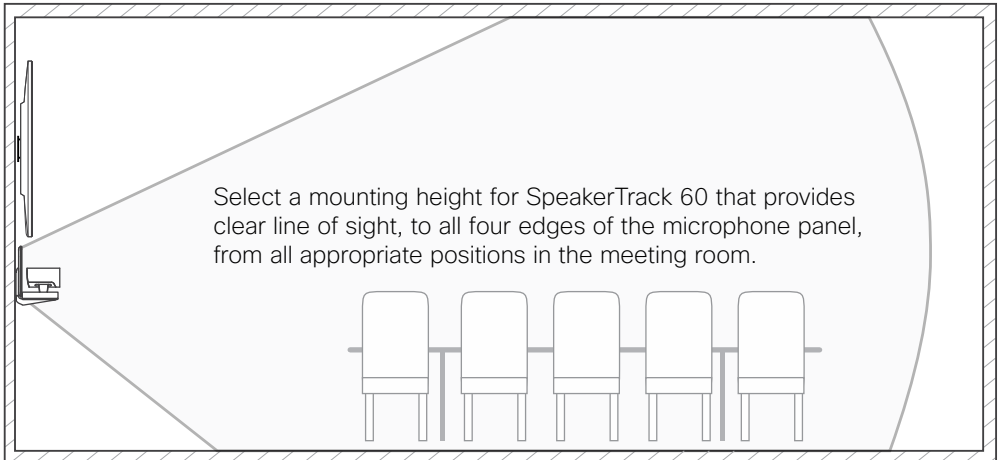

Side view of a room with SpeakerTrack 60 mounted below the monitor. For large monitors (70" and above), we recommend mounting the SpeakerTrack below the monitor.

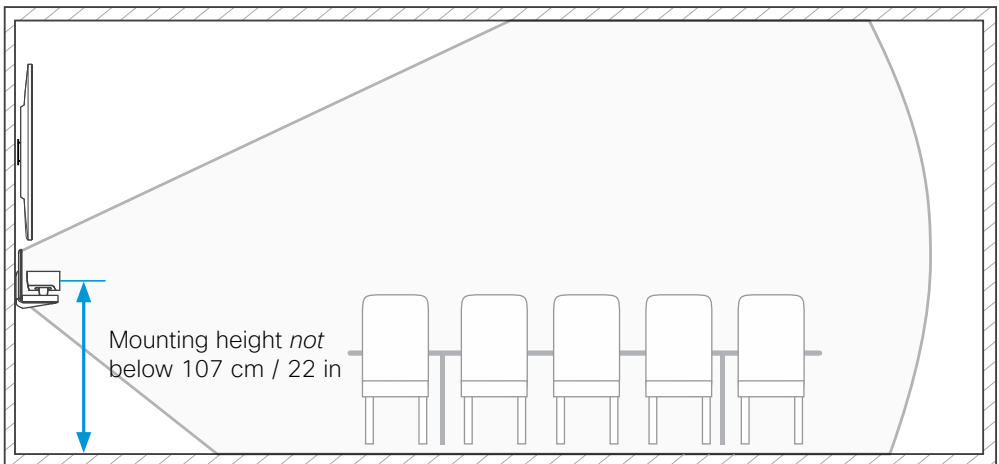

Side view of a room with SpeakerTrack 60 mounted below the monitor. The recommended mounting height of SpeakerTrack (measured to the center of the camera lens) is not to be lower than 107 cm / 42 in above the floor.

Mounting in a recess below the monitor

SpeakerTrack 60 is designed to be wall mounted. If mounted in a recess/box, the sound from any participant in the room must reach at least three of the four microphones on the microphone panel. To obtain this the recess/box must be constructed with inclined walls.

CAD drawings with details and dimensions: <http://www.cisco.com/go/telepresence/docs> and navigate to: Collaboration Endpoints > Collaboration Peripherals > TelePresence Peripherals > TelePresence SpeakerTrack 60 > Technical References

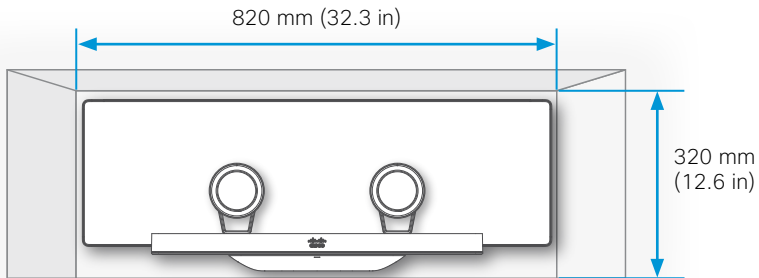

- The upper wall of the recess is sloped 17°
- The side walls of the recess are sloped 45°
- The maximum depth of the recess is 217.6 mm (8.56 in). If less depth the camera will protrude from the wall. Follow local building regulations and accessibility requirements.

Mount the wall bracket

Read the room guidelines, mounting guidelines and safety instructions before you start mounting the wall bracket (F).

Before you proceed with the installation:

Use the *Template for attaching the wall bracket* (R), found with the accessories, and follow the instructions on the template when mounting the wall bracket.

Template for attaching wall bracket for SpeakerTrack 60
Gabarit de fixation du support mural pour SpeakerTrack 60

Find the center point of the monitor and the top center point of the SpeakerTrack 60 rear panel.
Localisez le centre du moniteur et le centre supérieur du SpeakerTrack 60.

Check that the unit is level.
Vérifiez que l'appareil est à niveau.

SpeakerTrack 60 rear panel
SpeakerTrack 60 panneau arrière

The monitor center point

Use the template on the other side of this sheet when drilling holes for the wall bracket. Screw dimension M5.
Utilisez le modèle au verso de cette page pour le perçage des trous de la fixation murale. Vis dimension M5.

Template for drilling holes (found overleaf)
Modèle pour les trous de forage (au verso)

Select the type of attachment for the wall bracket on the basis of the type of material the wall is made of (wood, concrete, gypsum).
Sélectionnez le type de fixation du support mural en fonction du type de matériau du mur (bois, ciment, gypse).

Wall bracket
Support mural

78-100272-01A0 | FEBRUARY 2014
Copyright © 2014 Cisco Systems, Inc. All rights reserved.

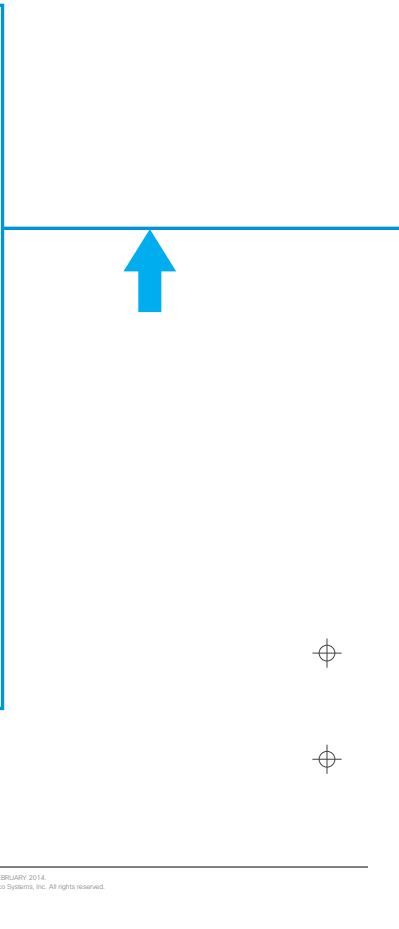

78-100272-01A0 | FEBRUARY 2014
Copyright © 2014 Cisco Systems, Inc. All rights reserved.

Mount the base unit

Place the microphone panel (B) on a clean and stable surface (for example a table) with the microphone cables headed up and the textile headed down.

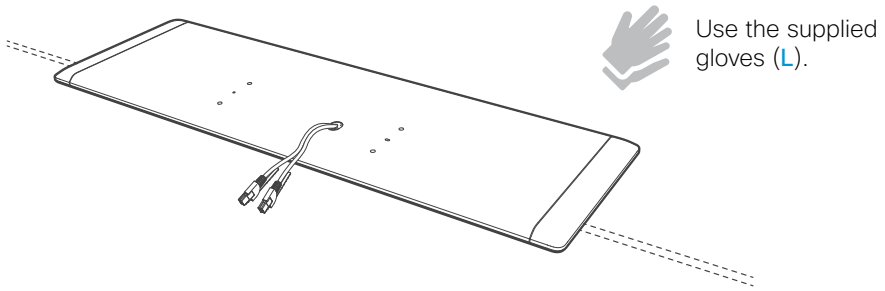

Remove the cover plate (A) from the base unit before this operation. Hold the base unit (D) as illustrated and slide in place. Make sure the guide-pins positions correctly.

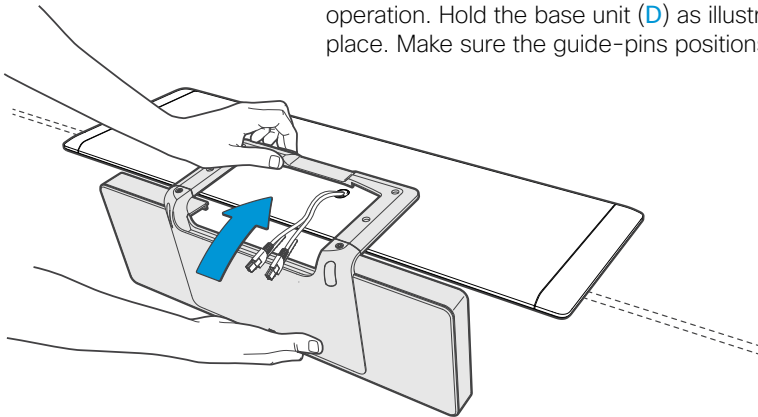

Use the four pan headed screws (P) when fastening the base unit. Use the Torx Key (M) and tighten the screws.

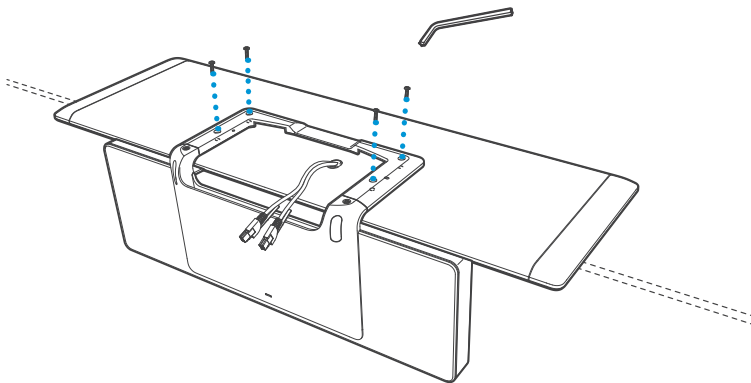

Mount the cables

Connect the cables to the connector panel on the base unit:

1. Find the Ethernet cables (I, J) and the power cables (G, H) in the accessories box. Connect the short cables to the connectors marked R (R) and the long cables to the connectors marked L (L). Lead them through the open slot to make them available for camera mounting.
2. Connect the microphone cables coming from the microphone panel.
3. Find the power adapter and the power cable (K) in the accessories box. Connect the power cable to the base unit.
4. Connect an Ethernet cable (not included) to the Ethernet port on the base unit. Connect the other end directly to the codec. If you do not have any free Ethernet port on the codec (typically if a Touch device is connected) you will need a network switch. Connect the switch to the Ethernet port on the codec, and connect the Touch device and SpeakerTrack 60 to the switch. We recommend using a Cisco switch.

- 1 Connect the short Ethernet and power cables to the right camera, and the long Ethernet and power cables to the left camera.

- 2 Connect the microphone cables that comes from the microphone panel.

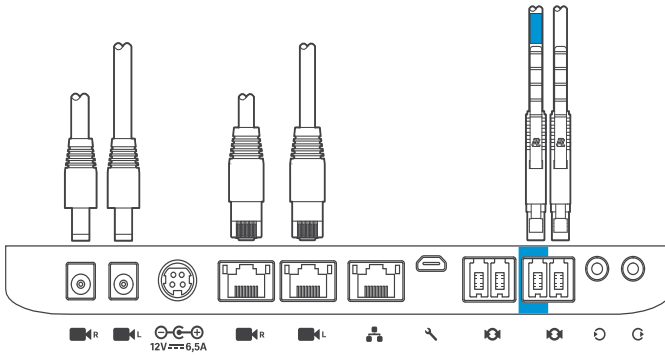

- 3 Connect the power cable.

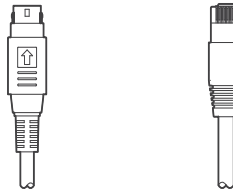

- 4 Connect the Ethernet cable (not included) directly to the codec (Eth2/Eth3).

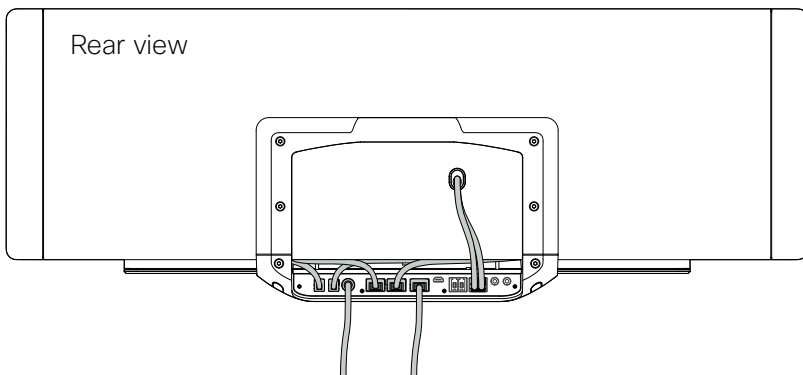

Mount the assembly to the wall

Hold and lift the unit as illustrated. Carefully place the unit onto the wall bracket.

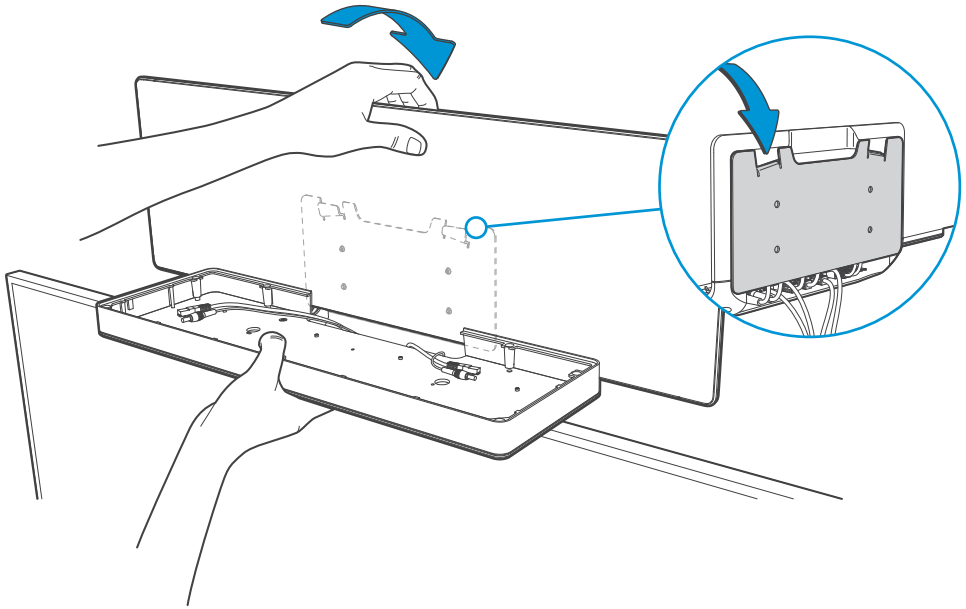

Check that the unit is level. If not, you can adjust the unit sideways.

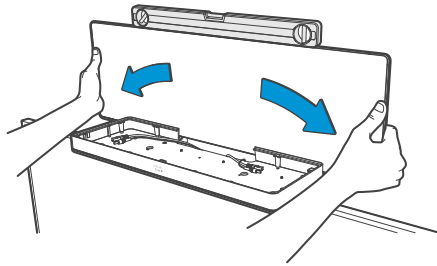

Mount the interface plate

Place the camera (C) on a stable surface as illustrated. Use the 1/4" UNC screw (Q) and Allen Key (N) and mount the camera interface plate (E) to the camera.

Repeat these steps for the second camera (C).

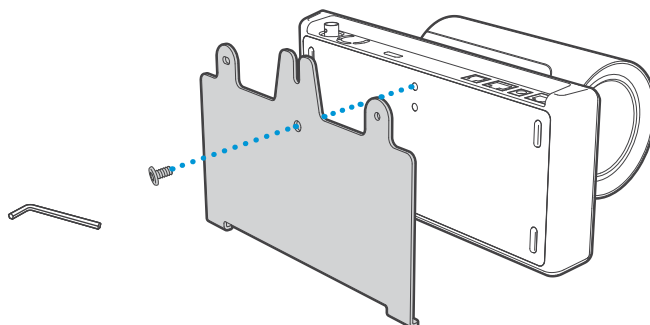

Connect the camera cables

It can be a bit cramped when you connect and secure the cameras, so you'll probably want to inspect the camera connector panel to know where the HDMI, Ethernet and power are located.



Connect one HDMI cable to each camera. The HDMI cables for the two cameras are going to the codec.



The Ethernet and power cables are coming from the base unit. The short cables goes to the right camera and the longer cables to the left camera.

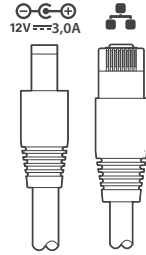

Start with the camera to the right and hold the camera as illustrated. Make sure the short cables (Ethernet and power) are available for this camera and connect the cables. Then connect the HDMI cable coming from the codec. Guide the camera into position.

Proceed with the camera to the left and hold the camera the same way as you did with the first camera. Connect the long cables (Ethernet and power) to the left camera. Connect the HDMI cable coming from the codec. Guide the camera into position.

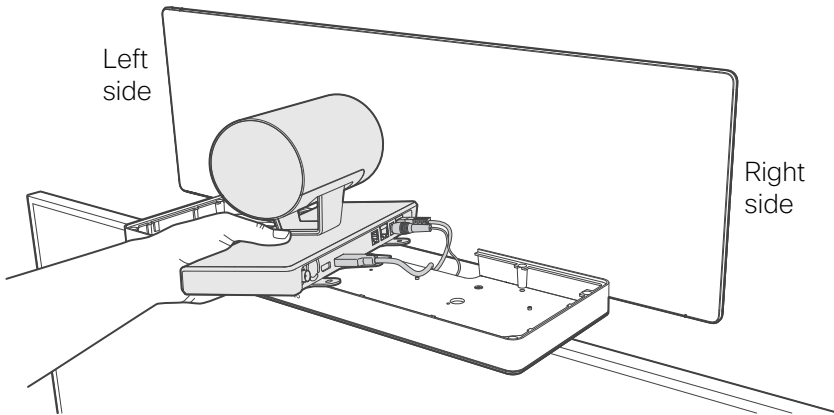

Fasten the cameras

Make sure the pins on the base plate fits the holes in the camera interface plate.

Use the thumb nut (O) to attach the camera to the base. Repeat this step for the second camera.

Make sure the pins on the base plate fits the holes in the camera interface plate.

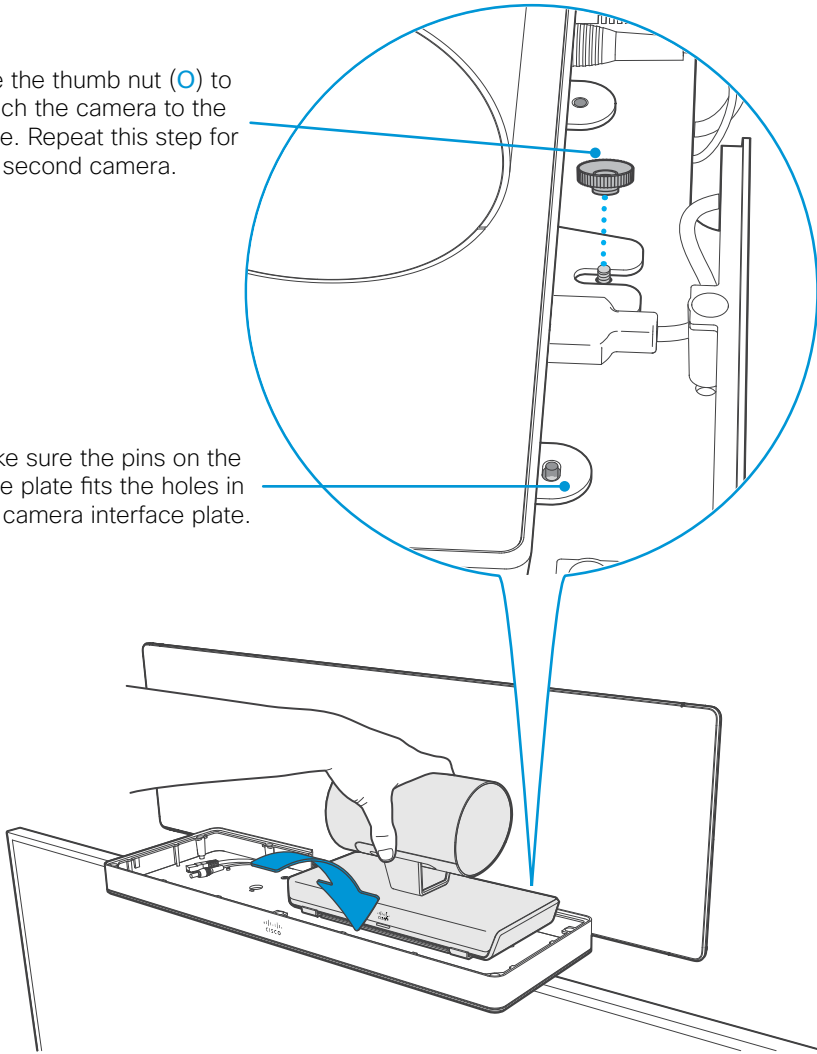

Finish up

- Move the two cameras into standby position as illustrated and carefully slide the cover plate (A) on place.
- Use a cable management for a good aesthetic appearance.
- Connect the Ethernet and HDMI cables to the codec, see the codec documentation for further information.
- Connect the power cable to the power mains.

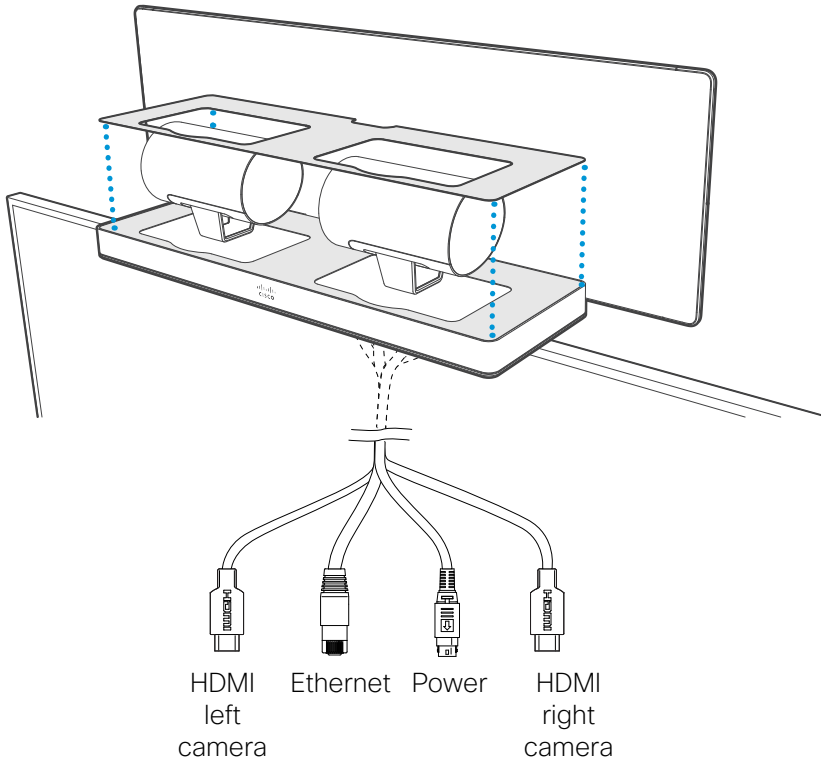

User documentation and support

User documentation for TelePresence SpeakerTrack 60:

<http://www.cisco.com/c/en/us/support/collaboration-endpoints/telepresence-speaker-track-60/tsd-products-support-series-home.html>

User documentation for the TelePresence product range:

<http://www.cisco.com/go/telepresence/docs>

Navigate to: Collaboration Endpoints > Collaboration Peripherals > TelePresence Peripherals > TelePresence SpeakerTrack 60

For support, go to: <http://www.cisco.com/support>



Find an overview of the Cisco offices on our web site.

<http://www.cisco.com/go/offices>

Cisco and the Cisco logo are trademarks or registered trademarks of Cisco and/or its affiliates in the U.S. and other countries. To view a list of Cisco trademarks, go to this URL: www.cisco.com/go/trademarks. Third-party trademarks mentioned are the property of their respective owners. The use of the word partner does not imply a partnership relationship between Cisco and any other company. (1110R)