



Headsets

- [Important Headset Safety Information, on page 1](#)
- [Cisco Headset 500 Series, on page 1](#)
- [Cisco Headset 700 Series, on page 12](#)
- [Third Party Headsets, on page 15](#)
- [Cisco Headset Configuration on Cisco Unified Communications Manager, on page 18](#)
- [Connect a Headset to Your Phone, on page 26](#)
- [Postpone a Phone Upgrade, on page 29](#)
- [Cisco Headset Customization, on page 29](#)
- [Configure a Headset on the Phone, on page 32](#)
- [Make a Call with a Standard Headset, on page 35](#)
- [Audio Path Selection, on page 35](#)
- [Swap Headsets While on a Call, on page 35](#)
- [Troubleshoot Your Cisco Headset, on page 36](#)

Important Headset Safety Information



High Sound Pressure—Avoid listening to high volume levels for long periods to prevent possible hearing damage.

When you plug in your headset, lower the volume of the headset speaker before you put the headset on. If you remember to lower the volume before you take the headset off, the volume will start lower when you plug in your headset again.

Be aware of your surroundings. When you use your headset, it may block out important external sounds, particularly in emergencies or in noisy environments. Don't use the headset while driving. Don't leave your headset or headset cables in an area where people or pets can trip over them. Always supervise children who are near your headset or headset cables.

Cisco Headset 500 Series

The following Cisco headsets are available:

- Cisco Headset 521—A headset with a single earpiece that comes with an inline USB controller.

- Cisco Headset 522—A headset with a dual earpiece that comes with an inline USB controller.
- Cisco Headset 531—A headset with a single earpiece that can be used as either a standard headset or a USB headset with the USB adapter.
- Cisco Headset 532—A standard headset with a dual earpiece that can be used as either a standard headset or a USB headset with the USB adapter.
- Cisco Headset 561—A wireless headset with a single earpiece that comes with a base.
- Cisco Headset 562—A wireless headset with a dual earpiece that comes with a base.

Cisco Headset 521 and 522

The Cisco Headset 521 and 522 are two wired headsets that have been developed for use on Cisco IP Phones and devices. The Cisco Headset 521 features a single earpiece for extended wear and comfort. The Cisco Headset 522 features two earpieces for use in a noisy workplace.

Both headsets feature a 3.5-mm connector for use on laptops and mobile devices. An inline USB controller is also available for use on the Cisco IP Phone 8851, 8851NR, 8861, 8865, and 8865NR. The controller is an easy way answer your calls, and to access basic phone features such as hold and resume, mute, and volume control.

Phone Firmware Release 12.1(1) and later is required for these headsets to function properly.

Figure 1: Cisco Headset 521



Figure 2: Cisco Headset 522



Cisco Headset 531 and 532

The Cisco Headset 531 and 532 can be used as standard headsets on the phones. You plug the headset into the headset port using the RJ connector.

The Cisco Headset USB Adapter is also available for use on the Cisco IP Phone 8851, 8851NR, 8861, 8865, and 8865NR. The adapter converts the Cisco Headset 531 and 532 into a USB headset, and it gives you a few extra features. It provides a convenient way to handle calls, to test your microphone, and to customize your bass and treble, gain, and sidetone settings.

Phone Firmware Release 12.1(1) and later is required for the headsets to function properly.

Figure 3: Cisco Headset 531



Figure 4: Cisco Headset 532



Cisco Headset 561 and 562

Cisco Headset 561 and 562 are two wireless headsets that have been developed for use in today's office. The Cisco Headset 561 features a single earpiece for extended wear and comfort. Cisco Headset 562 features two earpieces for use in a noisy workplace.

Both headsets come with either the Standard base or the Multibase for charging your headset, and for monitoring the headset power level with the LED display. Both bases also displays your call status, such as incoming call, active call, and calls on mute. If your headset is upgrading the firmware, then the LEDs show the upgrade progress.

The base connects to the phone using either a USB connector or a Y cable depending upon your phone model and your personal preference. The Y cable plugs into the AUX and headset ports of the phone.

An AC plug is included for connecting the base to a power outlet. You have to install the power clip for your region before you can plug in the power adapter.

Occasionally a tone is played over your Cisco Headset 561 or 562. Some of these tones alert you when you perform an action, such as pressing a button. Other tones warn you that the headset requires attention, such as when the battery needs recharging, or when you are too far from the base station.

Phone Firmware Release 12.5(1) or later and the defaultheadsetconfig.json file for the Cisco Headset 561 and 562 to function properly with Cisco Unified Communications Manager 12.5(1) or earlier.

Figure 5: Cisco Headset 561



Figure 6: Cisco Headset 562



Cisco Headset 500 Series Support

The Cisco IP Phone 7811 is the only phone in the Cisco IP Phone 7800 Series that does not support a headset. The Cisco IP Phone 7821, 7841, and 7861 use an RJ-style connector to connect with a headset or base.

The Cisco IP Phone 8800 Series has both RJ-style connectors and USB ports to connect to headsets and bases to a phone. But the type of connection depends upon your phone model. The following table describes headset connection and phone model support on the Cisco IP Phone 8800 Series.

Table 1: Headset Support on the Cisco IP Phone 8800 Series.

Cisco Headset 500 Series	Cisco IP Phone 8811 Cisco IP Phone 8841 Cisco IP Phone 8845	Cisco IP Phone 8851 Cisco IP Phone 8851NR Cisco IP Phone 8861 Cisco IP Phone 8865 Cisco IP Phone 8865NR
Cisco Headset 521 Cisco Headset 522	Not Supported	Supported (With USB Inline Controller)
Cisco Headset 531 Cisco Headset 532	Supported (RJ connector)	Supported (RJ connector or with USB Adapter)
Cisco Headset 561 Cisco Headset 562	Supported (Y-cable)	Supported (Y-cable or USB cable)

Cisco Headset 521 and 522 Controller Buttons and Hardware

Your controller buttons are used for basic call features.

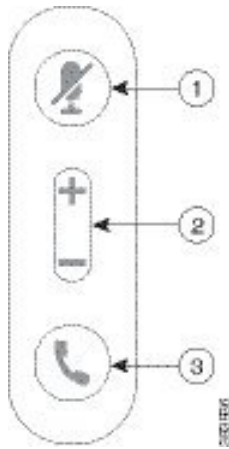
Figure 7: Cisco Headset 521 and 522 Controller

The following table describes the Cisco Headset 521 and 522 controller buttons.

Table 2: Cisco Headset 521 and 522 Controller Buttons

Number	Name	Description
1	Mute button	Toggle the microphone on and off.
2	Volume button	Adjust the volume on your headset.

Number	Name	Description
3	Call	Use to manage calls: <ul style="list-style-type: none"> • Press once to answer an incoming call. • Press and hold to end a call. • Press twice to reject an incoming call. • Press once to put an active call on hold. Press again to retrieve a call from hold. • Press once to put an active call on hold, and to answer an incoming call.

Cisco Headset 531 and 532 USB Adapter Buttons and Hardware

Your adapter is used for basic call features.

Figure 8: Cisco Headset USB Adapter

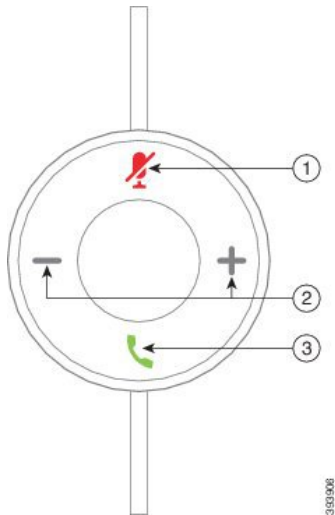

The following table describes the Cisco Headset USB Adapter buttons.

Table 3: Cisco USB Adapter Buttons

Number	Name	Description
1	Mute button	Toggle the microphone on and off.
2	Volume button	Adjust the volume on your headset.

Number	Name	Description
3	Call button	Use to place, answer, and manage your calls: <ul style="list-style-type: none">• Press once to place a call.• Press once to answer an incoming call. Press twice to reject an incoming call.• Press once to put an active call on hold, and to answer an incoming call.• Press once to put an active call on hold.• Press and hold to end a call.

Cisco Headset 561 and 562 Buttons and LED

Your headset buttons are used for basic call features.

Figure 9: Cisco Headset 561 and 562 Headset Buttons

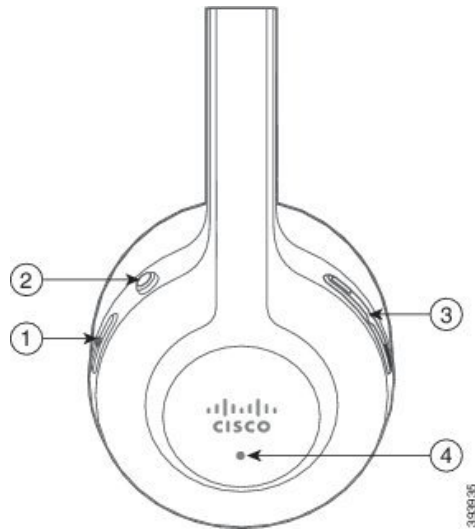

The following table describes the Cisco Headset 561 and 562 Headset buttons.

Table 4: Cisco Headset 561 and 562 Headset Buttons

Number	Name	Description
1	Power and Call button	<p>Use to power the headset on and off.</p> <p>Press and hold for 4 seconds to power on and off the headset.</p> <p>Incoming and active call management depends upon if you have one call or multiple calls.</p> <p>One call:</p> <ul style="list-style-type: none"> • Press once to answer incoming calls. • Press once to put an active call on hold. Press again to retrieve a call from hold. • Press twice to reject an incoming call. • Press and hold to end an active call. <p>Multiple calls:</p> <ul style="list-style-type: none"> • Press once to put an active call on hold, and to answer a second incoming call. • Press once to put a current call on hold. Press again to resume a call, or press and hold for 2 seconds to end the current call and to resume a held call. • Press and hold to end an active call, and to answer another incoming call. • Press twice to stay on a current call, and to reject a second incoming call.
2	Mute button	<p>Toggle the microphone on and off. The Mute  on the phone lights when Mute on the headset is enabled.</p>
3	Volume button	Adjust the volume on your headset.
4	LED	<p>Shows the headset status:</p> <ul style="list-style-type: none"> • Blinking red—Incoming call. • Steady red—Active call. • Blinking white—Firmware upgrade is in progress.

Cisco Headset 560 Series Standard Base

The standard base charges your headset and has LEDs that shows your headset's battery level and call state. You can also answer and end calls when you lift or place your headset on the base.

The standard base comes with the following connector cables:

- USB to USB Cable: for devices with USB connectivity
- USB Y-Cable: for Cisco IP Phones without a USB port
- USB-A to USB-C Cable: available separately for PC or Mac devices.

Figure 10: Standard Base LEDs

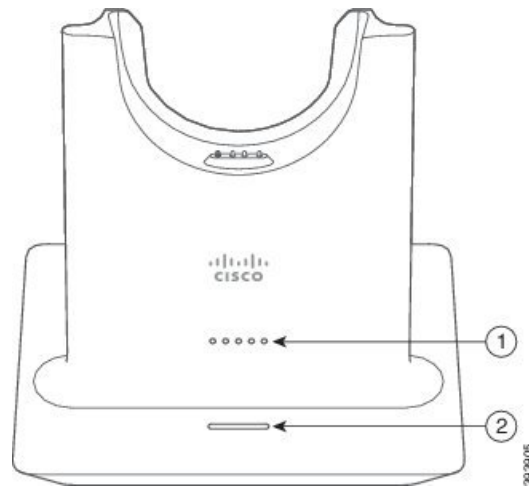

The following table describes the standard base.

Table 5: Standard Base LEDs

Number	Name	Description
1	Battery Status LED	<p>Indicates the headset battery charge and base status:</p> <ul style="list-style-type: none"> • Headset battery strength—LEDs blink and change to solid as the battery charges. • Headset update in progress—LEDs blink in sequence, left to right. • Headset and base not paired—All LEDs blink • Power save mode—Middle LED shows solid. <p>The base enters power save mode when there is no call source connectivity after 10 minutes.</p>

Number	Name	Description
2	Call Status LED	Alerts you to the call state: <ul style="list-style-type: none"> • Incoming call—Blinking green • Active call—Steady green • Muted call—Steady red

Cisco Headset 560 Series Multibase

The multibase can connect up to three call sources through Bluetooth, the USB connector, or the Y-cable. The multibase can save up to four Bluetooth devices. You can switch between call sources using the buttons on the multibase. You use the call control buttons on the headset to answer and end calls. When your headset is in the base, you automatically answer the call when you remove the headset from the base. You can return the headset to the base to end the call.

The multibase comes with the following connector cables:

- USB to USB Cable: for Cisco IP Phones with USB connectivity
- USB Y-Cable: for Cisco IP Phones without a USB port
- Mini USB Cable: for PC or Mac.
- Mini USB to USB-C Cable: available separately for PC or Mac devices.

Figure 11: Multibase LEDs

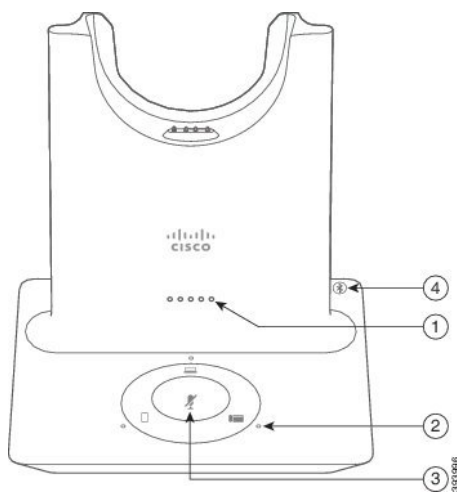

The following table describes the Cisco Headset 560 Series Multibase multibase LEDs.

Table 6: Cisco Headset 560 Series Multibase Multibase LEDs

Number	Name	Description
1	Battery Status LED	<p>Indicates the headset battery charge and base status:</p> <ul style="list-style-type: none"> • Headset battery strength—LEDs blink and change to solid as the battery charges. • Headset update in progress—LEDs blink in sequence, left to right. • Headset and base not paired—All LEDs blink • Power save mode—Middle LED shows solid. <p>The base enters power save mode when there is no call source connectivity after 10 minutes.</p>
2	Call Status LEDs	<p>Alerts you to the call state of each source:</p> <ul style="list-style-type: none"> • Active Source—Steady white • Incoming call on a selected source—Blinks green • Incoming call on an unselected source—Blinks green • Active call on a selected source—Steady green • Active call on an unselected source—Pulses Green
3	Mute Status LED	Alerts you when your headset is muted.
4	Bluetooth Status LED	<p>Alerts you to the Bluetooth status:</p> <ul style="list-style-type: none"> • Paired with a call source—Steady white • Pairing mode—Blinking white • Searching for a call source—Pulse white • Bluetooth is Off—LED is off

You select which call source you want to use with the call source controls on the Multibase. The LED next to each selected source lights up when you select the source.

Even if you are connected to a source, the LED may not be lit. The source LED only lights when the source is selected or has an active call. For example, you may be properly connected to a Cisco IP Phone, your PC, and your mobile phone through Bluetooth. However, the respective source LED is only lit when it is selected, has an active call, or has an incoming call. Press the source button to check if a source is properly connected. The source LED flashes three times if there is no connection.

You can alternate between active call sources.



Note Place an active call on hold before you change to a different call source. Calls on one call source aren't automatically put on hold when you switch to a different call source.

Cisco Headset 700 Series

The Cisco Headset 730 is a wireless headset that uses Bluetooth connectivity to pair with Cisco soft clients and Cisco IP Phones. The headset features full call control and music playback capabilities in addition to powerful noise cancellation and ambient audio enhancement systems for use in a busy office environment.

The Cisco Headset 730 comes with a USB Bluetooth Adapter for use with devices that don't offer a reliable Bluetooth solution. The headset can also connect to devices with the included USB-C to USB-A cable. The USB-C cable also acts as a charging cable and can connect to any powered USB adapter. The USB-C cable can also be plugged into the phone USB port to give full functionality, including call control, local tuning and setup, and firmware upgrades.

For more information see: <https://www.cisco.com/c/en/us/products/collaboration-endpoints/headset-700-series/index.html>

Cisco Headset 730 Buttons and Hardware

Your headset buttons are used for many features. Each cup has different buttons and functions.

Figure 12: Left and Right Sides of the Cisco Headset 730

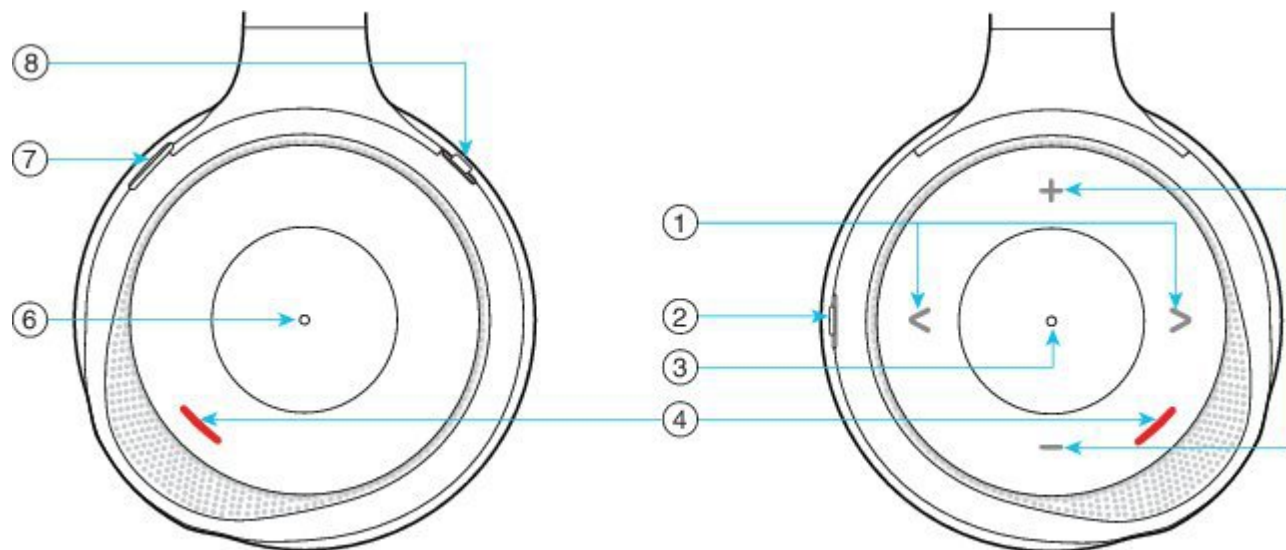









Table 7: Cisco Headset 730 Buttons

Callout Number	Name	Description
1	<p>Skip music track</p> <p>This is the right and left of the right cup face.</p> 	<p>Skip forward and backward through music tracks. Only available if you have the headset paired to a device that can play music.</p>
2	<p>AMB and NC button</p> <p>This button is located on the back of the right cup.</p> 	<p>Three position switch:</p> <ul style="list-style-type: none"> • AMB: Slide to the top to enable ambient mode. • No ambient mode or noise cancellation: Middle position. • NC: Slide to the bottom to enable noise cancellation.
3	<p>Pause and Play</p> <p>This is the center of the right cup and is marked with a dot.</p> 	<p>Press to play or to pause your music. Only available if you have the headset paired to a device that can play music.</p>
4	<p>Presence LED</p> <p>This LED is located on the face of the cup on both the right and left cup.</p> 	<p>Displays red when you are on a call or if you have pressed the Mute button on the headset when you aren't on a call.</p>

Callout Number	Name	Description
5	<p>Volume</p> <p>This is the top and bottom of the right cup face.</p> 	<p>Press the top or bottom to raise or lower the volume.</p>
6	<p>Call button</p> <p>This is the center of the left cup and is marked with a dot.</p>	<p>Controls the call functions, based on the call state:</p> <ul style="list-style-type: none"> • Incoming calls <ul style="list-style-type: none"> • Answer a call: Press once. • Reject a call: Press twice. • Active calls <ul style="list-style-type: none"> • Hold a call: Press once. • End a call: Press and hold until you hear a tone.
7	<p>Mute</p> <p>This is the button on the front of the left cup.</p>	<p>Toggles the microphone on and off.</p> <p>When muted, the Presence LED lights red and the Mute  button on the phone lights.</p>

Callout Number	Name	Description
8	Bluetooth and Power button This is on the back of the left cup. 	Three position switch: <ul style="list-style-type: none"> • Bluetooth: Slide to the top and hold to pair the headset to the phone. • Power: Slide to the middle position to turn the headset on. Slide down to turn the headset off.

Third Party Headsets

Cisco performs internal testing of third-party headsets for use with Cisco IP Phones. But Cisco does not certify or support products from headset or handset vendors. Check with the headset manufacturer to confirm whether you can use it with your Cisco phone.



Note The Cisco IP Phone 7811 does not support a headset.

Headsets connect to your phone using either the USB or the auxiliary port. Depending upon your headset model, you have to adjust your phone's audio settings for the best audio experience, including the headset sidetone setting.

If you have a third party headset, and you apply a new sidetone setting, then wait one minute and reboot the phone so the setting is stored in flash.

The phone reduces some background noise that a headset microphone detects. You can use a noise canceling headset to further reduce the background noise and improve the overall audio quality.

If you are considering a third part headset, we recommend the use of good quality external devices; for example, headsets that are screened against unwanted radio frequency (RF) and audio frequency (AF) signals. Depending on the quality of headsets and their proximity to other devices, such as mobile phones and two-way radios, some audio noise or echo may still occur. Either the remote party or both the remote party and the Cisco IP Phone user may hear an audible hum or buzz. A range of outside sources can cause humming or buzzing sounds; for example, electric lights, electric motors, or large PC monitors.

Sometimes, use of a local power cube or power injector may reduce or eliminate hum.

Environmental and hardware inconsistencies in the locations where Cisco IP Phones are deployed mean that no single headset solution is optimal for all environments.

We recommend that customers test headsets in the intended environment to determine performance before making a purchasing decision to deploy on a large scale.

You can use only one headset at a time. The most-recently connected headset is the active headset.

For a list of suggested headsets and other audio accessories, see http://www.cisco.com/c/en/us/products/unified-communications/uc_endpoints_accessories.html.

Related Topics

[Accessory Support](#)

Audio Quality

Beyond physical, mechanical, and technical performance, the audio portion of a headset must sound good to the user and to the party on the far end. Sound quality is subjective, and we cannot guarantee the performance of any headsets. However, various headsets from leading headset manufacturers are reported to perform well with Cisco IP Phones.

For additional information, see https://www.cisco.com/c/en/us/products/unified-communications/uc_endpoints_accessories.html

Wired Headsets

A wired headset works with all Cisco IP Phone features, including the Volume and Mute buttons. These buttons adjust the earpiece volume and mute the audio from the headset microphone.

When you install a wired headset, make sure you press the cable into the channel in the phone.



Caution

Failure to press the cable into the channel in the phone can lead to cable damage.

Bluetooth Wireless Headsets

Cisco IP Phone 8845, 8851, 8861 and 8865 support Bluetooth. For a list of supported third party headsets, see http://www.cisco.com/c/en/us/products/unified-communications/uc_endpoints_accessories.html.

Bluetooth enables low-bandwidth wireless connections within a range of 66 feet (20 meters). The best performance is in the 3- to 6-foot (1- to 2-meter) range. Bluetooth wireless technology operates in the 2.4 GHz band, which is the same as the 802.11b/g band. Interference issues can occur. We recommend that you:

- Use 802.11a, 802.11n, or 802.11ac that operates in the 5 GHz band.
- Reduce the proximity of other 802.11b/g devices, Bluetooth devices, microwave ovens, and large metal objects.

The Cisco IP Phone uses a shared key authentication and encryption method to connect with headsets. The Cisco IP Phone can connect with up to 50 headsets, one at a time. The last connected headset is used as the default. Pairing is typically performed once for each headset.

After a device is paired, the Bluetooth connection is maintained as long as both devices (phone and headset) are enabled and within range of each other. The connection typically reestablishes itself automatically if either of the devices powers down then powers up. However, some headsets require user action to reestablish the connection.

The Bluetooth icon  indicates that Bluetooth is on, whether a device is connected or not.

Potential interference issues can occur. We recommend that you reduce the proximity of other 802.11b/g devices, Bluetooth devices, microwave ovens, and large metal objects. If possible, configure other 802.11 devices to use the 802.11a channels.

For a Bluetooth wireless headset to work, it does not need to be within direct line-of-sight of the phone. But some barriers such as walls or doors can affect the connection. Interference from other electronic devices can also affect performance.

When headsets are more than 30 feet (10 meters) away from the Cisco IP Phone, Bluetooth drops the connection after a 15- to 20-second timeout. The paired headset reconnects when it comes back into range of the Cisco IP Phone. For certain phone types that operate in power-save modes, you can wake up the headset by tapping on the operational button.

Enable the headset before you add it as a phone accessory.

The phone supports various Handsfree Profile features that allow you to use devices such as Bluetooth wireless headsets for certain tasks. For example, instead of pressing Redial on the phone, you can redial a number from the Bluetooth wireless headset by following instructions from the headset manufacturer.

Cisco IP Phone 8811, 8841, 8851NR, and 8865NR do not support Bluetooth wireless headsets. These hands free features apply to Bluetooth wireless headsets that are used with the Cisco IP Phone 8845, 8851, 8861 and 8865:

- Answer a call
- End a call
- Change the headset volume for a call
- Redial
- Caller ID
- Divert
- Hold and Accept
- Release and Accept

Hands free devices have different feature activation methods. Device manufacturers may also use different terms when referring to the same feature.



Important

Only one headset type works at any given time. If you use both a Bluetooth headset and an analog headset that are attached to the phone, enabling the Bluetooth headset disables the analog headset. To enable the analog headset, disable the Bluetooth headset. Plugging a USB headset into a phone that has Bluetooth headset enabled disables both the Bluetooth and analog headset. If you unplug the USB headset, you can either enable the Bluetooth headset or disable the Bluetooth headset to use the analog headset.

For information about how to use your Bluetooth wireless headset, see:

- *Cisco IP Phone 8800 Series User Guide*
- User Guides provided with your headset

Wireless Headsets

You can use most wireless headsets with your phone. For a list of supported wireless headsets, see http://www.cisco.com/c/en/us/products/unified-communications/uc_endpoints_accessories.html

Refer to your wireless headset documentation for information about connecting the headset and using the features.

Cisco Headset Configuration on Cisco Unified Communications Manager

The Cisco Headset 500 Series and Cisco Headset 730 is supported by most Cisco Unified Communications Manager (Unified CM) releases. But you should install the latest phone firmware release and device packages before connecting your headset to a phone. When the headset is first connected, it will download the required firmware and begin the upgrade process.

The following tables list the Unified CM parameters and the phone firmware release that is required for your Cisco headset to function.

Table 8: Cisco Headset 500 Series Headset Parameters for Cisco IP Phone 7800 Series

Cisco Headset	Phone Firmware	Product Specific Configuration Parameter	Description
Cisco Headset 531 and 532	Phone Firmware Release 12.1(1) or later	Wideband Headset Wideband Headset UI Control	The headset usually requires about 5 seconds to upgrade.
Cisco Headset 561 and 562	Phone Firmware Release 12.5(1)SR1 or later, and the latest device package	Wireless Headset Hookswitch Control Wideband Headset Wideband Headset UI Control	The headset usually requires 5 to 15 minutes to upgrade, and the base LEDs light in sequence to show the upgrade progress. The user can postpone the upgrade up to 4 times. If you are using the Y cable to connect the headset base to the phone, then you must enable Wireless Headset Hookswitch Control.

Table 9: Cisco Headset 500 Series Parameters for Cisco IP Phone 8800 Series

Cisco Headset	Phone Firmware	Product Specific Configuration Parameter	Description and Usage Guidelines
Cisco Headset 521 and 522	Phone Firmware Release 12.1(1) or later	Side USB Port Back USB Port	The headset usually requires about 5 seconds to upgrade.
Cisco Headset 531 and 532	Phone Firmware Release 12.1(1) or later	Side USB Port Back USB Port	The headset usually requires about 5 seconds to upgrade.
Cisco Headset 561 and 562	Phone Firmware Release 12.5(1)SR1 or later, and the latest device package	Wireless Headset Hookswitch Control Side USB Port Back USB Port	The headset usually requires 5 to 15 minutes to upgrade, and the base LEDs light in sequence to show the upgrade progress. The user can postpone the upgrade up to 4 times. If you are using the Y cable to connect the headset base to the phone, then you must enable Wireless Headset Hookswitch Control. If you are using the USB cable to connect the headset base to the phone, then you must the appropriate USB port.

Table 10: Cisco Headset 700 Series Parameters for Cisco IP Phone 8800 Series

Cisco Headset	Phone Firmware	Product Specific Configuration Parameter	Description and Usage Guidelines
Cisco Headset 730	Phone Firmware Release 12.7(1) or later	Side USB Port Back USB Port	The headset usually requires about 5 seconds to upgrade.

Related Topics[Accessory Support](#)

Set Up a Headset for a Single Phone

You can configure a single phone or a group of phones for headset support. To configure a group of phones, use the Common Phone Profile.

Procedure

-
- Step 1** Sign into Cisco Unified Communications Manager Administration as an administrator.
- Step 2** Select **Device > Phone**
- Step 3** Locate the phone associated with the user.

- Step 4** Navigate to the Product Specific Configuration Layout pane and set the fields.
- Step 5** Check the **Override Common Settings** check box for any changed fields.
- Step 6** Click **Save**.
- Step 7** Click **Apply Config**.
- Step 8** Restart the phone.

Headset Parameters on Cisco Unified Communications Manager

The following table describes the fields in the Product Specific Configuration Layout pane that control headset use.

Table 11: Product Specific Configuration Fields for Headsets

Field Name	Field Type or Choices	Default	Description and Usage Guidelines
Disable Speakerphone and Headset	Check box	Unchecked	Turns off the speakerphone and headset capability of the phone.
Disable Handset	Checkbox	Unchecked	Turns off the handset audio path.
Wireless Headset Hookswitch Control	Disabled Enabled	Disabled	<p>Note This parameter is removed from Cisco Unified Communications Manager Software Release 12.5(1)SU2 and later.</p> <p>Enables users to remotely control basic IP phone functionality from the wireless headset. Basic IP phone functionality includes off-hook and on-hook, ring indication, audio volume control, and mute.</p> <p>To use a wireless headset, users connect a base station to the auxiliary port. The base station communicates with the wireless headset.</p>
Wideband Headset	Disabled Enabled	Enabled	<p>Enables or disables the use of a Wideband Headset on the phone. Used in conjunction with User Control Wideband Headset.</p> <p>For more information, see Set Up Wideband Codec, on page 21.</p>
Wideband Headset UI Control	Disabled Enabled	Enabled	Allows the user to use the wideband codec for an analog headset.
Wi-Fi	Disabled Enabled	Enabled	<p>Enables the Cisco IP Phones 8861 and 8865 to connect to the Wi-Fi network.</p> <p>Phones that do not support this feature do not display the field.</p>

Field Name	Field Type or Choices	Default	Description and Usage Guidelines
Side USB Port	Disabled Enabled	Enabled	Controls the ability to use the USB port on the side of the Cisco IP Phones 8851, 8851NR, 8861, 8865, and 8865NR. Phones that do not support this feature do not display the field.
Back USB Port	Disabled Enabled	8861, 8865, and 8865NR: Enabled	Controls the ability to use the USB port on the back of the Cisco IP Phones 8861 and 8865. Phones that do not support this feature do not display the field.
Bluetooth	Disabled Enabled	Enabled	Enables or disables the Bluetooth option on the phone. If disabled, the user cannot enable Bluetooth on the phone. Supported on the Cisco IP Phones 8845, 8851, 8861, and 8865. Phones that do not support this feature do not display the field.
Bluetooth Profiles	Handsfree Human Interface Device	Handsfree	Indicates which Bluetooth profiles on the phone are enabled or disabled.

Set Up Wideband Codec

By default, the G.722 codec is enabled for the Cisco IP Phone. If Cisco Unified Communications Manager is configured to use G.722 and if the far endpoint supports G.722, the call connects using the G.722 codec in place of G.711.

This situation occurs regardless of whether the user has enabled a wideband headset or wideband handset, but if either the headset or handset is enabled, the user may notice greater audio sensitivity during the call. Greater sensitivity means improved audio clarity but also means that the far endpoint can hear more background noise: noise such as rustling papers or nearby conversations. Even without a wideband headset or handset, some users may prefer the additional sensitivity of G.722 distracting. Other users may prefer the additional sensitivity of G.722.

The Advertise G.722 and iSAC Codec service parameter affects whether wideband support exists for all devices that register with this Cisco Unified Communications Manager server or for a specific phone, depending on the Cisco Unified Communications Manager Administration window where the parameter is configured.

Procedure

Step 1

To configure wideband support for all devices:

- a) From Cisco Unified Communications Manager Administration, choose **System > Enterprise Parameters**
- b) Set the Advertise G.722 and iSAC Codec field

The default value of this enterprise parameter is **True**, which means that all Cisco IP Phone Models that register to this Cisco Unified Communications Manager advertise G.722 to Cisco Unified Communications Manager. If each endpoint in the attempted call supports G.722 in the capabilities set, Cisco Unified Communications Manager chooses that codec for the call whenever possible.

Step 2 To configure wideband support for a specific device:

- a) From Cisco Unified Communications Manager Administration, choose **Device > Phone**.
- b) Set the Advertise G.722 and iSAC Codec parameter in the Product Specific Configuration area.

The default value of this product-specific parameter is to use the value that the enterprise parameter specifies. If you want to override this on a per-phone basis, choose **Enabled** or **Disabled**

Headset Management on Older Versions of Cisco Unified Communications Manager

If you have a version of Cisco Unified Communications Manager older than 12.5(1)SU1, you can remotely configure your Cisco headset settings for use with on-premises phones.

Remote headset configuration on Cisco Unified Communication Manager version 10.5(2), 11.0(1), 11.5(1), 12.0(1), and 12.5(1) requires you to download a file from the [Cisco Software Download](#) website, edit the file, and then upload the file on the Cisco Unified Communications Manager TFTP server. The file is a JavaScript Object Notification (JSON) file. The updated headset configuration is applied to the enterprise headsets over a 10 to 30-minute time frame to prevent a traffic backlog on the TFTP server.



Note You can manage and configure headsets through Cisco Unified Communications Manager Administration version 11.5(1)SU7.

Note the following as you work with the JSON file:

- The settings aren't applied if you are missing a bracket or brackets in the code. Use an online tool such as JSON Formatter and check the format.
- Set the **updatedTime** setting to the current epoch time or the configuration is not applied. Alternatively, you can increase the **updatedTime** value by +1 to make it larger than the previous version.
- Do not change the parameter name or the setting will not be applied.

For more information on the TFTP service, see the "Manage Device Firmware" chapter of the *Administration Guide for Cisco Unified Communications Manager and IM and Presence Service*.

Upgrade your phones to the latest firmware release before you apply the `defaultheadsetconfig.json` file. The following table describes the default settings you can adjust with the JSON file.

Download the Default Headset Configuration File

Before configuring the headset parameters remotely, you must download the latest JavaScript Object Notation (JSON) sample file.

Procedure

- Step 1** Go to the following URL: <https://software.cisco.com/download/home/286320550>.
 - Step 2** Choose **Headsets 500 Series**.
 - Step 3** Select your headset series.
 - Step 4** Choose a release folder and select the zip file.
 - Step 5** Click the **Download** or **Add to cart** button, and follow the prompts.
 - Step 6** Unzip the file to a directory on your PC.
-

What to do next

[Modify the Default Headset Configuration File, on page 23](#)

Modify the Default Headset Configuration File

Note the following as you work with the JavaScript Object Notation (JSON) file:

- The settings aren't applied if you are missing a bracket or brackets in the code. Use an online tool such as JSON Formatter and check the format.
- Set the **"updatedTime"** setting to the current epoch time or the configuration is not applied.
- Confirm that **firmwareName** is `LATEST` or the configurations will not be applied.
- Do not change a parameter name or the setting will not be applied.

Procedure

- Step 1** Open the `defaultheadsetconfig.json` file with a text editor.
- Step 2** Edit the **updatedTime** and the headset parameter values you wish to modify.

A sample script is shown below. This script is provided for reference only. Use it as a guide as you configure your headset parameters. Use the JSON file that was included with your firmware load.

```
{
  "headsetConfig": {
    "templateConfiguration": {
      "configTemplateVersion": "1",
      "updatedTime": 1537299896,
      "reportId": 3,
      "modelSpecificSettings": [
        {
          "modelSeries": "530",
          "models": [
            "520",
            "521",
            "522",
            "530",
            "531",
            "532"
          ],
          "modelFirmware": [
```

```

    {
      "firmwareName": "LATEST",
      "latest": true,
      "firmwareParams": [
        {
          "name": "Speaker Volume",
          "access": "Both",
          "usageId": 32,
          "value": 7
        },
        {
          "name": "Microphone Gain",
          "access": "Both",
          "usageId": 33,
          "value": 2
        },
        {
          "name": "Sidetone",
          "access": "Both",
          "usageId": 34,
          "value": 1
        },
        {
          "name": "Equalizer",
          "access": "Both",
          "usageId": 35,
          "value": 3
        }
      ]
    }
  ],
  {
    "modelSeries": "560",
    "models": [
      "560",
      "561",
      "562"
    ],
    "modelFirmware": [
      {
        "firmwareName": "LATEST",
        "latest": true,
        "firmwareParams": [
          {
            "name": "Speaker Volume",
            "access": "Both",
            "usageId": 32,
            "value": 7
          },
          {
            "name": "Microphone Gain",
            "access": "Both",
            "usageId": 33,
            "value": 2
          },
          {
            "name": "Sidetone",
            "access": "Both",
            "usageId": 34,
            "value": 1
          },
          {
            "name": "Equalizer",

```

Step 5 Click **Close**.

Restart the Cisco TFTP Server

After you upload the `defaultheadsetconfig.json` file to the TFTP directory, restart the Cisco TFTP server and reset the phones. After about 10–15 minutes, the download process begins and the new configurations are applied to the headsets. It takes an additional 10 to 30 minutes for the settings to be applied.

Procedure

- Step 1** Log in to Cisco Unified Serviceability and choose **Tools > Control Center - Feature Services**.
- Step 2** From the **Server** drop-down list box, choose the server on which the Cisco TFTP service is running.
- Step 3** Click the radio button that corresponds to the **Cisco TFTP** service.
- Step 4** Click **Restart**.

Connect a Headset to Your Phone

Each type of wired headset, adapter, or base connects to a phone using a different port and a different type of connector and cable. Common types include an RJ connector, a USB connector, and a Y-cable.

Connect a Standard Headset

You can use a standard headset with your desk phone. Standard headsets plug into the headset jack on the back of the phone with an RJ-type connector.

Figure 13: Standard Headset Connection

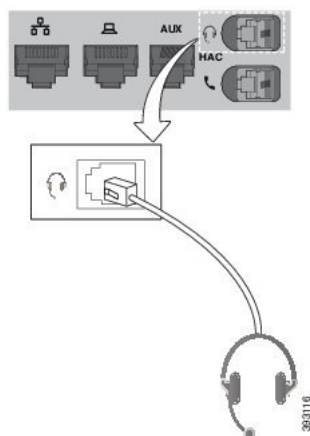

Caution

Failure to press the cable into the channel in the phone can damage the printed circuit board inside the phone. The cable channel reduces the strain on the connector and the printed circuit board.

Procedure

Plug the headset into the headset jack on the back of the phone. Press the cable into the cable channel.

Connect a USB Headset

When you use USB headsets with your phone, keep in mind the following:

- You can use only one headset at a time. The most-recently connected headset is the active headset.
- If you are on an active call and unplug a USB headset, the audio path does not change automatically. Press the **Speakerphone** button or pick up the handset to change the audio.

Your phone may have more than one USB port, depending upon your model. The Cisco IP Phone 8851 and 8851NR has one USB located on the side of the phone. The Cisco IP Phone 8861, 8865, and 8865NR have two USB ports, located on the back and side of the phone.

You may have to remove the plastic cover to access the side USB ports.

Procedure

Plug the USB headset connector into the USB port on the phone.

Connect a Cisco Standard Base with the Y-Cable

You can connect the standard base to your phone with the included Y-cable. But note that the Y-cable has two RJ-type connectors - one for the auxiliary or AUX port, and one for the headset port. You can distinguish between the two connectors by their size, as the AUX port connector is slightly larger than the headset port connector.



Caution Failure to press the cable into the channel in the phone can damage the printed circuit board inside the phone. The cable channel reduces the strain on the connector and the printed circuit board.

Procedure

- Step 1** Plug the smaller connector into the headset jack that is located on the back of the phone. Press the cable into the cable channel.
- Step 2** Plug the larger cable into the AUX port located next to the headset port.
-

Connect the Multibase to a Bluetooth Device

The Cisco Headset 560 Series Multibase can connect to Bluetooth devices such as a mobile phone or tablet. The headset base appears on your call device as **Cisco Headset** followed by the last three digits on your headset serial number.



Note You can find your headset serial number in the lower right corner on the underside of your base.

The multibase can store up to four different paired Bluetooth devices. If you already have four paired devices, the base will replace the device which has not been used in the longest time.

Procedure

Step 1 Press the **Bluetooth** button on the back of the multibase twice to start pairing.

Step 2 Select your headset from the **Settings** menu on your device.

The Bluetooth LED lights white when pairing is successful.

Disconnect the Multibase from a Bluetooth Device

You can disconnect your Multibase from its paired Bluetooth call device.

Procedure

Step 1 Press the **Bluetooth button** on the back of the base once. The LED may take a moment to turn off.

Step 2 Press the **Bluetooth button** again to reconnect to the same call device.

Erase All Bluetooth Pairings

You can erase all saved Bluetooth device pairings.

Procedure

Press and hold the **Bluetooth** button on the back of the multibase for four seconds to clear the memory.

Postpone a Phone Upgrade

When new firmware is available, the New firmware available window is displayed on your phone and a timer begins a 30-second countdown. If you do nothing, the upgrade proceeds.

You can postpone your firmware upgrade for 2 hours and up to 3 times. The upgrade is also postponed if you make or receive a phone call.

Once the upgrade is complete, the headset restarts, and you are prompted to configure your settings.

Procedure

Select **Postpone** to postpone a firmware upgrade.

Cisco Headset Customization

Some Cisco Headset 500 Series are available with a USB adapter that allows you to customize your settings. The headset retains the settings when you switch phones.

You can customize the Cisco Headset 730 headset settings. The headset retains the settings when you switch phones. Currently, you can only customise the settings when you have the headset connected to the phone with the USB-C cable.

You can customize your headset settings if you have one of the following Cisco headsets:

- Cisco Headset 521 and 522
- Cisco Headset 531 and 532
- Cisco Headset 561 and 562
- Cisco Headset 730

Cisco Headset 500 Series Customization

Adjust Your Bass and Treble

You can adjust the bass and treble to customize the headset sound. If you like a headset with a lot of bass, then adjust toward the warm setting. If you prefer more treble, then adjust toward the bright setting.

Procedure

- Step 1** Press **Applications** .
- Step 2** Select **Accessories** and then your headset.
- Step 3** Navigate **Setup > Speaker > Tuning**.

- Step 4** Press the Navigation cluster left, or right, to adjust the tuning.
-

Adjust Your Speaker Sidetone

Sidetone is the term for when you hear your own voice in your headset. Some people find it distracting to hear their own voice during a call, while other people want to know that their headset is working.

Procedure

- Step 1** Press **Applications** .
- Step 2** Select **Accessories** and then your headset.
- Step 3** Navigate **Setup > Speaker > Sidetone**.
- Step 4** Press the Navigation cluster up or down to adjust the sidetone.
- Step 5** Select **Set** to apply your settings.
-

Adjust Your Microphone Volume

Microphone volume is also known as gain, and this setting controls how loud you are to other people on the call.

Procedure

- Step 1** Press **Applications** .
- Step 2** Select **Accessories** and then your headset.
- Step 3** Navigate **Setup > Microphone > Gain**.
- Step 4** Press the Navigation cluster, left or right, to adjust the gain.
-

Cisco Headset 700 Series Customization

Set the Cisco Headset 730 Noise Cancellation Level

Your headset can filter out any background sounds with noise cancellation.

Procedure

- Step 1** Press **Applications** .
- Step 2** Select **Accessories** and then your headset.
- Step 3** Navigate **Setup > Noise cancellation**.

- Step 4** Select the desired setting and press **Set**.
-

Set the Cisco Headset 730 Sidetone Level

Sidetone is the term for when you hear your own voice in your headset. Some people are distracted when they hear their own voice during a call, while other people want to know that their headset is working.

Procedure

- Step 1** Press **Applications** .
- Step 2** Select **Accessories** and then your headset.
- Step 3** Navigate **Setup > Sidetone**.
- Step 4** Select the desired setting and press **Set**.
-

Reset the Cisco Headset 730 Settings

You can reset the headset to the factory default settings.

Procedure

- Step 1** Press **Applications** .
- Step 2** Select **Accessories** and then your headset.
- Step 3** Select **Setup > Reset Settings**.
- Step 4** Press **Reset** to confirm the operation.
-

View the Cisco Headset 730 Details

You can view information about your headset.

Procedure

- Step 1** Press **Applications** .
- Step 2** Select **Accessories** and then your headset.
- Step 3** Press **Show details**.
-

Test Your Microphone

Check your microphone when you first install it, and before you begin a call.

Procedure

- Step 1** Press **Applications** .
 - Step 2** Select **Accessories** and then your headset.
 - Step 3** Navigate to **Setup > Microphone > Test**.
 - Step 4** Press **Record** and speak into the microphone.
 - Step 5** Press **Stop rec** when you finish speaking.
 - Step 6** Press **Play** to review your test recording.
-

Configure a Headset on the Phone

After you have connected the headset, you may have to configure it on your phone.

If you have a Cisco headset with a USB adapter, then follow the steps in [Cisco Headset Customization, on page 29](#)

Reset Cisco Headset Settings from Your Phone

You can reset your Cisco headset to remove your custom settings. This action returns the headset to the original configuration set by your administrator.

Your phone must be running Firmware Release 12.5(1)SR3 or later for this feature to function.

Before you begin

Connect your headset to the phone:

- Cisco Headset 520 Series: Connect with the USB adapter
- Cisco Headset 530 Series: Connect with the USB cable
- Cisco Headset 560 Series: Connect the standard base or multibase with the USB or Y-cable.

Procedure

- Step 1** On the phone, press **Applications** .
 - Step 2** Select **Accessories > Setup > Reset settings**.
 - Step 3** At the warning window, select **Reset**.
-

Adjust the Headset Feedback

When you use a headset, you can hear your own voice in the earpiece, which is called headset sidetone or headset feedback. You can control the amount of headset sidetone on your phone.

Procedure

- Step 1** Press **Applications** .
 - Step 2** Select **Settings** > **Headset sidetone**.
 - Step 3** Select a setting.
-

Turn Bluetooth On or Off

When Bluetooth is active, the Bluetooth icon  appears in the phone screen header.

Procedure

- Step 1** Press **Applications** .
 - Step 2** Select **Bluetooth**.
 - Step 3** Press **On** or **Off**.
-

Add a Bluetooth Headset

Procedure

- Step 1** Make your Bluetooth headset discoverable.
 - Step 2** Press **Applications** .
 - Step 3** Select **Bluetooth** > **Add Bluetooth device**.
Your phone searches for discoverable accessories.
 - Step 4** Select your headset and press **Connect**.
 - Step 5** (Optional) If prompted, enter the PIN for your headset.
-

Disconnect a Bluetooth Headset

You should disconnect your Bluetooth headset before you use it with another device.

Procedure

- Step 1** Press **Applications** .
- Step 2** Select **Bluetooth**.

- Step 3** Select a Bluetooth headset.
 - Step 4** Press **Disconnect**.
-

Remove a Bluetooth Headset

Remove your Bluetooth headset if you aren't going to use it with your phone again.



Procedure

- Step 1** Press **Applications** .
 - Step 2** Select **Bluetooth**.
 - Step 3** Select a Bluetooth headset and press **Delete**.
-

Set Up a Wideband Standard Headset

You can use a headset that supports wideband audio. Wideband audio improves the quality of the sound you hear in the headset.

Procedure

- Step 1** Press **Applications** .
 - Step 2** Select **Accessories > Analog headset > Setup**.
 - Step 3** Press **On** or **Off** to enable or disable wideband for the analog headset.
 - Step 4** Press **Return** .
-

Enable Electronic Hookswitch Control on Your Phone

If your administrator has enabled **Admin settings** on your Cisco IP Phone, you can enable or disable electronic hookswitch control to connect with a Cisco Headset 560 Series base. Electronic hookswitch control is enabled by default.



Note This feature is available on Cisco IP Phone Firmware Release 12.7(1) and later.

Procedure

- Step 1** On your phone, press **Applications** .

- Step 2** Navigate **Admin settings** > **Aux port**.
- Step 3** Select **Connect e-hook headset** to enable electronic hookswitch control.
-

Make a Call with a Standard Headset





Use your headset for hands-free calling that won't disturb your coworker and gives you some privacy.

Procedure



- Step 1** Plug in a headset.
- Step 2** Enter a number using the keypad.
- Step 3** Press **Headset** .
-

Audio Path Selection

When you make or receive a call, the audio path goes to the last device used by you, either the handset, the headset, or the speakerphone. The following list describes each scenario:

- Pick up the handset when you make or answer a call, and all of your calls are routed to your handset until you select **Headset**  or **Speakerphone** .
- Select **Headset**  when you make or answer a call, and all of your calls are routed to your headset until you pick up the handset or select **Speakerphone** .

If your administrator sets your headset as the audio path on your phone, then you can remove the handset and use your headset. This is ideal for anyone who prefers the convenience of a headset. But you must still select **Headset** the first time you handle a call.

- Select **Speakerphone**  when you make or answer a call, and all of your calls are routed to your speakerphone until you pick up the handset or select **Headset** .

Swap Headsets While on a Call

When you connect multiple headsets to the phone, you can switch among the headsets during a call by pressing the **Headset** key on the phone. Though the phone is connected to multiple devices, you see a specific headset is selected as the preferred audio device in the following priority order:

- When you connect only an analog headset to the phone, you make your analog headset the preferred audio device.

Procedure

- Step 1** Before you make or answer a call, press **Headset**.
- Step 2** (Optional) If you place a call, dial the number.
-

Troubleshoot Your Cisco Headset

Try the following basic troubleshooting steps if you have trouble with your Cisco headset.

- Restart your headset.
- Make sure that all cords are properly plugged in and functioning properly.
- Test a different headset with your device to determine if the problem is with your wireless headset or your device.
- Make sure that your phone firmware is the latest release.

Confirm that Your Headset Is Registered

Procedure

Check to see if your headset is registered with the phone.

- Step 1** Press **Applications** 
- Step 2** Navigate to **Accessories**. Select **Show detail**.
-

No Sound in Headset

Problem

There is little or no sound coming through the headset.

Solution

Check the volume level on your headset by pressing the volume controls to adjust the sound level. If the problem continues, use the following work flow to troubleshoot your problem.

Figure 14: No Audio Workflow

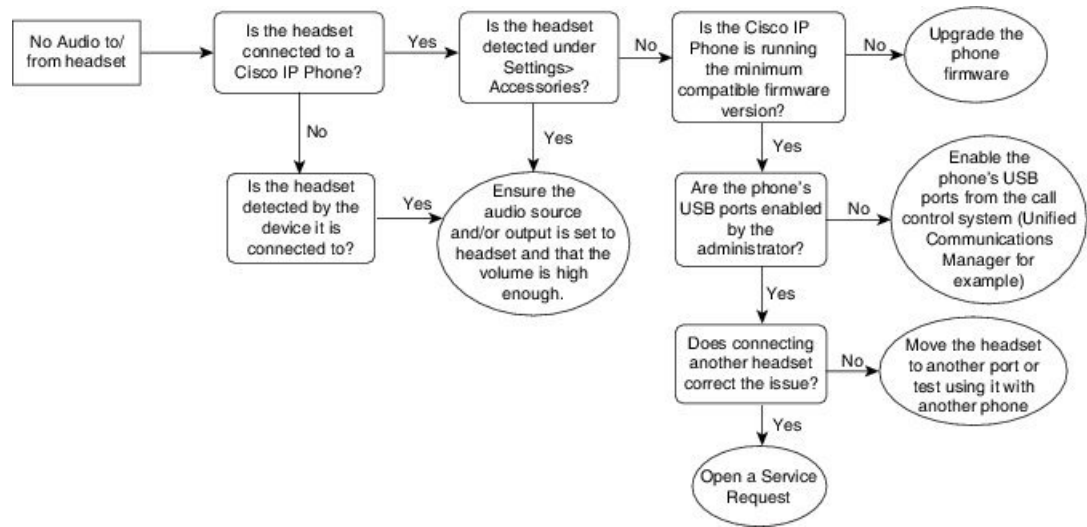

363337

Poor Audio

Problem

Your headset is functioning, but the audio quality is poor.

Solution

Use the following work flow to troubleshoot your problem.

Figure 15: Poor Audio

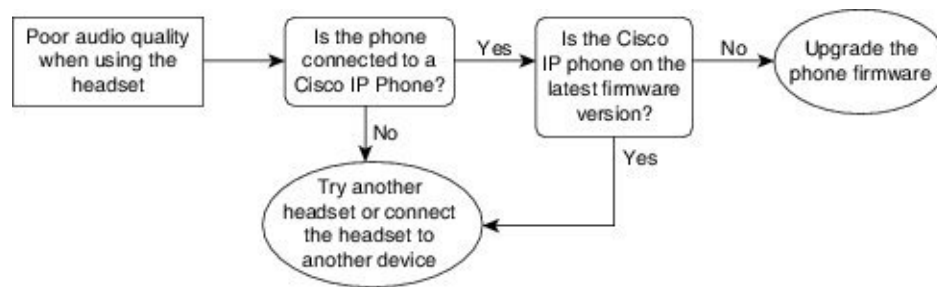

363338

Microphone Not Picking up Sound

Problem

You cannot be heard when using your headset.

Solutions

- Check to make sure your microphone is not muted. Press the mute button on your headset to mute and unmute your microphone.

- Make sure that the microphone boom has been lowered. For optimal sound, keep the headset microphone no further than 1 in or 2.5 cm from your face.
- Make sure that your headset is properly plugged into your device.
- For the Cisco Headset 560 Series, check that you are not taking your headset too far from the headset base. The headset has an effective range of approximately 100 feet or 30 meters.

Headset Not Charging

Problem

Your Cisco Headset 561 and 562 is not charging when placed on the base.

Solution

- Check that your base is plugged into a reliable power source.
- Make sure that your headset is properly seated on the base. When the headset is properly seated, the LED shows solid white. When charging, the LEDs on the base light up in sequence from left to right. When the headset is fully charged, all five battery indicator LEDs show solid white.

Figure 16: Cisco Headset 561 and 562 Headset Placement

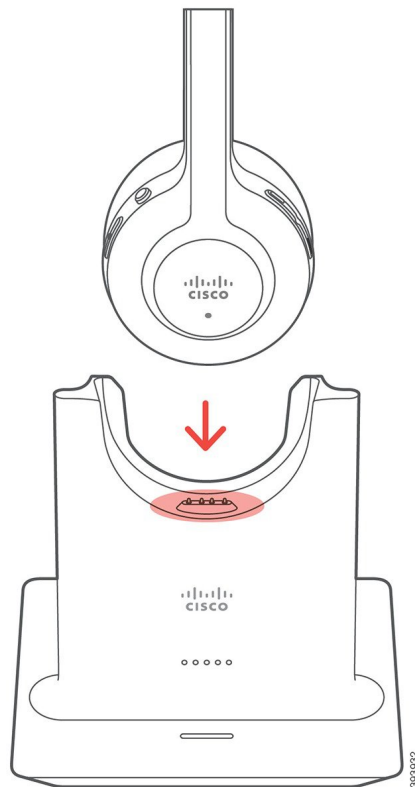

Headset Battery Not Holding a Charge

Problem

The wireless headset is not holding a full charge.

Solution

Your Cisco Headset 561 and 562 holds a charge for up to 8 hours of continuous use. If your headset battery seems weak or defective, contact Cisco support.

